

GAW Report No. 229

# 18th WMO/IAEA Meeting on Carbon Dioxide, Other Greenhouse Gases and Related Tracers Measurement Techniques (GGMT-2015)

(La Jolla, CA, USA, 13-17 September 2015)

WEATHER CLIMATE WATER





GAW Report No. 229

# 18<sup>th</sup> WMO/IAEA Meeting on Carbon Dioxide, Other Greenhouse Gases and Related Measurement Techniques (GGMT-2015)

(La Jolla, CA, USA, 13-17 September 2015)

Edited by Pieter Tans and Christoph Zellweger



WORLD  
METEOROLOGICAL  
ORGANIZATION



GLOBAL  
ATMOSPHERE  
WATCH

THE RECOMMENDATIONS IN THIS REPORT SUPERSEDE THOSE OF  
GAW REPORT No. 213

EDITORIAL NOTE

METEOTERM, the WMO terminology database, may be consulted at:

[http://www.wmo.int/pages/prog/lsp/meteoterm\\_wmo\\_en.html](http://www.wmo.int/pages/prog/lsp/meteoterm_wmo_en.html).

Acronyms may also be found at: [http://www.wmo.int/pages/themes/acronyms/index\\_en.html](http://www.wmo.int/pages/themes/acronyms/index_en.html).

© **World Meteorological Organization, 2016**

The right of publication in print, electronic and any other form and in any language is reserved by WMO. Short extracts from WMO publications may be reproduced without authorization, provided that the complete source is clearly indicated. Editorial correspondence and requests to publish, reproduce or translate this publication in part or in whole should be addressed to:

Chairperson, Publications Board  
World Meteorological Organization (WMO)  
7 bis, avenue de la Paix  
P.O. Box 2300  
CH-1211 Geneva 2, Switzerland

Tel.: +41 (0) 22 730 84 03  
Fax: +41 (0) 22 730 80 40  
E-mail: [publications@wmo.int](mailto:publications@wmo.int)

NOTE

The designations employed in WMO publications and the presentation of material in this publication do not imply the expression of any opinion whatsoever on the part of WMO concerning the legal status of any country, territory, city or area, or of its authorities, or concerning the delimitation of its frontiers or boundaries.

The mention of specific companies or products does not imply that they are endorsed or recommended by WMO in preference to others of a similar nature which are not mentioned or advertised.

The findings, interpretations and conclusions expressed in WMO publications with named authors are those of the authors alone and do not necessarily reflect those of WMO or its Members.

This publication has been issued without formal editing.

## CONTENTS

<b>GROUP PICTURE</b> .....	iii
<b>EXECUTIVE SUMMARY</b> .....	v
<b>SUMMARY OF PURPOSE:</b> <b>WHY WE NEED HIGH ACCURACY ATMOSPHERIC TRACE GAS MEASUREMENTS</b> .....	vii
<b>EXPERT GROUP RECOMMENDATIONS</b> .....	1
<b>1. CALIBRATION OF GAW MEASUREMENTS</b> .....	5
1.1 Background .....	5
1.2 General requirements for Central Calibration Laboratories .....	5
1.3 General requirements for World Calibration Centres .....	7
1.4 Maintenance of calibration by GAW measurement laboratories .....	8
1.5 General recommendations for the quality control of atmospheric trace gas measurements .....	11
1.6 Recommendations for the assessment of new in situ measurement technologies and/or instruments .....	15
<b>2. SPECIFIC REQUIREMENTS FOR CO<sub>2</sub> CALIBRATION</b> .....	18
2.1 Background .....	18
2.2 Current CO <sub>2</sub> calibration and comparison activities.....	18
<b>3. SPECIFIC REQUIREMENTS FOR STABLE ISOTOPE CALIBRATION</b> .....	20
3.1 Background .....	20
3.2 Current calibration and comparison activities of the stable isotopes of CO <sub>2</sub> .....	22
3.3 Recommendations for CO <sub>2</sub> stable isotope calibration and comparison activities....	23
3.4 Isotopic measurements from emerging optical techniques .....	25
3.5 Isotopologues of N <sub>2</sub> O and CO .....	26
3.6 Recommendations for CH <sub>4</sub> isotope calibration and comparison activities .....	26
<b>4. SPECIFIC REQUIREMENTS FOR THE CALIBRATION OF RADIOCARBON IN TRACE GASES</b> .....	27
4.1 Background .....	27
4.2 Current <sup>14</sup> CO <sub>2</sub> calibration and comparison activities .....	28
4.3 Recommendations for <sup>14</sup> CO <sub>2</sub> calibration and comparison activities.....	28
4.4 Calibration and comparison activities for <sup>14</sup> C in other trace gases .....	29
<b>5. SPECIFIC REQUIREMENTS FOR O<sub>2</sub>/N<sub>2</sub> CALIBRATION</b> .....	30
5.1 Background .....	30
5.2 Current O <sub>2</sub> /N <sub>2</sub> calibration and comparison activities .....	31
5.3 Recommendations for O <sub>2</sub> /N <sub>2</sub> calibration and comparison activities .....	32
<b>6. SPECIFIC REQUIREMENTS FOR CH<sub>4</sub> CALIBRATION</b> .....	33
6.1 Background .....	33

6.2	Recommendations for CH <sub>4</sub> calibration and comparison activities .....	33
<b>7.</b>	<b>SPECIFIC REQUIREMENTS FOR N<sub>2</sub>O CALIBRATION</b> .....	<b>34</b>
7.1	Background .....	34
7.2	Recommendations for N <sub>2</sub> O calibration and comparison activities.....	34
<b>8.</b>	<b>SPECIFIC REQUIREMENTS FOR SF<sub>6</sub> CALIBRATION</b> .....	<b>35</b>
8.1	Background .....	35
8.2	Recommendations for SF <sub>6</sub> calibration and comparison activities.....	35
<b>9.</b>	<b>SPECIFIC REQUIREMENTS FOR CO CALIBRATION</b> .....	<b>36</b>
9.1	Background .....	36
9.2	Current CO calibration and comparison activities.....	36
9.3	Recommendations for CO calibration at the WMO/GAW CCL and at GAW stations .....	37
<b>10.</b>	<b>SPECIFIC REQUIREMENTS FOR H<sub>2</sub> CALIBRATION</b> .....	<b>38</b>
10.1	Background .....	38
10.2	Current H <sub>2</sub> calibration and comparison activities.....	38
10.3	Recommendations for H <sub>2</sub> calibration and comparison activities.....	38
<b>11.</b>	<b>RECOMMENDATIONS FOR GREENHOUSE GAS NETWORKS IN AREAS OF HIGH DENSITY EMISSIONS</b> .....	<b>40</b>
<b>12.</b>	<b>RECOMMENDATIONS FOR GROUND-BASED REMOTE SENSING TECHNIQUES</b> .....	<b>41</b>
<b>13.</b>	<b>RECOMMENDATIONS FOR AIR MEASUREMENTS OF CO<sub>2</sub> ON SHIPS</b> .....	<b>42</b>
13.1	Background .....	42
13.2	Recommendations .....	42
<b>14.</b>	<b>RECOMMENDATIONS FOR DATA MANAGEMENT, ARCHIVING, AND DISTRIBUTION</b> .....	<b>44</b>
14.1	Data management .....	44
14.2	Data archiving.....	44
14.3	Co-operative data products .....	46
14.4	Data distribution.....	47
<b>15.</b>	<b>RECOMMENDATIONS FOR THE COOPERATIVE WMO/GAW NETWORK</b> .....	<b>48</b>
<b>16.</b>	<b>THE ORGANIZATION OF GGMT-2017</b> .....	<b>51</b>
	<b>References</b> .....	<b>52</b>
	Annex I - List of participants .....	57
	Annex II - Meeting agenda.....	60
	Annex III - Poster sessions.....	65
	Annex IV - Workshop proceedings .....	71



**Participants attending the 18<sup>th</sup> WMO/IAEA Meeting on Carbon Dioxide,  
Other Greenhouse Gases and Related Measurement Techniques (GGMT-2015)  
in La Jolla, CA, USA, 13-17 September 2015**

(<http://ggmt-2015.com/>)





## EXECUTIVE SUMMARY

Understanding the global carbon cycle and role of greenhouse gases for climate change to be able to take balanced and scientifically founded actions on emissions control requires well-established integrated global greenhouse gas observing systems. The Global Atmosphere Watch (GAW) Programme of the World Meteorological Organization (WMO) provides a framework for the development and implementation of integrated greenhouse gas (GHG) observations. Measurements of greenhouse gases come from flask sampling and continuous measurement sites, while aircraft, satellite and ground-based remote sensing observations provide vertical components of observations integrated into the global fields via modelling. As part of this GHG programme, WMO organizes biennially with the International Atomic Energy Agency (IAEA) a meeting to review the scientific understanding of greenhouse gas sources and sinks, to evaluate the network development, to review the best practices for quality assurance and quality control, and to examine data quality objectives and measurement techniques.

The 18th WMO/IAEA Meeting on Carbon Dioxide, Other Greenhouse Gases, and Related Measurement Techniques (GGMT-2015) took place from 13 to 17 September 2015 at the Scripps Institution of Oceanography in La Jolla (CA), USA. It was the 40<sup>th</sup> anniversary of the first GGMT meeting (then called "CO<sub>2</sub> Experts Meeting") which was also held at Scripps in 1974. WMO has provided the framework for all carbon dioxide experts meetings since 1975. IAEA in Vienna joined WMO as a co-organizer in 1997 due to the increased use of carbon isotopes in studying the carbon cycle.

The meeting reviewed current WMO data quality objectives and observation scales, covering such topics as carbon dioxide and other greenhouse gases, stable isotopes, radiocarbon in greenhouse gas measurements, calibration, quality control, data management and archiving. The workshop also discussed new and emerging technologies, including measurements of greenhouse gases with high-precision spectroscopic methods. Special goals for GGMT-2015 were to have a larger emphasis on carbon monoxide measurements and to expand the scope to include measurements of dissolved greenhouse gases and related ocean tracers and to discuss GHG observations in the urban environment.

The group made an update of the recommendations on the WMO data quality objectives, calibration, and data management as well as on the development of the GAW Programme in general. To reach these challenging objectives, we have to be compatible with ISO requirements for testing and calibration laboratories, implement a Quality Management System (QMS), and also apply modern metrological concepts on calibrations and measurements including the uncertainty propagation.

These recommendations are summarized in the first part of the meeting report. A number of reports presented at the meeting are included in Annex IV.



## **SUMMARY OF PURPOSE: WHY WE NEED HIGH ACCURACY ATMOSPHERIC GREENHOUSE GAS MEASUREMENTS**

The United Nations Framework Convention on Climate Change (UNFCCC), which has been signed by nearly all nations, requires signatories to assess greenhouse gas emissions. The requirement has become more urgent after the Conference of the Parties (COP21) agreement signed in December 2015. The Paris Agreement in Article 7 calls for “strengthening scientific knowledge on climate, including research, systematic observation of the climate system and early warning systems, in a manner that informs climate services and supports decision-making”.

Three main objectives justify atmospheric observations:

1. To monitor atmospheric greenhouse gas burdens because the increases force climate change, and there could be surprises as the natural systems respond to increasing CO<sub>2</sub>, a changing climate, and human management.
2. To quantify natural and anthropogenic emissions and removals of greenhouse gases (GHG), including attribution by region and by process, and to understand the controlling processes.
3. To provide tools for the improvement of the self-reported “bottom-up” UNFCCC emission inventories using “top-down” estimates based on atmospheric observations and models.

The changing global burden can be quantified most accurately and effectively by making well-calibrated in situ measurements and by collecting air samples at carefully chosen “baseline” (or “background”) sites. These are places with access to air that can represent large areas and where short-term variability due to nearby emissions/removals (also called sources/sinks) is minimal.

Objectives 2 and 3 require a combination of high precision measurements, which includes both in situ instrumentation and flask samples at background locations with and without intermittent influence from sources/sinks but also at locations with regional and local representativeness, as well as remote sensing from the ground and perhaps also from satellite platforms.

Long-term, high-quality in situ observations at the surface, on tall towers, aircraft, and balloons, are indispensable for reliable detection and quantification of long-term changes in GHG emissions and sinks. Modelling studies using these in situ measurements provide local, regional and global assessment of atmospheric emissions and removals by season, source type and location. These studies are further strengthened by remote sensing estimates of the total column by ground-based spectrometers that measure absorption of solar radiation by specific gases. However, these complementing remote sensing GHG measurements also rely on high-quality, traceable and calibrated in situ measurements because a direct calibration of those

measurements is not possible. This is due to the fact that one cannot control the sample in the optical path, nor potential interferences. It has been shown, e.g. by Karion et al. (2010), that the TCCON (Total Carbon Column Observing Network) measurements should be regularly validated with calibrated in situ measurements on aircraft of the partial column and with balloon launched AirCore flights, which collect a vertically resolved in situ sample, also measured on calibrated instruments, through  $\sim 99\%$  of the total column. TCCON plays a crucial role in the validation of satellite-based remote sensing studies that are as yet developmental and of low precision, lack long-term continuity, and are subject to a number of biases, some known and probably several as yet unknown. They do not cover with sufficient accuracy the full suite of GHG and associated tracers defined by the World Meteorological Organization's Global Atmosphere Watch Programme (WMO/GAW), but they offer the prospect of dense global measurements, which could greatly help global understanding.

A major limiting factor of all studies that infer sources/sinks from observed mole fractions of greenhouse gases are the atmospheric transport models. They not only need to describe the winds correctly, but also there are often serious shortcomings of mixing processes between the boundary layer and the free troposphere, of convective events, of mixing between the hemispheres, of flow over complex terrain, to name a few. Improvements need to come from outside our community but we have to state it as an urgent need. This does not negate our requirements for making the best possible greenhouse gas measurements in today's world. We do not get another chance to do so, whereas models are being retroactively improved.

The scientific priorities for GHG study in WMO/GAW are thus to sustain and enhance the global in situ measurement network, and simultaneously use the network to improve and ground-truth developing satellite products/retrievals (in collaboration with TCCON) by allowing ongoing diagnosis and elimination of biases in the measurements and retrieval algorithms. In fact, without a considerable expansion of the GAW network this task will be nearly impossible after the largest biases ( $\sim 1$  ppm or larger for  $\text{CO}_2$ ) have been addressed, while sub-ppm biases are very likely to still cause large errors in inferred emissions for individual nations and regions. To illustrate this point, a simple mass balance for typical meteorological conditions shows that a 1 GtonC/year carbon source in the U.S. causes the full column-integrated  $\text{CO}_2$  mole fraction to increase by only  $\sim 0.5$  ppm on average. If we want to use atmospheric soundings to determine such a source magnitude to 20% uncertainty, a column-average measurement precision, after averaging over an appropriate number of samples, of  $\sim 0.1$  ppm is required. Stated differently, space and time dependent biases need to be eliminated to a relative precision of one part in 4000 in ambient atmospheric  $\text{CO}_2$ . This is more demanding than any trace gas measurement ever performed from space by more than a factor of ten. Similar requirements apply to other long-lived greenhouse gases, such as methane and nitrous oxide.

All calibrated and quality-controlled results can then be integrated into local, regional and global data assimilation systems. Models have their own biases, and a comprehensive set of calibrated measurements will also be needed to diagnose and minimize such biases. On the global scale the systematic observations of GHG concentrations in the atmosphere and oceans and linked process-oriented carbon cycle observations will improve our understanding of the workings of the carbon cycle and how it responds to climate change, possibly as a positive

feedback to climate forcing. On regional and urban scales, the results will provide an independent assessment of GHG emissions and trends as needed by the public and by policymakers.

Two major regional programmes are acting to improve atmospheric trace gas observations in GAW in North America (North American Carbon Programme, NACP: <http://www.nacarbon.org/nacp/>) and Europe (Integrated Carbon Observation System, ICOS: <http://icos-infrastructure.eu>). Several laboratories in Japan operate a large programme of measurements on aircraft and ships, and at surface sites. It is important that these and similar regional programmes remain tightly linked to the international WMO/GAW effort and produce regional data sets that can be merged safely into an enhanced global picture of GHG budgets. Building expertise in developing countries including the establishment of high-quality measurement capabilities remains a critical issue for achieving adequate spatial coverage of the globe in the coming decade. WMO and IAEA can make large contributions here through training courses, and stimulating partnerships between laboratories.

Solid and trusted facts are indispensable to successful international treaties, national policies, and regional strategies for emission reductions, efficiency improvements, and emissions offsets. Independent, transparent, globally coherent information is essential. The closest thing the world has to a globally consistent greenhouse gas observation network is the WMO's Global Atmosphere Watch Programme. However, providing coherent, regional-scale information requires not only enhanced observations, but also improved modelling and ensemble reanalysis. WMO/GAW needs both to sustain the high-quality programme of open-access atmospheric observation, and to encourage multiple independent modelling studies to analyse the measurements.

---



## EXPERT GROUP RECOMMENDATIONS

### EXPERT GROUP RECOMMENDATIONS FOR MEASUREMENTS OF CARBON DIOXIDE, OTHER GREENHOUSE GASES, AND RELATED MEASUREMENT TECHNIQUES

The scientists present at the 18<sup>th</sup> WMO/IAEA Meeting of Experts on Carbon Dioxide, Other Greenhouse Gases and Related Tracers Measurement Techniques (abbreviated as GGMT-2015), 13-17 September 2015, in La Jolla, CA, USA, recommend the following procedures and actions, to achieve the adopted WMO goals for GAW network compatibility among laboratories and central facilities as summarised in Table 1. These goals are motivated from the perspective of the required data quality and compatibility for interpretation of global or continental scale atmospheric data, obtained from different laboratories, and for joint use in atmospheric transport model inversion studies in particular in support of the objectives formulated in the introduction. These compatibility goals should be reached in the respective specified mole fraction ranges observed in the global background troposphere.

The use of terminology has to be based on standardized definitions as released by ISO Guides (International Organization for Standardization; [www.iso.org](http://www.iso.org)), in particular the Joint Committee for Guides in Metrology (JCGM) (for details see: <http://www.iso.org/sites/JCGM/JCGM-introduction.htm>), and has been requested by GAW since WMO/GAW Report No. 142 (2001), "Strategy for the Implementation of the Global Atmosphere Watch Programme (2001–2007)" and highlighted further in the WMO/GAW Strategic Plan: 2008-2015 (WMO/GAW Report No. 172) and its Addendum (WMO/GAW Report No. 197) and the GAW Implementation Plan 2016 - 2023 (WMO/GAW Report No. 228).

Currently, some of the terms related to measurements as well as to Quality Assurance & Quality Control (QA/QC) in atmospheric science are used with different meanings and/or on the basis of different definitions. Since WMO and IAEA are signatories to the International Committee for Weights and Measures (CIPM) Mutual Recognition Arrangement (MRA) (<http://www.bipm.org/en/cipm-mra/>) the use of accepted terminology within GAW has become even more important. Definitions of terms concerning recommended ISO terminology are given in the 3rd edition of the International Vocabulary of Metrology (VIM) (<http://www.bipm.org/en/publications/guides/vim.html>). The reader is also referred to the ISO publication "Guide to the Expression of Uncertainty in Measurement" (GUM, 2008, and at <http://www.bipm.org/en/publications/guides/gum.html>). More explanations, particularly with respect to the transition from VIM2 to VIM3, are given in De Bièvre (2008). All GAW participants are strongly encouraged to take note of the ISO documents and consult the GAW glossary on Quality Assurance and Quality Control terms at <http://www.empa.ch/gaw/glossary>, which provides a summary of the most relevant terms for WMO/GAW.

"Comparability" means that results (of different labs) are comparable i.e. can be compared. In a metrological sense this simply means that results have to be on the same scale to be compared. By consistent use of the same scale for the same compound (in all steps such as

measurements, determination of corrections etc.), one will have comparability of results. "Compatibility", a property of a set of measurement results, means that results are compatible, within a specified numerical value. Metrologically this means (an oversimplification): the absolute value of the difference between any pair of measured values from two different measurement results is within a chosen value which does not have to be the same as the total combined uncertainty. For instance, the total combined uncertainty in two labs might be  $\pm 0.1$  per mil (for example) and still results can be compatible within 0.01 per mil.

This document defines the conventional reference scale for a trace gas-in-dry-air as the reference for mole fraction measurements of that gas. It is embodied in a unique set of primary measurement standards with values assigned and linked to SI by primary reference measurement procedures. The scale is propagated over a defined mole fraction range to secondary measurement standards. The conventional reference scale is maintained over many years through primary reference measurement procedures at regular intervals, with a focus on long-term consistency, and may involve value reassignment (e.g. if primary measurement standards are found to be changing with time).

**The following definitions and units are used throughout this document:**

Mole fractions of substances in dry air (dry air includes ALL gaseous species except water):

**ppm** = mmol/mol =  $10^{-6}$  mole of trace substance per mole of dry air

**ppb** = nmol/mol =  $10^{-9}$  mole of trace substance per mole of dry air

**ppt** = pmol/mol =  $10^{-12}$  mole of trace substance per mole of dry air

The organizations participating in WMO/GAW agree that they will only use the above notation (that is, nmol/mol or ppb, etc.) in their data distribution and scientific publications, thus discontinuing the use of ambiguous terms such as ppmv, ppbv, and pptv. In communicating with the general public it is advisable to continue using the term "concentration" instead of "mole fraction" because the latter is an unknown term for most people.

Isotopic ratio measurement results are expressed as deviations from an agreed-upon international reference measurement standard (which defines corresponding isotope scales) using the delta notation:

$$\delta = (R_{\text{sample}}/R_{\text{reference}} - 1), \text{ with } R = [\text{rare isotope}]/[\text{abundant isotope}].$$

$\delta$ -Values are expressed in multiples of 0.001 (‰; per mil 'units').

The international scale for  $\delta^{13}\text{C}$  is VPDB (Vienna Pee Dee Belemnite). NBS 19 calcite is the primary international reference material used for the realisation of the VPDB scale, whereas LSVEC lithium carbonate is intended to be used for 2-point data normalisation. NBS 19 has an accepted  $\delta^{13}\text{C}$  value of +1.95‰ on the VPDB scale origin. LSVEC has  $\delta^{13}\text{C} = -46.6\text{‰}$  on the VPDB scale. All reported  $\delta^{13}\text{C}$  data, including air- $\text{CO}_2$  isotopic values, are to be 2-point normalized, by using NBS 19 – LSVEC directly or to other two reference materials being traceable to NBS 19 – LSVEC (Coplen et al., 2006).



For  $\delta^{18}\text{O}$ , multiple scales are in use (VPDB, Vienna Standard Mean Ocean Water (VSMOW), air- $\text{O}_2$ ). For  $\text{CO}_2$  in air samples, the common scale is the VPDB- $\text{CO}_2$  scale (Brand et al., 2010), which is realised through NBS 19 by carbonate- $\text{H}_3\text{PO}_4$  digestion under controlled conditions. Thus, standardisation of the carbonate- $\text{H}_3\text{PO}_4$  digestion reaction is of highest importance (Wendeberg et al., 2011). Although the VPDB- $\text{CO}_2$  scale is linked to the VSMOW scale, the 2-point VSMOW-SLAP data normalisation cannot be applied to air- $\text{CO}_2$   $\delta^{18}\text{O}$  data for practical reasons.

For all hydrogen isotope measurement results (e.g. on air methane), the common scale is the VSMOW scale, which includes the 2-point VSMOW2-SLAP2 data normalisation.

R abundance variations of  $\text{O}_2/\text{N}_2$  (and  $\text{Ar}/\text{N}_2$ ) ratios in air are also expressed as delta notation:

$$\delta (\text{O}_2/\text{N}_2) = (\text{R}_{\text{sample}}/\text{R}_{\text{standard}} - 1) \text{ with } \text{R} = \text{O}_2/\text{N}_2 \text{ (see Section 5)}$$

$\delta (\text{O}_2/\text{N}_2)$  values are expressed in multiples of  $10^{-6}$  or per meg 'units'.

The respective international air standard is not established, yet. The Scripps Institution of Oceanography (SIO) local  $\text{O}_2/\text{N}_2$  scale, based on a set of cylinders filled at the Scripps Pier is the most widely used measurement standard.

**Table 1. Recommended compatibility of measurements within the scope of GGMT**

<i>Component</i>	<i>Compatibility goal 1-sigma</i>	<i>Extended compatibility goal<sup>1</sup></i>	<i>Range in unpolluted troposphere (approx. range for 2015)</i>	<i>Range covered by the WMO scale</i>
$\text{CO}_2$	$\pm 0.1$ ppm (North.Hem.) $\pm 0.05$ ppm (So.Hemisph)	$\pm 0.2$ ppm	380 - 450 ppm	250 - 520 ppm
$\text{CH}_4$	$\pm 2$ ppb	$\pm 5$ ppb	1750 - 2100 ppb	300 - 5900 ppb
$\text{CO}$	$\pm 2$ ppb	$\pm 5$ ppb	30 - 300 ppb	30 - 500 ppb
$\text{N}_2\text{O}$	$\pm 0.1$ ppb	$\pm 0.3$ ppb	325 - 335 ppb	260 - 370 ppb
$\text{SF}_6$	$\pm 0.02$ ppt	$\pm 0.05$ ppt	8 - 10 ppt	2.0 - 20 ppt
$\text{H}_2$	$\pm 2$ ppb	$\pm 5$ ppb	400 - 600 ppb	140 - 1200 ppb
$\delta^{13}\text{C}-\text{CO}_2$	$\pm 0.01$ ‰	$\pm 0.1$ ‰	-9.5 to -7.5‰ (VPDB)	
$\delta^{18}\text{O}-\text{CO}_2$	$\pm 0.05$ ‰	$\pm 0.1$ ‰	-2 to +2‰ (VPDB- $\text{CO}_2$ )	
$\Delta^{14}\text{C}-\text{CO}_2$	$\pm 0.5$ ‰	$\pm 3$ ‰	-50 to 50‰	
$\Delta^{14}\text{C}-\text{CH}_4$	$\pm 0.5$ ‰		50-350‰	
$\Delta^{14}\text{C}-\text{CO}$	$\pm 2$ molecules $\text{cm}^{-3}$		0-25 molecules $\text{cm}^{-3}$	
$\delta^{13}\text{C}-\text{CH}_4$	$\pm 0.02$ ‰	$\pm 0.2$ ‰		
$\delta \text{D}-\text{CH}_4$	$\pm 1$ ‰	$\pm 5$ ‰		
$\text{O}_2/\text{N}_2$	$\pm 2$ per meg	$\pm 10$ per meg	-900 to -400 per meg (vs. SIO scale)	

<sup>1</sup> See text for further details/explanation

Values given in Table 1, column 2, are the scientifically desirable level of compatibility for measurements of well-mixed background air. They may not be the currently achievable best measurement uncertainty (1 sigma) for individual analyses of most species. However, these compatibility goals need to be targeted for application areas which require the highest possible compatibility among different data sets or data providers, such as for the detection of global trends, research related to climate change or the compliance with international conventions and treaties. An extended compatibility goal is provided as a guideline for many other studies in which the highest precision and accuracy is not required, for example a regionally focused study with large local fluxes, or services related to urban air quality.

There is no international WMO/GAW Central Calibration Laboratory for O<sub>2</sub>/N<sub>2</sub> measurements. Current international comparisons of O<sub>2</sub>/N<sub>2</sub> indicate that the compatibility between any two laboratories is not better than  $\pm 5$  per meg. For  $\Delta^{14}\text{CO}_2$  analyses there is little experience with long-term compatibility of different laboratories, but for global as well as regional applications the desired reproducibility of individual measurements should be better than  $\pm 3\text{‰}$ .

---

## 1. CALIBRATION OF GAW MEASUREMENTS

### 1.1 Background

Round-robin comparisons of laboratory standards and comparisons of field measurements and samples over the last decades have regularly shown differences in trace gas measurements larger than the target compatibility for merging data from different field sites (see Table 1). These systematic differences contribute to uncertainties in the location and magnitude of surface fluxes derived from atmospheric composition measurements. The WMO/GAW Central Calibration Laboratories (CCL) for important greenhouse and trace gases therefore remain one of the fundamental components of the WMO/GAW Programme (WMO/GAW Reports No. 172 and 197 and the GAW Implementation Plan for the period 2016-2023 available on the GAW web page) to achieve and maintain compatibility of global observations from different laboratories.

WMO/GAW CCLs currently exist for: carbon dioxide (CO<sub>2</sub>, at the National Oceanic and Atmospheric Administration/Earth System Research Laboratory (NOAA/ESRL)), methane (CH<sub>4</sub>, at NOAA/ESRL), nitrous oxide (N<sub>2</sub>O, at NOAA/ESRL), carbon monoxide (CO, at NOAA/ESRL), sulphur hexafluoride (SF<sub>6</sub>, at NOAA/ESRL), stable isotopes in CO<sub>2</sub> (only for CO<sub>2</sub>-in-air measurements, at Max-Planck Institute for Biogeochemistry (MPI-BGC)), and hydrogen (H<sub>2</sub>, at MPI-BGC).

In this section, the general requirements for WMO/GAW CCLs and general issues to maintain calibration of observations by GAW laboratories are discussed. Additional trace gas-specific needs are dealt with separately in subsequent sections.

### 1.2 General requirements for Central Calibration Laboratories

- a) The WMO Mole Fraction Scale for each species is embodied in an adequate set of gas mixtures-in-dry-air in high-pressure cylinders (called "WMO Primary Standards") spanning the range of interest to the WMO community. The CCLs maintain the link of each scale to fundamental quantities (SI) by carrying out regular determinations of each cylinder using primary reference measurement procedures or through other suitable techniques, such as regular comparisons with new sets of gravimetric mixtures or with dilutions from stable mixtures with high mole fraction of the species of interest. Isotopic ratios should be reported on the existing accepted scales, such as VPDB, VSMOW. In this case the CCL maintains a common "Scale Anchor" to the accepted scales, in order to achieve more stringent compatibility between laboratories.
- b) The CCL carries out comparisons with independent primary scales, established either through gravimetric, manometric, or other means. For the stable isotope scale of CO<sub>2</sub> in air, the CCL establishes the link to the respective international stable isotope scales (e.g. VPDB for  $\delta^{13}\text{C}$ ).

- c) The WMO scale for each trace gas is defined and maintained by an operational, designated CCL. WMO and IAEA strive for all monitoring systems to be formally traceable to Primary Reference Materials or Fundamental Constants (SI) through National Metrology Institutes (NMI) and the International Bureau of Weights and Measures (BIPM). This is an essential pre-requisite for an internationally recognized and homogeneous monitoring system of in situ chemical measurements and as such is a primary responsibility of the CCL's.
- d) CCL's should develop and maintain a Quality Management System (QMS) for their calibration and measurement capabilities which meets the requirements of ISO 17025, and possibly ISO Guide 34, to the extent possible. NOAA can share expertise with the other CCLs on the steps required to establish a QMS.
- e) The CCL should participate in Key Comparisons of the Consultative Committee for Amount of Substance – Metrology in Chemistry (CCQM) if it is entitled to do so. When a CCL without a mandate to participate in CCQM activities wants to participate in Key Comparisons, it should request WMO for a signature of the side letter to the official WMO- CIPM agreement.
- f) This Expert Group and the GAW Scientific Advisory Group (SAG) on GHG undertake the responsibility for the evaluation of the effectiveness of CCL procedures and for recommending modifications to existing protocols.
- g) The CCL will update its scale when warranted, as the gas mole fractions of the WMO Primary Standards may become better known over time through repeated primary reference measurement procedures and comparisons. Revisions of the WMO Scale by the WMO/GAW CCL must be distinguished by name, such as WMO CO<sub>2</sub> X2007, and the appropriate version number should be included in each standard calibration report. The CCL archives all earlier versions of the WMO scale.
- h) The current scales are (as of June 2016):

WMO CO<sub>2</sub> X2007  
WMO CH<sub>4</sub> X2004A  
WMO CO X2014A  
WMO N<sub>2</sub>O X2006A  
WMO SF<sub>6</sub> X2014  
WMO H<sub>2</sub> X2009

The "X" stands for mole fraction.

Names for isotopic scale anchors could be, for example, WMO isoCO<sub>2</sub> 2012, etc.

- i) The CCL provides complete and prompt disclosure of all relevant data pertaining to the maintenance and transfer of the primary scale, such as manometric calibration procedures and results, and an estimate of the expected uncertainty introduced by the calibration transfer procedure to each individual standard. The CCL maintains a record of traceability of each standard to the Primary scale, which could include intermediate secondary standards.
- j) The CCL provides calibrated reference gas mixtures (gas mixtures-in-dried-natural air, called "transfer standards") at the lowest possible cost and maintains or

develops the ability to address changing demand in calibration mixtures, including those characterised in CO<sub>2</sub> stable isotope composition.

- k) In view of different specific sensitivities of various instrumentation to the isotopic composition of the analytes, the isotopic composition of the analyte (CO<sub>2</sub>, CH<sub>4</sub>, N<sub>2</sub>O, others) in transfer standards should be close to atmospheric levels. If the preparation of the standard gas involves the addition of the analyte, the CCL provides information on the isotopic composition of the addition and the approximate fraction of this admixture to the total analyte in air, or provides measured isotopic ratio values for the main isotopologues of the standard ("information values") if the potential impact of anomalous values requires it.
- l) The CCL provides for a backup to the embodiment of the primary scale (e.g. a suite of calibrated Primary or Secondary cylinders) in case a catastrophic event occurs.
- m) The CCL, or a designated WMO/GAW World Calibration Centre (a list of current central facilities is available in the GAW Implementation Plan for the period 2016-2023 (GAW Report No. 228), accessible on the WMO/GAW web page), organizes round-robin comparisons of laboratory calibrations by distributing sets of high-pressure cylinders to be measured by participating laboratories. The round-robin comparisons are to be used for an assessment of how well the laboratories are maintaining their link to the WMO Mole Fraction Scale, or to a WMO Scale Anchor for isotopic ratios. They are not to be used for re-defining laboratory calibration scales, because that would effectively establish two or more traceable paths to the primary scale instead of a single hierarchical path. It is recommended that round-robins are repeated once every two years. However, experience shows that comparisons of reference gases by themselves are not sufficient to ensure that atmospheric measurements are compatible to the degree that is required.
- n) To maximize the usefulness of round-robin results, every participating laboratory has to complete its analyses within two to four weeks (depending on the number of species measured) and then to immediately send the cylinders to the next participant. The circulation of the cylinders is discontinued after two years at the latest, and results are evaluated even if all labs were not able to analyse the tanks. A new round-robin will then be started with the labs that had not been included to be first in line. Tracking tank circulation and data submission will be rigorous with the status of tank circulation and data submission being posted online on a web page maintained by the laboratory organizing the round-robin. Analysis of CO<sub>2</sub> mole fractions has the highest priority in the round-robins, but laboratories are encouraged to measure multiple species if time and air consumption allow for.

### **1.3 General requirements for World Calibration Centres**

- a) A World Calibration Centre (WCC) performs audits of participating GAW laboratories and field stations as well as organizes round-robin comparisons (as per 1.2.m). More general terms of reference for WCC can be found in the GAW Implementation Plan for the period 2016-2023 (GAW Report No. 228) available on the WMO/GAW web page.

- b) Each WCC must have in-house standards re-calibrated by the CCL every two years. Longer re-calibration intervals might be acceptable only for compounds with proven long-term stability (e.g. SF<sub>6</sub>, CH<sub>4</sub>). The WCC calibration strategy should avoid unnecessary levels in the calibration hierarchy while keeping its highest level standards for many years so that a calibration history can be built for each of them. In that case they could then also serve as de-facto additional long-term "surveillance cylinders" providing information on the stability of the WMO Mole Fraction Scales maintained by the CCLs.
- c) Reference gas standards and travelling standards should be in dried natural air, and when trace gases, in particular CO<sub>2</sub>, are adjusted in reference air mixtures, the isotopic composition of the cylinder trace gas should remain close to that in air to minimize the influence of isotopic composition on calibrations, or measured isotopic ratio information should be provided (see 1.2k).
- d) GAW WCCs are encouraged to assist laboratories in improving their procedures when it becomes apparent from comparison programmes that those laboratories are operating well outside of WMO compatibility goals. The comparisons include the round robins and various comparisons of flask samples and continuous analyser systems. The CCL should be included in CH<sub>4</sub> and SF<sub>6</sub> comparisons organized by WCCs.
- e) The WCC for CO<sub>2</sub>, CH<sub>4</sub>, and CO (Empa) has demonstrated the benefits of using a travelling instrument for GAW station audits (Zellweger et al., 2016). It is very desirable that the air intake is included in the testing process. This practice is encouraged whenever possible. The benefit of using a "travelling" measurement system for a period of weeks and in parallel to existing station systems to evaluate the system performance has also been demonstrated by the ICOS development team (Hammer et al., 2013).

#### **1.4 Maintenance of calibration by GAW measurement laboratories**

- a) All laboratories that participate in the GAW Programme must calibrate and report measurements relative to a single carefully maintained conventional reference scale, the WMO Mole Fraction Scale for gas mole fractions in dry air, including its version number, or relative to the appropriate stable isotopic ratio scales. Each GAW measurement laboratory must actively maintain direct traceability to the WMO Scales, preferably obtaining a sufficient number and range of laboratory standards from the respective WMO/GAW CCL and transferring those calibrations to working and field standards. Laboratory standards should be regularly calibrated directly by the CCL or other traceable pathway (e.g. via a World or Regional Calibration Centre). For the stable isotopes, maintaining appropriate laboratory working standards is currently under responsibility of measuring laboratories. The data management system in use should allow for easy reprocessing and easy propagation of scale changes from laboratory standards to final measurement results.
- b) It is recommended that each WMO/GAW measurement laboratory maintains a strictly hierarchical scheme of transferring the calibration of its in-house tertiary

standards to working standards, and from working standards to atmospheric measurements. Traceability via a unique path will, in principle, enable the unambiguous and efficient propagation of changes (including retro-active changes) in the assigned values of higher-level standards all the way to measured values for atmospheric air. The uncertainty propagation at GAW measurement laboratories should include the uncertainties provided for calibration mixtures by CCL, and include all retrospective corrections, if propagated later on.

- c) It is recommended that each WMO/GAW measurement laboratory participate in the WMO round-robin comparisons held every two years. Each lab is expected to report their measured values and respective uncertainties. For the latter they should not report the repeatability of the few measurements made on the round-robin cylinders, but the more relevant measure of long-term reproducibility, which could be based on calibrations of surveillance tanks made over many years, or another equivalent method.
- d) To minimise the risk of creating offsets that are coherent among laboratories within the same region, each laboratory should maintain the shortest feasible direct link to the WMO Primary Standards, and/or engage in appropriate ongoing comparison activities to verify that the recommended WMO compatibility targets (Table 1) are being reached.
- e) Laboratories should, when they find inconsistencies between calibration gas mixtures received from the CCL, bring those results to the attention of the CCL.
- f) A rule of thumb for internal reproducibility goals is one half the compatibility goals given in Table 1. Internal reproducibility incorporates not only instrumental imprecision, but also uncertainties in transferring the calibration scale from the highest level of standards to working standards and other uncertainties, for example related to gas handling, at the field station or laboratory.
- g) Calibration and working standards should be contained in high-pressure aluminium cylinders. Steel cylinders are not recommended except for H<sub>2</sub> in which case stainless steel is recommended. Cylinder head valves should be packless, brass valves with PCTFE or metal seats, for H<sub>2</sub> the respective valve type made from steel or brass are appropriate.
- h) When prepared, calibration and working standards should be dried to a dewpoint of at most -70°C (at atmospheric pressure), corresponding to 2.6 ppm or less water vapour content.
- i) In the case of CO<sub>2</sub> the calibration standards should be replaced once the cylinder pressure has decreased to 20 bar. The maximum acceptable initial pressure for calibration standards is unclear, but is at least 140 bar, with little experience within the community at higher pressures.
- j) Cylinder regulators are a critical component of all analysis systems and a poor choice of regulator can significantly impact accuracy and precision. 'High purity' regulators should be used, and those with relatively small internal volume are preferred. In most applications two-stage regulators are ideal, as these ensure constant delivery pressure even as the cylinder pressure drops – particularly important at remote field stations. Brass or nickel-plated brass regulators (with metal diaphragms) have been found to give more stable results for CO<sub>2</sub>

measurement in some cases than stainless steel. The selection of a specific regulator model should be based on experimental evidence of its suitability for the purpose of delivering unchanged standard gases.

- k) Flushing times: Tests must be performed to ensure that cylinder regulators are sufficiently flushed during a measurement period. Regulator flushing times depend on regulator type, flow rate, and length of stagnation time since the regulator was last in use. When a regulator is first installed on a cylinder, it should be 'pressure-flushed' a minimum of four times, that is, draining the regulator from the cylinder pressure to ambient.
- l) We recommend the use of natural air for laboratory and working standards. If trace gas mole fractions are adjusted in reference air mixtures, in particular CO<sub>2</sub>, the isotopic composition of the cylinder trace gas should remain unchanged to minimize the influence of isotopic composition on calibrations, or the composition of the leading isotopologues of CO<sub>2</sub> standards should be analysed and provided with the mole fraction of CO<sub>2</sub>.
- m) It is not possible to recommend a definitive number of calibration standards since this depends on the characteristics of specific instruments used for the air measurements. For example, an ideal suite of standards would include:
  - i. Enough standards used in 'routine' instrument calibrations to define the  $r^2$  ('goodness of fit') parameter from a least squares fit of the instrument response (e.g. if the instrument response is fit to a quadratic function, then at least four standards are needed).
  - ii. For instruments with relatively variable baseline response, a so-called 'zero tank' (ZT) standard may be required to periodically adjust the offset of the baseline response.
- n) Calibration standards should bracket the range of observed mole fractions at the field station, and anticipate long-term trends in background atmospheric mole fraction.
- o) Frequency of calibration also depends on the instrument used, and control of the instrument environment, and thus specific recommendations cannot be given. Calibration frequency for a given instrument at a given location should be determined based upon:
  - i. Consideration of instrument drifts in baseline (zero), span and non-linearity (dependent on both the instrument and ambient environmental conditions). The calibration scheme should correct for such drifts. As a rule of thumb, we recommend frequency of calibration to define each of zero, span and non-linearity of the instrument to be half the time it typically takes for drift in these parameters to lead to a bias outside of the WMO compatibility requirements (Table 1).
  - ii. Consideration of results from initial 'target tank' (TT) analyses at the field station (see below). Variability in TT results should be about the same or less than the internal reproducibility goals.
  - iii. Prior experience or advice from experienced practitioners in the field.
- p) Any calibration analysis made at daily or lower frequency should be run at varying times of day to detect potential diurnal aliasing.



- q) Calibration analyses involving two or more standards should sometimes be run in opposite order to examine for incomplete flushing characteristics. (This requirement is unnecessary for measurement protocols where every sample or calibration measurement is bracketed by a working standard, but in this case incomplete flushing must be diagnosed through other means, for example by varying the duration of calibration measurements).
- r) Each analysis system must include at least one 'target tank' (TT; sometimes called 'surveillance tank'), which is a very important quality control tool for in situ measurement. Two TTs spanning a range in mole fraction for the measured species are preferred. Frequency of TT measurement should be once or twice a day, with the measurement time of day varying. An ideal analysis system allows the TT gas to pass through the same pumps, dryers and switching valves as the sample air, or less ideally, to be introduced to the instrument via the same path as calibration standards. As with calibration standards, the TT should be contained in a high pressure aluminium cylinder, must contain natural dry air, including trace gases and isotopic ratios to the extent possible, must be dried to a dew point of at most -70°C (at atmospheric pressure), and should be replaced once the pressure decreases to 20 bar.
- s) Care should be taken to maintain a single line of traceability of the calibration (see 1.4b above). The target tanks, or other additional standards, should not be used to define a second, optional, path of traceability. That only would create confusion and introduce an element of arbitrariness. Target gases function as a warning that there might be a problem that needs attention.

### **1.5 General recommendations for the quality control of atmospheric trace gas measurements**

To achieve the required levels of compatibility (see Table 1) it is important to understand and carefully consider the design of the whole analysis system including instrument, gas handling, calibration and data management. No single instrument type is recommended. Many can be used with equal success and none are fool proof when poor choices are made with gas handling or data management. A trade-off in instrument stability and complexity versus cost must often be balanced according to the needs, resources and challenges of the measurement programme.

For a more comprehensive discussion of recommendations and guidelines for best practice for in situ measurement, the reader is referred to Measurement Guidelines for CH<sub>4</sub> and N<sub>2</sub>O (GAW Report 185, 2009) and for CO (GAW Report 192, 2010), both available at <http://www.wmo.int/pages/prog/arep/gaw/gaw-reports.html>.

The following list of best practices is specifically for CO<sub>2</sub> measurement, however many of these practices also apply to the measurement of other gas species discussed in these recommendations.

- a) Investigators must report uncertainty estimates for their data that include all potential sources of error, including collection and treatment of the air before it enters the instrument. In addition, investigators are encouraged to include with their data an estimate of inter-laboratory measurement compatibility based on results from ongoing comparison of atmospheric measurements. Details of how these estimates are calculated and what activities are used to verify them need to be provided. ISO nomenclature (see details in introduction) shall be used for uncertainty estimates and compatibility discussions.
- b) It is important to ensure that the gas handling design and components used do not unintentionally affect the composition of the air sample or the calibration standards. For any novel design or component that has not previously proven acceptable in the published literature, tests must be carried out.
- c) We recommend further thorough elimination of leaks, minimization of thermal gradients, and horizontal storage of cylinders to minimize the risk of fractionation between the gas components in the cylinder.
- d) With respect to drying air samples:
  - i. Water vapour must either be removed from the sample gas stream, or its influence on the mole fraction determination must be carefully quantified (see 1.5.e below). Furthermore, water vapour and adsorbed water in the entire air intake line, as well as the possibility of accumulation of condensed water in low points, must be considered.
  - ii. Prior to analysis, sample air should be dried to a dew point of at most  $-50^{\circ}\text{C}$  (corresponding to at most 39 ppm water vapour content). If a cold trap is used the temperature should also be kept above  $-78^{\circ}\text{C}$  to prevent losing a small fraction of  $\text{CO}_2$ . These requirements are to ensure that WMO/GAW compatibility goals can be met. Water vapour effects influencing accurate mole fraction determination include spectroscopic interference, pressure broadening, mole fraction dilution, and transient surface effects from wetting and drying tubing walls. Note that drying to a dew point of  $-40^{\circ}\text{C}$  (127 ppm water vapour) leads to a 0.05 ppm dilution offset in a  $\text{CO}_2$  mole fraction of 380 ppm, if uncorrected. However, if recommendation iv is followed, especially with the use of Nafion<sup>®</sup>, then the reference gas is humidified to almost the same humidity level as the sample, which will relax the drying requirements somewhat. The Nafion<sup>®</sup> will dry out as the dry reference gas flows through so that its ability to humidify diminishes over time.
  - iii. Tests must be carried out to ensure that the residence time of sample air in the drying vessel is sufficient to achieve the anticipated level of drying, and that in the case of cryogenic drying ice crystals are not removed from the trap by large air flows.
  - iv. To prevent  $\text{CO}_2$  mole fraction offsets between very dry calibration standards and sample air, we recommend passing both calibration standards and sample air through the same drying vessel immediately prior to analysis (this will have the effect of 'wetting' the calibration standard).
  - v. The preferred method of drying is cryogenic, typically via a 'cold trap' immersed in an ethanol bath. Most chemical drying agents can absorb  $\text{CO}_2$

and are unsuitable. Magnesium perchlorate ( $\text{Mg}(\text{ClO}_4)_2$ ) can be used, but only under conditions of constant flow and pressure. Nafion<sup>®</sup> membrane dryers may be used, but also only under conditions of constant flow and pressure.

- e) Using water vapour measurements to correct measured  $\text{CO}_2$  mole fraction: Studies with Cavity Ring Down Spectroscopy (CRDS) instruments showed that correction functions can be used (Rella et al., 2013). However, the correction functions must be determined for each individual instrument. Furthermore, additional testing and verification studies are needed. These include, but are not limited to: side-by-side comparisons of two instruments, one with comprehensive drying of inlet air streams, the other with no drying and using water vapour correction factors. Side-by-side studies should take place for several months and under a variety of conditions, for example at locations with poor room temperature stability, on airborne or shipboard platforms, and at locations with very high ambient humidity (see e.g. Zellweger et al., 2016). Studies should also be carried out with partial drying and correcting for the residual water vapour. Studies should be carried out with different instrument models and instruments from different vendors.
- f) Flushing times: Flow should be fast enough and long enough to allow complete flushing of the instrument sensor cell after switching between different sample inlets or calibration standards. Elimination of “dead volumes” is essential for lowering the flushing requirement, which consumes valuable reference and sample gas.
- g) If instrument sensor cell pressure is not actively controlled, then cell pressure should be measured, and the pressure sensitivity of the instrument and its concentration dependence should be routinely determined.
- h) Where possible, instruments should be located in a stable temperature environment. If temperature of the room or immediate environs of the instrument is not actively controlled, then it should be measured, and the temperature sensitivity of the instrument and its concentration dependence should be routinely determined.
- i) Results from direct comparison of atmospheric data derived from different laboratories or using different techniques are valuable to assess the full uncertainty budget. In addition to participation in the WMO round-robin comparisons, investigators are required to participate in more frequent and ongoing comparison activities between pairs of laboratories, which incorporate the analyses of actual air samples. Comparisons of measurements from co-located in situ instruments and co-located discrete samples and in situ instruments are also strongly recommended. Atmospheric air comparison experiments at a single site by multiple laboratories such as those conducted at Alert, Cape Grim, and Mauna Loa are very valuable. The benefit of ongoing same-air comparisons has been demonstrated (Masarie et al., 2001). Mutual exchange of air in glass flasks is encouraged as a means to detect experimental deficiencies. Results from comparison activities are used only to expose measurement inconsistencies. Measurements should not be adjusted by WMO participants based on comparison results, but only when the cause of a measurement bias is understood and quantified. Regular comparison of data from various stations at similar settings (altitude, latitude, remoteness) can also help to timely identify instrumental issues with a particular measurement.

- j) Laboratories participating in ongoing comparison experiments must make comparison data electronically available to each other within a month after completion of the measurements. It is understood these data are preliminary and may contain undetected errors. Timely review of comparison results increases the likelihood of detecting experimental problems shortly after they develop. The main reason for sharing preliminary data is early detection of problems.
- k) Data comparisons require sufficient metadata to identify methodology differences that potentially influence quantitative comparisons. These metadata should be provided by the participants in the comparison programmes (ICP) to allow independent quantification of bias, and assumptions in comparisons should be specifically stated.
- l) To better understand the effectiveness of various comparison strategies, laboratories with ongoing comparison experiments are encouraged to report at GGMT meetings what they have learned, how the comparison has affected measurement quality and compatibility and the benefit of redundant or complementary comparisons. This will be needed to develop a comprehensive quality control strategy.
- m) Flask sampling programmes should be implemented where possible at observational sites making continuous measurements. This will provide ongoing quality control, help determine measurement uncertainty and allow the joint use of data sets from different laboratories. The Integrated Carbon Observation System (ICOS) will assess the benefit of having a "buffered" or time-integrated flask collection system to increase the representativeness of the flask sample as well as the precision of the comparison.
- n) Clear protocols and reports of experience gained in comparison projects should be provided. Results should be published and be made readily accessible via internet. The evaluation of such activities and recommendations for refinement, co-ordination and expansion of such activities has been accepted as a key responsibility of GGMT meetings.
- o) Engaging the remote sensing community in validation with ground-based measurements is essential for ensuring that trace gas retrievals can be used in high resolution analyses without introducing spatial and temporal biases. Such engagement should not be limited to the CCLs or WCCs alone, as individual scientists or research groups making vertical profile measurements can contribute significantly to this effort.
- p) Deviations from recommendations: We recognize the value of innovation and experimentation with new approaches. However, we stress that deviations from established practices should be fully tested to confirm that the new approach does not introduce bias into the measurements. The results of such experimentation should be reported at future GGMT meetings and similar venues, and published in the peer-reviewed literature whenever possible.
- q) Data management protocols for in situ measurement closely follow those given in Section 14 below for WMO/GAW laboratories. In particular, because of the typically larger volumes of data collected, we emphasise the necessity for automated routines both to produce mole fraction results from raw data and to retrospectively

recalculate mole fraction data owing to any revisions made to either the in situ calibration scale or the externally defined calibration standard mole fractions. Automated routines must also exist to provide frequent system diagnostic and quality control checks, and to alert the investigator to problems.

- r) A logbook, preferably in electronic form, must be maintained, documenting all problems that occur with the measurement system, downtimes, upgrades, routine maintenance, replacement of calibration standards, and any unusual local activity that might compromise the in situ sample measurements.
- s) For an atmospheric monitoring field station, a good practical setup is to measure at least one or two atmospheric species continuously in situ, complemented with meteorological data, whilst datasets of other species are obtained via flask sample collection. The in situ measurement of additional parameters is recommended, as it is beneficial for data interpretation and quality control.

### **1.6 Recommendations for the assessment of new in situ measurement technologies and/or instruments**

An overarching and ongoing objective is to simplify all steps of the measurement process, by making operations routine and increasing standardisation, so that carrying out measurements is more accessible to a wider group of scientists, while reducing costs – both start-up and ongoing.

The following topics require further research before recommendations for best practice can be defined or revised. We strongly encourage the community to investigate these topics and report their findings at subsequent WMO/IAEA GGMT meetings.

- a) We encourage the development of new or improved techniques that would lead to improvements in precision and reproducibility, which includes methods that reduce the consumption of calibration gas. Experience and results obtained with new techniques should be shared with the community through web-based discussion groups or scientific publications.
- b) We recommend that new analytical technologies (e.g. laser-based optical analysers, closed-cell Fourier Transform spectrometers) are tested (e.g. Tuzson et al., 2011; Hammer et al., 2013; Morgan et al., 2015; Lebegue et al., 2016). New techniques should meet the scientific requirements of accuracy and precision as stated in GAW reports. Specific areas that need to be investigated are calibration frequency and ability to correct for water vapour dilution or interference with other trace substances, and other artefacts besides sample drying. Manufacturers are encouraged to offer detailed technical training, perhaps through the GAW Training and Education Centre (GAWTEC, <http://www.gawtec.de>) if requested by the community. The community should identify species for which new technologies are needed and formulate desired specifications for instruments that can measure new observables.
- c) *Instrument Characterization*: The goal of these tests is to perform a basic assessment of the suitability of the instrumentation for the application, as well as to

provide input for constructing an appropriate calibration strategy for the instrument. The following parameters should be characterized using controlled test conditions.

- Noise: Instrument noise should be measured using known dry air from cylinders, under the following conditions. The total time period for this test should extend to well beyond the expected time period between in situ instrument calibrations or target tank measurements. Regular calibrations should be performed during this test. Allan variance plots can then be constructed with or without (a subset of) the calibrations, so that the plots are informative for the choice of an optimal calibration strategy.
- Linearity: the linearity of the instrument should be assessed, with traceability to the WMO or other standard scales. Three standards well separated from each other is the minimum number to establish linearity.
- Response time: The response of the instrument to step function changes of the input gas mole fraction should be quantified with dry gas mixtures. This test establishes the effective time constant of the instrument at a given flow rate, and is relevant for how standards are introduced. The response of the instrument should also be characterized in response to step function changes in a) humidity, and b) inlet pressure, c) flow rate.
- Environmental conditions: Potential systematic biases associated with the instrument response to environmental temperature, pressure, and humidity changes should be evaluated over the range of environmental conditions expected during deployment.
- Interfering species: The systematic bias of the instrument response to the introduction of interfering atmospheric species to the gas inlet should be assessed. A complete assessment is not practical, but interferences from the principal atmospheric constituents should be measured. Each technology and application will suffer from different potential interference, so likely candidates should be selected and prioritized from the following list, with technical input from the manufacturer of the instrument.
  - Water vapour
  - Carbon dioxide
  - Methane
  - Composition of main air components N<sub>2</sub>, O<sub>2</sub>, and Ar
  - Nitrous oxide
  - Isotopes of the primary concentration measurement or potential interfering species
  - Other trace species

d) *In situ Application Validation*: The instrument should be located at the measurement site or at an appropriate proxy site for long term monitoring. Drift of the instrument response function should be quantified over a long period, preferably six months or more, using known reference standard mixtures. The time between individual standard measurements should be at most 1 week (< 1 day preferred) to capture more rapid variability. A ~10 day subset of this time should

be sampled at a higher frequency (several times per day) to capture diurnal systematic errors in instrument performance. The instrument should be evaluated hourly (or other time interval suitable to the application) against 1) another well-validated in situ monitoring technology AND 2) co-sampled flasks that are analysed at an established laboratory using proven methodology. With increasing duration of the validation period, additional confidence is gained in the performance of the new technology. A target comparison period of 1 year or greater should be the goal, but the interim results provide a very valuable initial assessment. For a full assessment of the uncertainty of the measurement system the air sample inlet and air preparation, such as drying, needs to be included in the evaluation.

- e) *Communication:* Those involved with instrument validation and testing are encouraged to publish their findings in a peer-reviewed publication for dissemination to the wider community and to provide a reference for citation.
-

## 2. SPECIFIC REQUIREMENTS FOR CO<sub>2</sub> CALIBRATION

### 2.1 Background

The general goals for compatibility of measurements of CO<sub>2</sub> in air are stated above in Table 1. The target of 0.1 ppm for the Northern and 0.05 ppm for the Southern Hemisphere is intended to address small, globally significant gradients over large spatial scales (for example caused by Southern Ocean fluxes). However, in polluted or vegetated continental regions, the annual-mean fluxes of interest leave small imprints on mole fraction gradients in the free troposphere, especially on an annual mean basis in the highly-variable boundary layer so that a target of 0.1 ppm is still needed. However, for certain local, for example urban, studies the extended compatibility goal of Table 1 may be appropriate.

NOAA/ESRL serves as CCL for CO<sub>2</sub> for the GAW Programme. The current (June 2016) version of the WMO mole fraction scale for carbon dioxide is WMO CO<sub>2</sub> X2007.

The range of the WMO CO<sub>2</sub> X2007 scale is from 250 to 520 ppm, but the CCL has cylinders that have been measured several times manometrically ranging from 70 ppm (covering atmospheric values in ice cores) to 3000 ppm (covering CO<sub>2</sub> partial pressures in the oceans). The WMO scale is currently embodied in a set of 15 CO<sub>2</sub>-in-dried-air mixtures in large high-pressure cylinders covering the ambient range 250-520 ppm, while another set of 20 cylinders provide both a backup and a much larger range.

### 2.2 Recommendations for CO<sub>2</sub> calibration and comparison activities

- a) Since the WMO scale was maintained until 1995 by Scripps Institution of Oceanography (SIO), comparisons with SIO are especially relevant. It is recommended that remaining uncertainties associated with the SIO pre-1995 WMO scale and its transfer to NOAA are resolved.
- b) The CO<sub>2</sub> isotopic composition of distributed reference standards should anticipate the evolution of CO<sub>2</sub> and its isotopic ratios in background air when the standards are intended to be kept for decades, in order to avoid isotopic measurement bias during instrument calibration. The isotopic composition of distributed standard gases should be reported by the CCL as information values, at the precision required to minimize potential biases of total CO<sub>2</sub> calibrations well below WMO compatibility goals (0.03 ppm, see 2.2.d). These information values are thus not isotopic calibration values.
- c) The CCL is encouraged to make available on its web site calibration results of all GAW laboratory standards based on the current scale.
- d) To make possible a level of compatibility of  $\pm 0.03$  ppm or less among the CO<sub>2</sub> calibration scales of laboratories participating in the WMO/GAW Programme, the CCL shall aim to transfer the CO<sub>2</sub> scale to secondary and tertiary standards at that level of consistency.



- e) Each WMO/GAW measurement laboratory must actively maintain its link to the WMO Scale by having a subset of its in-house highest level standards for CO<sub>2</sub> (covering the measurement range) re-calibrated by the CCL at least every three years. A network calibration centre of GAW partners must do the same, as standard procedure, except at least every two years (see 1.3b).
-

### 3. SPECIFIC REQUIREMENTS FOR STABLE ISOTOPE CALIBRATION

The target values for compatibility of stable isotope measurement results of CO<sub>2</sub> and CH<sub>4</sub> in air are presented in Table 1 above. These targets are required to achieve reasonable signal/noise ratios when addressing small yet globally significant gradients over large spatial scales, for example, Southern Ocean isotopic disequilibrium fluxes.

Given that ecological or biogeochemical studies of predominantly local or regional significance deal with larger signals in time and space, the compatibility goals for such studies can be extended and a coarser measurement uncertainty can be tolerated (Table 1). The total combined uncertainty tolerated for local studies are intended to scale with the magnitude of the gradients studied. More details are given in Section 11.

#### 3.1 Background

The importance of stable isotope characteristics for assigning GHG sources, fluxes, and tracking their changes is well recognised. So far all stable isotope determinations are traceable to the highest level reference materials (e.g. artefacts NBS19 and VSMOW2) which are currently used for realisation of the VPDB ( $\delta^{13}\text{C}$  3DB ( $^{18}\text{O}$  in CO<sub>2</sub>)) scale definition and for the VSMOW ( $\delta^2\text{H}$  and  $\delta^{18}\text{O}$  in general). Notably, VIM 3 (2008) specifies VSMOW2 as the recognised international measurement standard for the realisation of the VSMOW scale (the scale is not SI-traceable); in the same way NBS19 is recognised by the International Union of Pure and Applied Chemistry (IUPAC) for the realisation of the VPDB scale (Brand 2010). This means that presently all measurement results and all uncertainty propagation should be done relative to the scales in use, based on the realisation materials. In turn, the IAEA is responsible for making such materials available, at the uncertainty levels as necessary to realise WMO - Data Quality Objectives (Table 1).

Improvements in the determination of absolute stable isotope ratios as well as the recognition of the role of stable isotope values on precise atomic weights and their role in new measurement techniques have encouraged a broader participation from National Metrology Institutes (NMIs) and from the BIPM. As a consequence, improved traceability of isotope ratios has found new interest as well and will become more important in the near future. The GGMT participants welcome this development and seek a closer cooperation between the WMO CCLs and the NMIs for improving metrological traceability and uncertainty evaluation for all kinds of reference materials used for atmospheric measurements.

The Max-Planck Institut für Biogeochemie (MPI-BGC), Jena, Germany serves as the CCL for the stable isotopes of CO<sub>2</sub> in air for the GAW Programme. The CCL activity is based on work performed at the MPI-BGC in collaboration with Environment Canada (Canada) and with the National Institute for Environmental Studies (NIES), Tsukuba, Japan since 2001. As a result, MPI-BGC offers the scale realization in the form of CO<sub>2</sub> in reference air (Jena Reference Air Set, (JRAS)), with the aim to reach the scale realization compatibility of  $\pm 0.01\text{‰}$  for  $\delta^{13}\text{C}$  and  $\pm 0.025\text{‰}$  for  $\delta^{18}\text{O}$ . This CO<sub>2</sub> isotope scale realization is named as JRAS-06.

Following the 15th WMO/IAEA Meeting (GGMT-2009), a number of laboratories have implemented JRAS as their calibration anchor for stable isotope measurements of CO<sub>2</sub> in air. In order to reach the compatibility targets (Table1), this process needs to be followed further until the results from various comparisons exhibit improvements in scale harmonization.

Currently the results of inter-comparisons for  $\delta^{13}\text{C}$  and  $\delta^{18}\text{O}$  presented at the Meeting (poster GGMT2015\_A20\_Ernst.pdf) demonstrates that since 2009 laboratories appear to continue showing consistent offsets and variability relative to the NOAA/INSTAAR data appear to get worse over time.

Results from ongoing inter-laboratory comparison programmes, has led to an extension of the service provided by the Central Calibration Laboratory for stable isotopes of CO<sub>2</sub> in air. In addition to the provision of reference materials in the form of JRAS sets in 5-L glass flasks (carbonate-CO<sub>2</sub> in air, with  $\delta^{13}\text{C}$  close to +1.9‰ and dry ambient air with  $\delta^{13}\text{C}$  close to -8‰), MPI-BGC in Jena will continue to perform isotopic calibration of high pressure air tanks provided by participating laboratories. These materials with different  $\delta^{13}\text{C}$  values represent the JRAS-2006 scale realisation. As air-flasks or tank air have  $\delta^{13}\text{C}$  values close to actual samples, these are intended to be used as the immediate calibrator for the VPDB-CO<sub>2</sub> scale. The JRAS flasks with CO<sub>2</sub> from calcites can be used as measurement quality checks, in order to test instrument performance (specific effects such as scale contraction 'η' -effect, extraction effects etc.) and potentially to quantify corrections. As all measurements at MPI-BGC comply with the NBS19 – LSVEC normalization on the  $\delta^{13}\text{C}$  VPDB scale, the calibration scheme as given above is consistent with this scale.

In light of the scarcity of NBS 19 and new information presented by S.S. Assonov (IAEA) regarding limited suitability of LSVEC as a reliable scale anchor new scale access reference materials are currently under review. This might have an impact on future carbon isotope scale realisations. The CCL is asked to keep an eye on this development and provide corrective action when needed.

WMO is now at the discussion stage with IAEA concerning potential joint activities related to isotopic reference materials. It is expected that a concrete cooperation plan is developed and presented at the next GGMT meeting in 2017.

Estimating the total combined uncertainty of measurement results and traceability to the VPDB-scale, the corresponding data for each JRAS flask and air tank calibrated on the JRAS-2006 scale are key points and need to be provided by the CCL. Hence, further efforts by the CCL (MPI-BGC) and the participating laboratories are necessary. The practical realization and future steps are discussed further below.

### 3.2 Current calibration and comparison activities of the stable isotopes of CO<sub>2</sub>

The major aspects/problems for achieving harmonized stable isotope ratio measurement results for CO<sub>2</sub> in air are:

- a) Scale contraction ( ‘ η ’ -effect) during calibration of mass spectrometric measurements. While this affects both  $\delta^{13}\text{C}$  and  $\delta^{18}\text{O}$  measurements, where measurements are referred directly to the scale origin (defined by NBS-19) the greatest impact is on  $\delta^{13}\text{C}$  of CO<sub>2</sub>, as in ambient air this is 10‰ away from the reference.  $\delta^{18}\text{O}$  is generally less than 4‰ different from the scale origin. Ion source materials as well as ion source flushing times (idle time) are major parameters responsible for this effect. The effect of the latter can be tested, by taking idle time as variable.
- b) For  $\delta^{18}\text{O}$ , exchange with water during sample storage is a potential problem, to be addressed by air drying and flask pre-treatment. Inconsistent calibrations between laboratories is another potential problem to be brought under control.
- c) Further inconsistencies between laboratories can arise from different algorithms and/or parameterizations of the necessary corrections for <sup>17</sup>O and N<sub>2</sub>O.
- d) Failure to report assignment uncertainties in the isotopic composition of gas/gas mixture used as a reference.
- e) Failure to estimate and report total combined uncertainty of the data as traced to the VPDB-scale and also failure to provide the uncertainty budget.

Most of these issues have been fully recognized and discussed (Verkouteren et al., 2003a; Verkouteren et al., 2003b; Wendeberg et al., 2011; Wendeberg et al., 2013). Laboratories are welcome to quantify each effect separately; also optimisation of ion source tunings is shown to minimise some effects. Tests aimed to quantify the magnitude of memory or cross contamination (Ghosh et al., 2005; Verkouteren et al., 2003a; Verkouteren et al., 2003b) performed locally may prove more efficient when aspects of sample extraction and mass spectrometric measurement can be studied separately.

Further progress in this area requires the availability of whole-air standards (calibration mixtures and/or characterised air) which closely mimic samples under analysis. In this way effect of instrumental corrections and its potential instability will be minimised. These whole-air standards have to be reliably characterised on the VPDB-CO<sub>2</sub> scale by the Central Calibration Laboratory.

For a reliable compatibility assessment between laboratories and reliable uncertainty estimation, generation and maintenance of the full measurement traceability chain to the VPDB scale is necessary and should be provided. For this purpose, the CCL is requested to provide the full measurement traceability chain on the VPDB scale for all calibration measurements as well as the full error budget of all materials distributed by the CCL; these should be made publicly accessible on the JRAS web site.

Participating laboratories can base their measurement traceability chain on the material calibrated by the CCL and include all corrections required locally. The uncertainty propagation should include all uncertainty sources such as the uncertainty assigned to the calibration material, uncertainties of all measurement steps involved as well as the combined uncertainties of all corrections. The carbonate-based CO<sub>2</sub> JRAS flasks should be used as a measurement quality check and not be included in the uncertainty estimation.

Furthermore, progress in the compatibility assessment is visualized by the results of various inter-laboratory comparison programmes.

### **3.3 Recommendations for CO<sub>2</sub> stable isotope calibration and comparison activities**

The CCL is selected and designated to assure for long-term compatibility of all calibrations used for stable isotope measurements in GHG (presently CO<sub>2</sub>), by providing appropriate calibration mixtures (or characterised natural air), with all measurements and property values assigned to be fully traceable to the respective international isotope scales in use (e.g. VPDB for  $\delta^{13}\text{C}$ ), including the total combined uncertainty assigned. The CCL may also provide recommendations for the best calibration transfer practices at user-laboratories. The CCL activity has to include full documentation of mixture preparation in such detail as needed to reproduce all the work (in case of a catastrophic event).

Specific recommendations include:

- a) *Data management and data submission:* All raw data must be archived in a way to facilitate data re-processing, in case such a need will arise from reference gas re-calibration or other corrections to be applied retrospectively. Reported measurement results must be accompanied by total combined uncertainties, including the uncertainty of scale realization (e.g. calibration material in use) and all potential sources of error such as all instrumental corrections and errors related to the CO<sub>2</sub> extraction. The total combined uncertainty must be reported on the VPDB-scale and be traced (by calibration) to the primary isotope standard, NBS 19.
- b) *<sup>17</sup>O-correction:* For accounting for the <sup>12</sup>C<sup>16</sup>O<sup>17</sup>O contribution from the mass spectrometric signals measured on mass 45, the method described in Assonov and Brenninkmeijer (2003a,b) is agreed to be the standard procedure and manufacturers of mass spectrometers are asked to update their corresponding software accordingly. A sufficiently accurate linearized version of this method (Brand et al, 2010) can facilitate the transition from any previously used <sup>17</sup>O correction method. Further, to ensure that the effect of the <sup>17</sup>O-correction is kept at a minimum, the use of air reference mixtures is recommended and the use of reference materials with a large deviation in  $\delta^{18}\text{O}$  (e.g. NBS 18) should be avoided. To provide a consistent link to the VPDB-CO<sub>2</sub> scale as defined through NBS 19-CO<sub>2</sub>, the CCL is advised to apply corrections based on the Assonov-Brenninkmeijer ratio assumption set exclusively.

- c) *N<sub>2</sub>O-correction*: The N<sub>2</sub>O correction has been the subject of several publications, which through different experimental approaches lead to a common size for the correction. The CCL is asked to implement the required correction on distributed reference gases and verify its validity over time. With the provision of reference air (which contains N<sub>2</sub>O), biases in the N<sub>2</sub>O correction of different laboratories will be extremely small and should not affect compatibility of results and/or scale realisation. As a control measure, the CCL is asked to analyse air with varying N<sub>2</sub>O mole fractions on request (also without N<sub>2</sub>O) for the participating laboratories.
- d) *JRAS*: The Jena Reference Air Set has been designed in order to improve data compatibility. Recently, the Jena Reference Air Set has been expanded to include a reference point at atmospheric CO<sub>2</sub> levels ( $\delta^{13}\text{C} \approx -8\text{‰}$ ). The measurement traceability chain at end-user laboratory and the uncertainty propagation has to be based on the JRAS calibration material with  $\delta^{13}\text{C} \approx -8\text{‰}$ , with the second material ( $\delta^{13}\text{C}$  close to + 2‰ or -4‰) to be used as quality check and test for instrumental effects. In lieu of a calcite with suitable isotope composition, clean air has been used for this purpose.
- e) *Inter-Laboratory Comparisons*: All laboratories are encouraged to continue their participation in the existing inter-laboratory comparison activities. Inter-laboratory comparison activities should address all possible sources of discrepancies and biases. A comprehensive comparison activity should include all forms of samples, i.e. flasks as well as low- and high-pressure cylinders or pure CO<sub>2</sub> ampoules like the Narcis sets still available from NIES. Reported values must be accompanied by estimates of total uncertainties, based on a calibration/measurement traceability chain. Laboratories that have long histories of participating in inter-laboratory comparisons are encouraged to re-assess their comparison data in light of present recommendations regarding corrections and ensure compatibility with current inter-laboratory comparisons.
- f) *Instrument-specific scale contraction*: Investigations of instrument-specific influences on scale contraction are needed (Meijer et al., 2000; Verkouteren et al., 2003a; Verkouteren et al., 2003b). Operational instrument parameters and analytical protocols to minimise the scale contraction effect, to monitor its magnitude over time, and to correct for it should be implemented locally. The information on cross-contamination tests, its magnitude and corrections, if applied, should be provided together with the data in publications, by data centres and on web sites where applicable.
- g) *Selection of laboratory working gases*: During isotope ratio mass spectrometer (IRMS) measurements, scale contraction and memory effects critically depend on the reference gases in use. More specifically, the results are affected by the isotopic distance between these gases. To minimize such effects, the isotopic composition of the working reference gases should be as close as possible to that of CO<sub>2</sub> in ambient air. In addition, investigators are encouraged to include with their data an estimate of inter-laboratory measurement compatibility based on results from ongoing comparison of atmospheric measurements.

- h) *JRAS-scale realisation*. MPI-BGC is asked to document details of the preparation of JRAS sets and high pressure air tanks and their calibration on the VPDB-scale, including the total combined uncertainty propagated to the VPDB-scale, the uncertainty budget. The description should be available on the MPI-BGC web page and revised on a regular basis.

### 3.4 Isotopic measurements from emerging optical techniques

In recent years, optical analysers that report mole fractions of individual isotopologues have become available and are now in routine use. Many of these instruments can provide isotopic ratios with a precision of around 0.1‰ for  $\delta^{13}\text{C}$  of atmospheric  $\text{CO}_2$  or better and are valuable for continuous measurements. Unlike mass spectrometric techniques,  $\delta$  values from such instruments are often calculated from the ratio of individual measured mole fractions using tabulated absorption line strengths and are not from direct measurements of a standard material. The reference isotopic abundance is normally taken from a spectral parameter database (typically HITRAN) that is used in the analysis, and this does not provide a common scale such as VPDB or JRAS. Some corrections applicable to mass spectrometric methods, such as those for  $^{17}\text{O}$  and  $\text{N}_2\text{O}$  are not required, but other corrections, depending on the method used to calculate the isotopic " $\delta$ " values from individual mole fractions, such as interference from other atmospheric components and instrument fluctuations, may be required. Thereafter, calibration and drift-correction for optical instruments should be done based on  $\text{CO}_2$ -in-air characterised by the traditional IRMS method.

#### Recommendations

- a) To determine calibrated amounts of individual isotopologues in a sample, both the whole species mole fraction and the isotopic composition of at least all singly-substituted isotopologues must be provided by the CCL for the calibration gases to enable isotopologue-specific calibration of the analyser.
- b) Measured isotopic " $\delta$ " values must be related to the accepted scales, such as VPDB for  $\text{CO}_2$ , calibrated against standards of known isotopic composition on the relevant reference scales.
- c) Developers and providers of optical analysers which deliver isotopic analyses should follow an open-source software philosophy, i.e. make available and distribute to the user communities all relevant algorithms used in the calculation of calibrated  $\delta$  values, as well as the relevant primary measurements used to derive isotopologue amounts and calculated  $\delta$  values. This will ensure comparability across instrument types, manufacturers and measurement laboratories, and allow checking and reproducing procedures as well as corrections by individual operators. Measurement information may include pressures, temperatures, optical path lengths, spectra, absorption line peak heights, areas or widths, as appropriate. Algorithm details should include all relevant calculations and corrections for variations such as those in water vapour and other interfering gases, pressure and temperature fluctuations and variations in mole fraction of each isotopologue.

- d) A particular emphasis should be laid on matrix effects, which are specific for the specific line set selected by the vendor. Such matrix effects must be made public in great detail. Related changes and improvements are important information to be disseminated and documented in detail.

### **3.5 Isotopologues of N<sub>2</sub>O and CO**

Growing interest in measuring the stable isotopic composition of nitrous oxide and carbon monoxide in air will drive the need for a standardized calibration for these species in ambient air. In collaboration with IAEA, a group will be formed to investigate strategies for providing a calibration of stable isotope ratios, including all isotopologues of these gases in air to the accepted international stable isotope scales and for preparing and providing secondary standards and/or recommendations on preparation steps to be distributed to capable laboratories.

### **3.6 Recommendations for CH<sub>4</sub> isotope calibration and comparison activities**

The need for a standardized isotopic calibration of methane in air ( $\delta^{13}\text{C}$  and  $\delta\text{D}$ ) has been recognized. New strategies for preparing isotopically characterized methane in air linked to the accepted IAEA scales (V-SMOW, VPDB) have been presented (P. Sperlich, work done at MPI-BGC). A possible distribution of CH<sub>4</sub>-in-air mixtures in the way similar to JRAS mixtures is thought to improve the  $\delta\text{D}$  and  $\delta^{13}\text{C}$  data compatibility between institutes.

In order to address the current need to urgently improve  $\delta^{13}\text{C}$  calibration of methane as well as understand and quantify instrumental effects and related corrections, the National Institute of Water and Atmospheric Research (NIWA) has offered to prepare a suite of high pressure cylinders of methane in air and to determine the carbon stable isotopes. Extension of the Jena JRAS set to methane isotopes was presented as a possibility for harmonizing local methane isotope scales. Further regular comparison of results from flask samples between laboratories (e.g. within the sausage comparison activity) is encouraged.

---



## 4. SPECIFIC REQUIREMENTS FOR THE CALIBRATION OF RADIOCARBON IN TRACE GASES

### 4.1 Background

Standardization of radiocarbon analysis has been well established in the radiocarbon dating community for many years, and Oxalic Acid Standard and the new Oxalic Acid Standard (NIST SRM 4990C) have been agreed upon as the main standard reference materials. Other reference materials of various origins are available and distributed by IAEA and some other agencies.

Atmospheric  $^{14}\text{C}$  measurements are usually reported in  $D^{14}\text{C}$  notation, the deviation from the absolute radiocarbon reference standard (Stuiver and Polach, 1977):

$$\Delta^{14}\text{C} = \left\{ \left[ \frac{R_{\text{sam}}}{R_{\text{ref}}} \right] \left[ \frac{0.975}{\left( 1 + \frac{\delta^{13}\text{C}}{1000} \right)} \right]^2 \exp(\lambda(1950 - t)) \right\} - 1$$

with  $R = ^{14}\text{C}/\text{C}$ , the corrections are for fractionation and radioactive decay ( $\lambda$ ) of the standard and reported in per mil (‰). The date used for the decay correction (typically the date of collection) should be reported with the result.  $\delta^{13}\text{C}$  should also be reported if it was measured on the original sample (e.g. atmospheric  $\text{CO}_2$ ), along with the  $\delta^{13}\text{C}$  measurement method. Note that  $\delta^{13}\text{C}$  measured by AMS may be fractionated from the original sample material and we strongly recommend that this value, although used to calculate  $D^{14}\text{C}$ , should not be reported.

When  $D^{14}\text{C}$  is used to calculate fossil fuel  $\text{CO}_2$  content, the  $^{13}\text{C}$  Suess Effect is neglected, introducing a slight bias. This can be solved by using  $\delta^{14}\text{C}$  (Stuiver and Polach, 1977) if the original sample  $\delta^{13}\text{C}$  is known, but as some sampling strategies preclude measurement of ambient  $\delta^{13}\text{C}$ , we recommend  $D^{14}\text{C}$  be reported to provide consistency amongst laboratories.

For atmospheric measurements of  $D^{14}\text{C}$  in  $\text{CO}_2$ , two main sampling techniques are used: High-volume  $\text{CO}_2$  absorption in basic solution or by molecular sieve and whole-air flask sampling (typically 1.5-5 L flasks). Two methods of analysis are used: conventional radioactive counting and Accelerator Mass Spectrometry (AMS). The current level of measurement uncertainty for  $D^{14}\text{C}$  in  $\text{CO}_2$  is 1-5‰. As atmospheric gradients in background air are currently very small, a target of 0.5‰ compatibility is recommended (Table 1). We emphasize again that compatibility is a measure of how well measurements from different instruments and laboratories can be compared over the long-term, and is not the individual measurement certainty.

Atmospheric  $^{14}\text{CH}_4$  measurements are also reported in  $D^{14}\text{C}$  notation. Atmospheric  $^{14}\text{CO}$  is usually reported in molecules per cubic centimetre. For both species, samples are typically collected into large tanks able to collect sufficient whole air for  $^{14}\text{C}$  measurement. For  $^{14}\text{CO}$ ,

extra care is taken to avoid, or account for, in situ production of  $^{14}\text{C}$  inside the tanks due to thermalized neutrons. The tank material is critical for stability and aluminium is preferred (Lowe et al., 2002). The species of interest is extracted from whole air and converted to  $\text{CO}_2$  prior to graphitization and AMS measurement.

#### 4.2 Current $^{14}\text{C}$ calibration and comparison activities

The first comparison activity for  $\Delta^{14}\text{C}$  in  $\text{CO}_2$  was initiated at the 13<sup>th</sup> WMO/IAEA Meeting of  $\text{CO}_2$  Experts in Boulder, Colorado, and is ongoing about once per year (Miller et al., 2013). Laboratories participated by sending flasks to NOAA/ESRL to be filled with air from two whole-air reference cylinders for  $\text{CO}_2$  extraction, target preparation and  $^{14}\text{C}$  AMS analysis. A similar comparison between laboratories within China began in 2015. A comparison of conventional and AMS  $^{14}\text{C}$  analysis was begun in 2014.  $\text{CO}_2$  from whole air was measured by gas counting at University of Heidelberg and subsequently aliquots of the same pure  $\text{CO}_2$  were distributed to AMS labs for measurement; this pure  $\text{CO}_2$  comparison will be ongoing (Hammer et al., this meeting). Plans for future atmospheric  $^{14}\text{C}$  comparison exercises are laid out in the report of the atmospheric  $^{14}\text{CO}_2$  workshop at the 21<sup>th</sup> International Radiocarbon Conference (Turnbull et al., 2013; Lehman et al., 2013). The comparison exercises indicate that compatibility between labs is 2-4 ‰, short of the 0.5‰ goal but generally consistent with the single sample uncertainties currently reported by each laboratory. We note that some ad-hoc comparisons have met the compatibility goal.

#### 4.3 Recommendations for $^{14}\text{C}$ calibration and comparison activities

- a) We recommend that laboratories conducting small-volume flask sampling and AMS analysis should use whole air cylinders as a target/surveillance material and, potentially, as a secondary standard.
- b) Reported uncertainties should reflect long-term repeatability of target materials as well as counting statistical uncertainties. A sufficiently detailed description of how the uncertainty was determined should be reported with results.
- c) We recommend continuation of the whole-air and pure- $\text{CO}_2$  comparison exercises at a frequency of once per year or more frequently and expansion of participating laboratories and with multiple measurements to increase the statistical robustness of the results.
- d) It is also recommended that laboratories participate in comparison exercises conducted by the wider radiocarbon community (Scott et al., 2010).
- e) We recommend co-located sampling at observation stations to compare the full measurement process, where possible.
- f) We recommend ongoing workshops to discuss comparability and standardisation for  $\Delta^{14}\text{C}$  in  $\text{CO}_2$  measurements and to harmonise the data from different laboratories.
- g) We recommend efforts to reduce measurement uncertainty, to generally improve the usefulness of  $\Delta^{14}\text{CO}_2$  results, and because trends in atmospheric composition are gradually reducing the sensitivity of  $\Delta^{14}\text{CO}_2$  to local fossil fuel  $\text{CO}_2$  additions.

#### **4.4 Calibration and comparison activities for $^{14}\text{C}$ in other trace gases**

No calibration materials or comparisons for other trace gases ( $^{14}\text{CH}_4$ ,  $^{14}\text{CO}$ , others) are currently active. We recommend that members of the radiocarbon community with interest and experience in these species consider developing reference materials and comparison exercises.

---

## 5. SPECIFIC REQUIREMENTS FOR O<sub>2</sub>/N<sub>2</sub> CALIBRATION

### 5.1 Background

Measurements of the changes in atmospheric O<sub>2</sub>/N<sub>2</sub> ratio are useful for constraining sources and sinks of CO<sub>2</sub> and testing land and ocean biogeochemical models. The relative variations in O<sub>2</sub>/N<sub>2</sub> ratio are very small but can now be observed by at least six analytical techniques. These techniques can be grouped into two categories: (1) those which measure O<sub>2</sub>/N<sub>2</sub> ratios directly (mass spectrometry and gas chromatography), and (2) those which effectively measure the O<sub>2</sub> mole fraction in dry air (interferometric, paramagnetic, fuel cell, vacuum ultraviolet photometric). A convention has emerged to convert the raw measurement signals, regardless of technique, into equivalent changes in mole ratio of O<sub>2</sub> to N<sub>2</sub>. For mole-fraction type measurements, this requires accounting for dilution due to variations in CO<sub>2</sub> and possibly other gases. If synthetic air is used as a reference material, corrections may also be needed for differences in Ar/N<sub>2</sub> ratio. By convention, O<sub>2</sub>/N<sub>2</sub> ratios are expressed as relative deviations compared to a reference

$$\delta (O_2/N_2) = (O_2/N_2)_{\text{sample}} / (O_2/N_2)_{\text{reference}} - 1$$

in which  $\delta (O_2/N_2)$  is multiplied by 10<sup>6</sup> and expressed in “per meg” units. Per meg is a dimensionless unit equivalent to 1 per meg = 0.001 per mil (Coplen, 2011). The O<sub>2</sub>/N<sub>2</sub> reference is typically tied to natural air delivered from high-pressure gas cylinders. As there is no common source of reference material, each laboratory has employed its own reference. Hence it has not been straightforward to report measurements on a common scale. There is currently no CCL for O<sub>2</sub>/N<sub>2</sub>. Several laboratories report results on the Scripps scale, but there are no named versions.

There is considerable scientific value to be gained from different laboratories reporting O<sub>2</sub>/N<sub>2</sub> measurements on a common scale. The O<sub>2</sub>/N<sub>2</sub> measurement community recognizes the Scripps O<sub>2</sub> Scale as the best candidate for a common reference. With a medium-term goal of establishing this as the common scale for reporting and comparing O<sub>2</sub>/N<sub>2</sub> measurements, in the near-term we recommend that all O<sub>2</sub>/N<sub>2</sub> measuring laboratories participate in the Global Oxygen Laboratories Link Ultra-precise Measurements (GOLLUM) comparison exercise, and we recommend that laboratories begin taking steps to link their internal laboratory scales directly to the Scripps O<sub>2</sub> Scale. In support of this, we recommend that the Scripps O<sub>2</sub> Laboratory continue to provide measurements for other laboratories on a cost-recovery basis, with a targeted turn-around time of 5 weeks for existing tanks, and also continue to provide service for filling and calibration of new tanks with a target turn-around time of 6 months.

The practice of basing O<sub>2</sub>/N<sub>2</sub> measurements on natural air stored in high-pressure cylinders appears acceptable for measuring changes in background air, provided the cylinders are handled according to certain best practices, including orienting cylinders horizontally to minimize thermal and gravitational fractionation. Nevertheless, improved understanding of the source of variability of measured O<sub>2</sub>/N<sub>2</sub> ratios delivered from high-pressure cylinders is an

important need of the community. An independent need is the development of absolute standards for O<sub>2</sub>/N<sub>2</sub> calibration scales to the level of 5 per meg or better.

The relationship between changes in O<sub>2</sub>/N<sub>2</sub> ratio and equivalent changes in O<sub>2</sub> mole fraction has been discussed in peer-reviewed literature. However, confusion does still exist. Adding 1 µmol of O<sub>2</sub> per mole of dry air increases the O<sub>2</sub>/N<sub>2</sub> ratio by 4.77 per meg, which establishes an equivalency of 4.77 per meg per ppm (Keeling et al., 1998). The confusion arises because the increase in mole fraction of O<sub>2</sub> caused by this addition is not 1 ppm, but rather 0.79 ppm. The increase in mole fraction is smaller than 1 ppm because the total number of moles has also increased. For a trace gas, in contrast, adding 1 µmol/mol of dry air increases the mole fraction by almost exactly 1 ppm. The factor 4.77 per meg per ppm relates the change in O<sub>2</sub>/N<sub>2</sub> ratio to the equivalent uptake, emission, or change in a trace gas, and is thus the relevant factor for most applications, e.g. estimating changes in O<sub>2</sub>/N<sub>2</sub> ratios in an air parcel corresponding to a photosynthetic or respiratory flux of CO<sub>2</sub>, or calculating changes in O<sub>2</sub>/N<sub>2</sub> ratios resulting from O<sub>2</sub> fluxes in a model that does not account for changes in the total number of moles. The alternative factor of  $4.77/0.79 = 6.04$  per meg per ppm can also be relevant in certain applications, however, such as calculating instrument response functions (Kozlova et al., 2008, p. 4).

## 5.2 Current O<sub>2</sub>/N<sub>2</sub> calibration and comparison activities

At the 12<sup>th</sup> WMO/IAEA Meeting in Toronto (GGMT-2003, WMO/GAW Report No. 161, 2005) the GOLLUM programme was initiated to provide constraints on the offsets between the different laboratory scales and to clarify the requirements for placing measurements on a common scale. There are two components to this programme, each of which has been running since 2005: a “sausage flasks” comparison programme, and a “round-robin cylinder” comparison programme. The sausage flask programme compares the laboratories’ ability to extract and analyse air from a small flask sample, whereas the round-robin cylinder programme compares the laboratories’ calibration scales, and their methods for extracting and analysing air from high-pressure gas cylinders.

Details of the GOLLUM programme can be found in WMO/GAW Report No. 161 (2005) and at a dedicated web site: <http://gollum.uea.ac.uk/>. The programme is coordinated by A. Manning at the University of East Anglia (UEA), with the laboratory of R. Keeling at Scripps Institution of Oceanography (SIO) serving as the point of origin for the round-robin programme and the hub for the sausage-flask programme.

The repeated round-robin cylinder analyses at SIO showed the change in the cylinders was zero to within ±3 per meg, the estimated precision of a trend measurement in the SIO laboratory. All results are available to participants in detail on the web site.

In addition to preparing cylinders for the GOLLUM programme, the Keeling laboratory at SIO has been preparing high-pressure cylinders for a number of laboratories. These cylinders have provided another means to assess laboratory scale differences and may assist in developing a common scale.

**5.3 Recommendations for O<sub>2</sub>/N<sub>2</sub> calibration and comparison activities**

- a) Continue both, the round-robin cylinder and sausage flask components of the GOLLUM programme for the indefinite future.
  - b) Expand the round-robin cylinder programme to include:
    - An additional suite of circulating cylinders equipped with "dip-tubes" to minimize influence of thermal fractionation.
    - An additional suite of circulating cylinders that incorporates those field stations making in- situ measurements of atmospheric O<sub>2</sub> and which are not presently included in any O<sub>2</sub> comparison programme.
  - c) Sustain the web page for logistical support and for rapid dissemination of results of the GOLLUM programme. Expand the web page by adding results of the sausage flask programme.
  - d) Encourage the timely delivery of comparison results by all participants.
  - e) Encourage SIO to continue to provide reference gases to laboratories on request at reasonable cost.
  - f) Encourage additional comparison efforts, such as overlapping flask sampling from different programmes, to compare O<sub>2</sub>/N<sub>2</sub> scales and methods between programmes.
  - g) Encourage the standardisation of existing O<sub>2</sub>/N<sub>2</sub> techniques, and particularly to identify and correct weaknesses in laboratories' current techniques in sample collection, sample analysis, and in defining and propagating calibration scales.
  - h) Encourage laboratories to carry out further research into known issues in O<sub>2</sub> measurement such as developing intake and 'tee' designs that do not fractionate O<sub>2</sub> relative to N<sub>2</sub>, and to investigate the influence of dip-tubes installed in high pressure cylinders
  - i) It is recommended that an effort be undertaken to produce gravimetric standards for O<sub>2</sub>/N<sub>2</sub> to solidify the long-term calibration of O<sub>2</sub>/N<sub>2</sub> measurements.
  - j) Encourage efforts by the relevant laboratories to assess the influence on their O<sub>2</sub>/N<sub>2</sub> measurements (using different analytical techniques) of variations in CO, H<sub>2</sub>, CH<sub>4</sub>, N<sub>2</sub>O, H<sub>2</sub>O, and any other species that are commonly present in air samples with the potential to interfere at the per meg level.
  - k) Produce a list of 'best practices' for flask sample collection for subsequent O<sub>2</sub> analysis.
-

## 6. SPECIFIC REQUIREMENTS FOR CH<sub>4</sub> CALIBRATION

### 6.1 Background

NOAA/ESRL serves as the WMO/GAW Central Calibration Laboratory (CCL) for methane. In 2015 the scale was expanded and a new calibration scheme was implemented. All historical calibrations have been updated. For details see [http://www.esrl.noaa.gov/gmd/ccl/ch4\\_scale.html](http://www.esrl.noaa.gov/gmd/ccl/ch4_scale.html). The current (June 2016) version of the WMO mole fraction scale for methane is WMO CH<sub>4</sub> X2004A. The calibration scale consists of 22 gravimetrically prepared primary standards which cover the nominal range of 300 to 5900 ppb, so it is suitable to calibrate standards for measurements of air extracted from ice cores and contemporary measurements from GAW sites. The range of secondary transfer standards is nominally 390 to 5000 ppb.

### 6.2 Recommendations for CH<sub>4</sub> calibration and comparison activities

- a) The CCL will transfer the CH<sub>4</sub> scale to calibrated CH<sub>4</sub>-in-dry-air standards with an uncertainty of <2 ppb (95% confidence level, coverage factor k=2).
  - b) The CCL should routinely assess its ability to transfer the scale using the new multipoint calibration strategy.
  - c) All laboratories that participate in the GAW Programme must calibrate measurements relative to the WMO CH<sub>4</sub>-in-dry-air mole fraction scale and report them to the WMO/GAW World Data Centre for Greenhouse Gases in Japan.
  - d) Each GAW measurement laboratory or Network Calibration Centre of GAW partners must actively maintain its link to the WMO Scale by having its highest level standards for CH<sub>4</sub> re-calibrated by the CCL every six years. Each laboratory should also participate in WMO round-robin comparisons of working standards and in regional comparisons.
-

## 7. SPECIFIC REQUIREMENTS FOR N<sub>2</sub>O CALIBRATION

### 7.1 Background

Measurements of nitrous oxide made by GAW partners are used to better understand the sources and sinks of this greenhouse gas. While measurement compatibility is improving, systematic differences among N<sub>2</sub>O mole fractions reported by different laboratories are still large compared to atmospheric gradients. The mean inter-hemispheric difference in N<sub>2</sub>O mole fraction is around 1 ppb and the pole-to-pole difference is 2 ppb. These differences are 0.3-0.6% of the recent global mean mole fraction of N<sub>2</sub>O in the troposphere. This necessitates not only high measurement precision, but also high consistency among assigned values for standards. Compatibility of measurements from different laboratories of 0.1 ppb is needed.

NOAA/ESRL serves as the CCL for nitrous oxide. The current (June 2016) version of the WMO mole fraction scale for nitrous oxide is WMO N<sub>2</sub>O X2006A. The scale consists of 13 gravimetrically-prepared N<sub>2</sub>O-in-dry-air Primary Standards covering the range of 260–370 ppb (Hall et al., 2007). The reproducibility of NOAA N<sub>2</sub>O calibrations is estimated to be 0.2 ppb at the 95% confidence level.

### 7.2 Recommendations for N<sub>2</sub>O calibration and comparison activities

- a) Each GAW measurement laboratory or network calibration centre of GAW partners must actively maintain its link to the WMO Scale by having a subset of its highest level standards for N<sub>2</sub>O re-calibrated by the CCL every four years.
  - b) The CCL and the WCC (Karlsruhe Institute of Technology, Institute for Meteorology and Climate Research) should work together to establish more frequent comparisons among GAW stations and other key laboratories that measure N<sub>2</sub>O. Given the difficulties involved in N<sub>2</sub>O measurement, the frequency of current round-robin activities is insufficient for quality control purposes.
  - c) The use of a travelling N<sub>2</sub>O instrument during e.g. audits by the WCC-N<sub>2</sub>O is encouraged. Parallel measurements should be made using an independent sampling system whenever feasible.
  - d) The CCL should begin development of new primary standards to address minor mole fraction dependent bias observed in X2006A. New standards should have suitable isotopic composition and matrix for use with spectroscopic methods.
  - e) The expert community should explore the use of alternative analytical methods, compare them to current ECD techniques and share the finding with GGMT.
  - f) The CCL should investigate observed divergence from the Advanced Global Atmospheric Gases Experiment (AGAGE) N<sub>2</sub>O scale.
-



## 8. SPECIFIC REQUIREMENTS FOR SF<sub>6</sub> CALIBRATION

### 8.1 Background

Sulphur hexafluoride (SF<sub>6</sub>) is a very long-lived trace gas with strong infrared absorbance. SF<sub>6</sub> is 23900 times more effective as a climate forcing agent than CO<sub>2</sub> on a per-mass basis over a 100-year time scale. The tropospheric mole fraction of SF<sub>6</sub> has increased steadily, with a growth rate of 0.2-0.3 ppt yr<sup>-1</sup>. The steady growth rate, long lifetime (>600 years), and low solubility in water make it a useful tracer of atmospheric transport, including stratospheric "age-of-air determination".

SF<sub>6</sub> is typically measured using gas chromatography with electron capture detection (GC-ECD), similar to N<sub>2</sub>O. NOAA/ESRL serves as the WMO/GAW Central Calibration Laboratory (CCL) for atmospheric SF<sub>6</sub>. The current (June 2016) version of the WMO mole fraction scale for sulphur hexafluoride is WMO SF<sub>6</sub> X2014. The scale is defined by 17 primary standards over the range 2-20 ppt.

The Korean Meteorological Administration (KMA), assisted by Korea Research Institute of Standards and Science (KRISS), serves as a World Calibration Centre for SF<sub>6</sub>. A first SF<sub>6</sub> comparison was initiated by KMA in 2016 (<http://www.wmo.int/pages/prog/arep/gaw/documents/SICE-2016.pdf>).

### 8.2 Recommendations for SF<sub>6</sub> calibration and comparison activities

- a) Investigations are encouraged to explore advanced techniques to improve measurement precision.
  - b) KMA is encouraged to organize round-robin comparisons of SF<sub>6</sub> working standards between WMO participants.
-

## 9. SPECIFIC REQUIREMENTS FOR CO CALIBRATION

### 9.1 Background

CO is an important component in tropospheric chemistry due to its high reactivity with OH. It is the major chemically active trace gas resulting from biomass burning and fossil fuel combustion, and a precursor gas of tropospheric ozone. Atmospheric measurements are made on collected air samples or by in situ analysis, as well as systematic measurements from satellites, aircrafts and surface-based FTIRs. Remote sensing by spectroscopic retrieval of CO principally provides column abundances; wide geographical coverage of CO with some limited vertical resolution. These data are becoming available from ground-based remote sensing as well as several satellite-based sensors (MOPITT-TERRA (Measurement Of Pollution in The Troposphere), TES-AURA (Tropospheric Emission Spectrometer aboard AURA satellite), AIRS (Atmospheric Infrared Sounder)-AQUA, GOSAT (Greenhouse gases Observing SATellite). The TCCON network of ground-based remote-sensing instruments provides total column information. Differences among reference scales and drift of standards have been a serious problem for those in situ CO measurements in the past. The present recommendations, however, pertain to the calibration of in situ observation only; the validation of remote sensing data is a separate issue not addressed here.

### 9.2 Current CO calibration and comparison activities

NOAA ESRL is the WMO/GAW CCL for carbon monoxide. Due to the lack of stability of CO in high pressure cylinders, the CO scale has historically been defined by repeated sets of gravimetric standards. Secondary standards calibrated versus multiple sets of gravimetric standards have been used to ensure consistency across the gravimetric sets. Gravimetric standards that define the scale were made in 1996/1997, 1999/2000, 2006, and 2011. The CCL has made revisions of the CO scale each time new gravimetric standard sets have indicated significant drift in the scale. Scale revisions are indicated by name (WMO CO X2000, WMO CO X2004, and WMO CO X2014).

The latest scale revision (WMO CO X2014A, introduced in December 2015) reflects a decision by the CCL to change the method used to define the scale with the goal of simplifying the definition of the scale and improving the ability to track drift of the standards that define the scale. The 2011 gravimetric standards have been designated as the Primary Standards and all measurements are related to their values in a strict hierarchical calibration scheme. There are 14 primary standards covering the nominal range 30–1000 ppb. The primary standards are known to have growing CO. The drift rates in the primary standards are measured by regular comparisons of the primary standards to a suite of static dilutions (termed dilution standards) of three very high mole fraction gravimetric mixtures of CO ( $\sim 0.1$  to  $0.9\%$ ) and CH<sub>4</sub> ( $\sim 3\%$ ) in air. Potential rates of CO growth in these percent level mixtures (termed parent tanks) is assumed to be insignificant relative to their mole fractions giving a known and stable CO to CH<sub>4</sub> ratio. CH<sub>4</sub> is measured in each dilution standard and used with the known CO:CH<sub>4</sub> ratio of the parent to assign a CO value to the dilution standard. Over time, drift in the primary standards is determined from repeated comparisons to new sets of dilution standards made

from the stable parent tanks. (See CCL website for more detailed information [http://www.esrl.noaa.gov/gmd/ccl/co\\_scale.html](http://www.esrl.noaa.gov/gmd/ccl/co_scale.html)).

The CCL has organized round robin comparisons with several GAW laboratories. These have exposed a number of measurement problems including the application of the analytical technique, the calibration approach, drift of reference gases and uncertainties in the reference scale. Empa, as WCC for CO, has developed an audit system for CO measurements at GAW stations. This has helped the international in situ CO measurement community enormously, but also exposed some drift and inconsistency in the NOAA/ESRL calibration scale, as well as in the gravimetric technique.

### **9.3 Recommendations for CO calibration at the WMO/GAW CCL and at GAW stations**

- a) The CCL shall aim to propagate the CO scale to  $\pm 1$  ppb or 0.5% (whichever is greater, expanded uncertainty,  $k=2$ ). All GAW participants should use standards traceable to the WMO CO X2014A or a subsequently revised version of the WMO scale.
  - b) The CCL should maintain one set of standards that defines the WMO scale (see Section 1.2a of these recommendations).
  - c) The CCL should maintain a strict hierarchy of standards. All intermediate levels of reference standards (secondaries, tertiaries) that are part of this hierarchical calibration chain should be reassigned relative to the scale at appropriate intervals to assure calibration consistency over time. Multiple methods should be used to ensure the CO mole fractions in primary standards are not changing, or are tracked.
  - d) The CCL is responsible for documenting the evolution of the WMO CO scale and for communicating all revisions. This documentation should involve disclosure of the development of mole fractions in the individual primary standards that define the scale and procedure for their measurement.
  - e) The replacement of the gas chromatographic technique with HgO reduction and photometric detection at the CCL with a spectroscopic technique has resulted in significant improvements of the consistency of CO calibrations. It is strongly recommended that standards that have been calibrated by the CCL before the implementation of the laser-spectroscopic technique are recalibrated. Based on recent assessments of standard drifts a recalibration interval of three years for station standards is recommended.
  - f) Growth of CO in high pressure cylinders is a known issue. Laboratories are encouraged to develop techniques to monitor cylinders for drift. If drift is suspected in the laboratories highest level standards, then they should be returned to the CCL for recalibration to maintain traceability.
-

## 10. SPECIFIC REQUIREMENTS FOR H<sub>2</sub> CALIBRATION

### 10.1 Background

Molecular hydrogen plays a significant role in global atmospheric chemistry due to its role in CH<sub>4</sub> – CO - OH cycling. Therefore, it is important to establish its global budget and atmospheric trend. There is a clear need to get compatible data from independent networks and therefore the propagation of the WMO scale for the GAW network remains a task of high priority. Molecular hydrogen is recognized as an important target variable to be measured in the WMO/GAW global network and specific tasks are outlined for implementation by the global research community (WMO/GAW Report No.197, 2011).

### 10.2 Current H<sub>2</sub> calibration and comparison activities

MPI-BGC serves as the WMO/GAW CCL for atmospheric molecular hydrogen. The current scale is WMO H<sub>2</sub> X2009 It has been embodied in a set of 13 primary standards of hydrogen in air ranging from 140 to 1200 ppb (Jordan and Steinberg, 2011). In 2013, H<sub>2</sub> growth in two of the primary standards (at 415 ppb and 850 ppb, respectively) was detected. Two alternative standards that had been prepared as part of a secondary (scale back-up) set with similar H<sub>2</sub> mole fractions have replaced these drifting standards. These replacement standards have been analysed since 2010, thus the calibration record can be revised back to 2010. Recently increases in hydrogen at rates of 0.3 ppb/year have been detected in two additional primary standards and evidence suggests others may be increasing at < 0.1 ppb/year. Based on this evidence and experimental results suggesting a mole fraction related bias in the scale of about 2 ppb in the atmospheric range a revision of the WMO scale will be made in 2016.

### 10.3 Recommendations for H<sub>2</sub> calibration and comparison activities

- a) It is recommended that the CCL bi-annually produces additional standards that provide a check for the stability of the WMO scale.
- b) Long time series of atmospheric hydrogen have been generated by the NOAA and CSIRO (Commonwealth Scientific and Industrial Research Organisation)/AGAGE monitoring networks. To enable a collaborative global network for hydrogen measurements the measurement groups are encouraged to establish traceability to the new WMO scale.
- c) In addition, time-dependent biases between laboratories that have not always been related to scale changes, underline the necessity to continue comparison of hydrogen data. These exercises will be a valuable tool to monitor the compatibility of the measurements and shall be continued at regular intervals.
- d) A major problem encountered by most laboratories that measure hydrogen is the stability of their standards. Aluminium cylinders commonly used for other trace gas standard mixtures often show significant growth of hydrogen. Therefore, it is recommended that every laboratory develop a strategy to account for this. To minimize the risk of drift the highest level standard gas containers of any

laboratory should preferably be made of stainless steel. A recalibration by the CCL after two years is recommended.

- e) Appropriate characterization of the detector response in the ambient range is required given the strong non-linear response of the commonly used HgO reduction detectors. Analysis techniques with characteristics (i.e. precision and non-linearity) superior to the common HgO reduction detectors have been described recently (Novelli et al., 2009) and should be considered for new installations.
  - f) Due to the strong non-linearity of the HgO reduction detectors it is particularly important for H<sub>2</sub> measurements that the mole fraction of the working standard gas is close to the mean annual H<sub>2</sub> level observed at the site. In contrast, the target standard gases used for quality control purpose are recommended to have H<sub>2</sub> mole fractions that are at the high end of the observed values to provide good diagnostic information.
-

## 11. RECOMMENDATIONS FOR GREENHOUSE GAS NETWORKS IN AREAS OF HIGH DENSITY EMISSIONS

Recent studies have strived to improve the understanding of spatial and temporal scale in greenhouse emissions beyond what is possible from a global background network, leading to greenhouse gas measurements in areas of high density emissions. Quantification of regional emissions using atmospheric observations is the subject of ongoing research, and recommendations will likely evolve as methods mature. Some differences from the requirements of global background measurements are already clear, however. Instrument calibration and operation strategies should account for the typically elevated and often highly variable signals in such areas. Characterizing the spatial variability of the emissions in these areas will often require multiple measurement sites in a regional network configuration. Site selection in regional networks should include consideration of the footprint of each sampling location such that the combined footprints of the regional network sites reasonably represent the region. Compatibility between instruments within a regional network is necessary over the often large measurement ranges. Of central importance is the ability to quantify the local excesses in GHG concentration relative to the local boundary condition of the study area, which may differ from the global baseline. This requires methods for establishing the relevant local boundary condition (from surrounding global baseline or regional measurements) as well as the accurate measurements of the enhancements caused by the regional emissions.

The required accuracy of high-density emissions area measurements is a function of the magnitude of the enhancement, with higher accuracy required where the local GHG excess is small. Requirements for small GHG excess values should be comparable to WMO background requirements. For elevated measurements we recommend an absolute accuracy of 5% or better for the excess over the local boundary condition. At this level, measurement uncertainties will be small relative to other sources of uncertainty in calculated fluxes based on imperfect knowledge of atmospheric transport. If enhancements are large, the requirement of 5% accuracy will require reference standards over a much wider range than for background measurements that are compatible with the WMO scales near ambient values. Thus we recommend that high-density emissions area measurements still adhere to WMO guidelines for mole fractions that are near background levels, but we recognize that compatibility requirements for elevated measurements are far less stringent.

$\Delta^{14}\text{C}$  in  $\text{CO}_2$  represents a special case where reproducibility of 30-50% for individual measurements of the regional  $\Delta^{14}\text{C}$  offset from the local boundary condition may be sufficient to be useful, although precision of 5% or better is ultimately desirable.

### Recommendations

- 1) We recommend a working group for urban greenhouse gas emissions that interacts with the WMO/GAW Urban Research Meteorology and Environment Project. Regional measurement networks should include local boundary condition measurements.
- 2) Regional networks should have an absolute accuracy of 5% or better for the excess over the local boundary condition, with the exception of  $\Delta^{14}\text{C}$  for which reproducibility of 30-50% over the local boundary condition may be sufficient.

## 12. RECOMMENDATIONS FOR GROUND-BASED REMOTE SENSING TECHNIQUES

The Total Carbon Column Observing Network (TCCON) was accepted into the GAW network following the 15<sup>th</sup> GGMT meeting in 2009. TCCON is a ground-based network of Fourier Transform Spectrometers which measure high resolution direct beam solar absorption spectra in the near infrared. Total column amounts of trace gases are inferred from the measured spectra using standardized retrieval procedures. Column average dry air mole fractions are determined by dividing the trace gas total column by the total dry air column derived from the simultaneous retrieval of the total column of O<sub>2</sub>. The measured water vapour column is also obtained from the solar spectrum.

TCCON measurements are subject to strict controls on instrumentation and data analysis set out in the TCCON data policy (<https://tcon-wiki.caltech.edu/>). Adherence to these controls is a necessary condition to contribute to the TCCON database.

TCCON measurements must be linked to WMO mole fraction scales. TCCON total column amounts are validated by simultaneous determination of the partial vertical column amount of relevant trace gases by in situ measurements during aircraft overflights or by other techniques such as near-total column direct air samples (AirCore) obtained near the location of a TCCON instrument, and measured upon landing by WMO-scale calibrated instruments.

### **Recommendation**

Ground-based remote sensing measurements of CO<sub>2</sub>, CH<sub>4</sub>, N<sub>2</sub>O and CO must follow the formal TCCON data protocols and be accepted in the TCCON network to be acceptable to GAW.

---

## 13. RECOMMENDATIONS FOR AIR MEASUREMENTS OF CO<sub>2</sub> ON SHIPS

### 13.1 Background

Measurement of the partial pressure of CO<sub>2</sub> (pCO<sub>2</sub>) throughout the global oceans is an important constraint on the role that oceans play in absorbing anthropogenic CO<sub>2</sub> that has been released into the atmosphere. These measurements are being made on a combination of research ships and ships of opportunity that, in most cases, also have the ability to make measurements of atmospheric CO<sub>2</sub>. In the event that these air measurements meet the basic requirements of the GGMT, the more than 250 transects of ships that contribute to the global ocean pCO<sub>2</sub> database (Surface Ocean CO<sub>2</sub> Atlas – SOCAT, <http://ferret.pmel.noaa.gov/erddap/tabledap>) will provide a valuable boundary condition for studies that are focused on constraining continental fluxes.

On Wednesday September 16, 2015 a break out session was convened as part of the GGMT-2015 meeting to discuss the benefit, measurement requirements and path forward for making measurements of atmospheric CO<sub>2</sub> that could become part of the global cooperative network of greenhouse gas measurements. As part of this discussion, the role of the GGMT in helping to verify the repeatability of the surface ocean pCO<sub>2</sub> measurement was also discussed.

### 13.2 Recommendations

#### 1) Benefits

It was felt that the atmospheric CO<sub>2</sub> community would benefit from atmospheric measurements of CO<sub>2</sub> over oceans because ocean measurements would provide a valuable boundary condition for inversion models focused on constraining continental-scale fluxes. Because of the potential increase in number of observations and the complexity of CO<sub>2</sub> land-based emissions in the northern subtropical regions, this region would benefit the most. It was also pointed out that ocean community would benefit in several ways. The most significant constraint would be for making ocean flux estimates in coastal regions based on the measurements of the air-sea CO<sub>2</sub> gradient where the typically used Co-operative Atmospheric Data Integration Project (GlobalView) estimates of atmospheric CO<sub>2</sub> can lead to significant biases. It turns out that, based on analysis of the difference between NOAA's CarbonTracker and NOAA's GlobalView product, these differences may also lead to biases of the ocean basin scale estimates because of the lack of east-west gradients in NOAA's GlobalView product. It was also felt that an improvement in the quality control of atmospheric measurements on ships would likely improve the traceability of oceanic measurements of pCO<sub>2</sub> to CCLs.

#### 2) Measurement requirements

Other than stack gas contamination, high humidity conditions and potential inlet contamination issues related to sea salt build up, the approach to making measurements traceable to CCLs is similar to other land-based in situ CO<sub>2</sub>



measurements discussed in this document. These include a set of standards that are clearly traceable to the WMO CO<sub>2</sub> X2007 scale; span the expected range of atmospheric values; are numerous enough in concentration-space and spacing between measurements to account for non-linearities and drift of the CO<sub>2</sub> analysis system, respectively. A well-defined plan will also be needed to filter out contamination from the ship's exhaust system so that local ship emissions do not bias the measurements. It also will be necessary to test ways to independently verify that inlet lines and procedures for deriving the dry mole fraction of CO<sub>2</sub> are not biasing the final data product. These approaches will vary depending on which CO<sub>2</sub> analyser is used and on the methods used to correct for humidity in the sample stream.

3) **Next steps for implementation**

- a) Ensure that ocean community is interested in providing atmospheric CO<sub>2</sub> measurements at the level required for atmospheric CO<sub>2</sub>. (Not expected to be a problem)
  - b) Invite ocean community representatives to next GGMT for further input.
  - c) Promote discussion of opportunity for collaboration between ocean and atmospheric investigators at the next International Carbon Dioxide Conference in 2017.
  - d) Define requirements for compatibility, traceability and precision of atmospheric measurements from research ships and ships of opportunity.
  - e) Quantify potential impact of ocean-based atmospheric measurements using with an Observing System Simulation Experiment (OSSE).
  - f) Design an independent analyser system that can be deployed for single transect comparisons to verify lack of systematic bias of measurements on ships.
    - i. Needs to be compact and easily installed.
    - ii. Relatively stable (low drift and sensitivity to environmental conditions like temperature and pressure) and easy to operate
    - iii. Ideally, would include a separate inlet system.
  - g) Provide a resource (guide) to improve reproducibility and traceability for atmospheric and ocean measurements of CO<sub>2</sub> dry mole fraction.
  - h) Initiate collaboration starting with deployment of independent measurement system on research ships with investigators who are also managing ocean measurements on ships of opportunity to establish a protocol for measurement comparison.
-

## **14. RECOMMENDATIONS FOR DATA MANAGEMENT, ARCHIVING, AND DISTRIBUTION**

### **14.1 Data management**

All GAW measurement laboratories regardless of programme size are required to manage all new and existing atmospheric trace gas and isotope data and supporting metadata using a database management strategy (DBMS) that meets or exceeds the following criteria:

- a) Demonstrate that mole fractions and isotope ratios can be unambiguously and automatically reproduced, also retrospectively, from raw data at any time in the future.
- b) Demonstrate that revisions to a laboratory's internal calibration scale or to the WMO scale can be efficiently and unambiguously propagated throughout the database.
- c) Support routine and automatic database updates of all measurements and metadata.
- d) Ensure that all data reside locally, in a single location, and are centrally accessible to internal users.
- e) Ensure fast and efficient retrieval of all data.
- f) Maximise users' ability to assess data quality.
- g) Facilitate data and metadata exploration.
- h) Minimise the risk of data loss or corruption due to theft, misuse, or hardware/software failure.
- i) Maximise security of primary data (e.g. data from which all processed data is derived).
- j) Support routine and automatic backup of all data.
- k) Support complete data recovery in the event of catastrophic data loss.

GAW measurement laboratories are encouraged to use WMO/GAW Report No. 150 as a guideline in developing and implementing an atmospheric data management strategy.

Laboratories with demonstrated expertise in data management are encouraged to share their expertise. Table 2 lists those in the WMO/GAW community who have offered to share their expertise. The area of expertise described in the table is general; interested researchers are encouraged to e-mail the contact person directly for more detail.

### **14.2 Data archiving**

- a) Laboratories participating in the WMO/GAW Programme must submit their data to the World Data Centre for Greenhouse Gases (WDCGG) (according to GAW Implementation Plan for the period 2016-2023). A co-ordinated annual submission of data before the end of August of the following year, with clearly identified version number of submitted data and calibration scale, as well as supporting details is strongly recommended for data inclusion in the WMO Annual Greenhouse

Gas Bulletin. The data obtained in a regional or other national or cooperative network should be submitted through the network centre responsible for data evaluation and archiving. The same recommendation holds to other public-access data archive centres.

- b) The revised WDCGG Data Submission and Dissemination Guide (WMO/GAW Report No. 188, 2009) includes data categories, data submission formats, data submission procedures, and ways of distributing data and products. Adherence to this guide is requested.
- c) The WDCGG distributes data in the current version and keeps old versions. To enhance the value of archived data, the WDCGG is encouraged to develop a system of flags for archived data, based on metadata for the measurements, instrument type, precision of measurements, results of comparison activities, and types of comparison activities engaged in collecting data. The SAG GHG should consider working with WDCGG in developing the flags and encouraging contributing groups to provide the additional information needed.
- d) The WDCGG will establish a data user group with the help of Sander Houweling to provide guidance on ways to improve the useability of data distributed by the WDCGG.
- e) This community will continue to develop best practices designed to standardize the reporting of the various components of measurement uncertainty, metadata, and quality control information such as data flags, keeping in mind the needs of both data providers and users.

At this meeting, attendees were made aware of the plan to transfer reactive gas data from WDCGG to the newly-established WDCRG at NILU, and a request from WMO/GAW SAG-RG to include CO data in this plan. The majority of GGMT attendees strongly oppose the transfer of CO data to WDCRG because CO observations are made by many of the same laboratories contributing CO<sub>2</sub>, CH<sub>4</sub>, and other greenhouse gas records to the WDCGG. Contributing data and metadata to two or more WDCs would be an additional burden to providers and introduce the potential for inconsistencies in metadata. In addition, several laboratories are making a suite of measurements including VOCs, halogenated compounds, and greenhouse gases on the same atmospheric air sample. Archiving and distributing measurements from the same sample from different WDCs is strongly opposed by GGMT attendees. The current situation regarding CO (as of June 2016) is that WDCGG will continue its efforts toward archiving of the long-lived greenhouse gas observational data and will remain the primary archive for Carbon Monoxide (CO) data (a reactive gas by definition, but of key importance in relation to carbon cycle interpretations). There was general agreement that it would be extremely valuable to researchers if GAW data were readily available from any of the WDCs. Thus, the GGMT attendees strongly recommend that the GAW Expert Team on World Data Centres (ET-WDCs) explore ways in which GAW data can still be archived at the appropriate WDC but discoverable and accessible from any WDC. ET-WDCs can consider GAW Station Information System (GAWSIS) as a potential hub for ensuring seamless data access to the GAW WDC and archiving centres of the contributing networks.

**Table 2. WMO GAW members who have offered to share expertise**

<i>Name</i>	<i>Contact Email</i>	<i>Lab</i>	<i>Location</i>	<i>Area of Expertise</i>
<i>WDCGG</i>	wueno@met.kishou.go.jp	JMA	Japan	Data management in WDCGG
<i>Lynn Hazan</i>	lynn.hazan@lsce.ipsl.fr	LSCE	France	Data management
<i>Paul Krummel</i>	paul.krummel@csiro.au	CSIRO	Australia	Quality control, non-CO <sub>2</sub> scale conversions, inter-comparisons
<i>NOAA data team</i>	john.mund@noaa.gov	NOAA	United States	Data management, quality control, scale conversion
<i>Ludwig Ries</i>	ludwig.ries@uba.de	UBA	Germany	Data acquisition, management and quality control. Software solutions available for data acquisition, instrument control, calibration processing, interactive data preparation and validation.
<i>Martin Steinbacher</i>	martin.steinbacher@empa.ch	Empa	Switzerland	Data acquisition and processing with commercially available and custom-built software
<i>Doug Worthy</i>	Doug.worthy@ec.gc.ca	EC	Canada	Near real-time data processing via GC, NDIR, and CRDS technologies

### 14.3 Co-operative data products

All laboratories making high-quality greenhouse gases measurements are strongly encouraged to participate in cooperative data projects. Value-added products such as GLOBALVIEW enhance the value of any one individual measurement record by including it in a much larger cooperative network of observations.

Historically, NOAA has prepared comprehensive cooperative data products (e.g. GLOBALVIEW) using measurements made by GAW and non-GAW laboratories. It is likely more laboratories will begin to prepare and distribute smaller complementary data products including data from one or a few measurement groups. Products are complementary if their content and structure are fully compatible, data are prepared in a consistent and unambiguous manner; and no two products include the same original data. To ensure complementary products are fully compatible and easily accessible to users, this community will establish a working group tasked with recommending compatibility standards and best practices to maximize the likelihood of full compatibility among products made by different laboratories.

#### **14.4 Data distribution**

This community recognizes the need to develop new strategies to improve communication between data providers and data users. The WDCGG and its contributors will work together to explore ways in which this can be achieved including user registration prior to data access and persistent digital identifiers (e.g. Digital Object Identifier (DOI)). NOAA has already done considerable work in this area, which is described in Masarie et al., 2014; (<http://dx.doi.org/10.5194/essd-6-375-2014>). We strongly encourage both data contributors and data users to commit themselves to providing feedback during this development to ensure the needs of all are considered.

---

## 15. RECOMMENDATIONS FOR THE COOPERATIVE WMO/GAW NETWORK

The 17<sup>th</sup> World Meteorological Congress took place in Geneva, Switzerland on 25 May to 12 June 2015. Congress decided on the strategic priorities of WMO for the period 2016-2019. In its report Congress stressed the importance of the greenhouse gas observations and adopted a resolution on an Integrated Global Greenhouse Gas Information System.

In particular the Congress noted:

*"4.3(4).11 Congress noted the ongoing development of the Implementation Plan for an Integrated Global Greenhouse Gas Information System (IG<sup>3</sup>IS) (see: <http://www.wmo.int/gaw>). Congress agreed that IG<sup>3</sup>IS can become an important science-based tool for independent quantification of GHG sources and sinks, both natural and anthropogenic, delivering actionable information to help Members understand and manage greenhouse gas budgets on enhanced temporal and spatial scales. Congress further noted that the implementation of IG<sup>3</sup>IS can provide new and innovative services in support of the Global Framework on Climate Services (GFCS). Congress urged Members to undertake efforts related to the development of observational networks and modelling tools in support of IG<sup>3</sup>IS. Congress requested Members to report by the next Congress on the efforts undertaken in this direction in individual countries and regions. To this end Congress adopted Resolution 4.3(4)/1 (Cg-17) – Integrated Global Greenhouse Gas Information System."*

*This resolution requires further developments of the greenhouse gas observational network and modelling tools. It states in particular.....Requests Members:*

- 1) To give all possible support to the development, improvement and modernization of networks for observations of greenhouse gases and co-emitted species;*
- 2) To carry out greenhouse gas observations in accordance with GAW quality assurance principles;*
- 3) To ensure submission of observational data as well as metadata to the dedicated WMO/GAW Data Centre as well as GAWSIS within the period of time required to support IG<sup>3</sup>IS as will be documented in the specification of requirements through WIGOS and its OSCAR/Requirements catalogue;*
- 4) To cooperate on development of modelling tools for inverse modelling and anthropogenic greenhouse gas flux attribution;*
- 5) To collaborate with organizations and institutions that address the carbon budget of biosphere and ocean."*

We, the Expert Group convened at GGMT-2015, recommend the following observational strategies:

- 1) Sustain, improve and increase the number of the stations with continuous in situ measurements in the boundary layer and in the troposphere by aircraft. The WMO/GAW community should make an effort to establish and sustain observations in under-sampled continents/areas. In addition, efforts should be made to expand aircraft flights over vegetated areas that are currently not sampled or under-sampled, with priority given to tropical South America, Africa, and South East Asia. Station twinning, partnership and collaboration programmes (like CATCOS (Capacity Building and Twinning for Climate Observing Systems) by MeteoSwiss) should be further encouraged.
- 2) Develop and implement long-term total column measurements of Greenhouse Gases at a number of sites within the WMO/GAW Programme and its partners, the Total Carbon Column Observing Network (TCCON), recognizing the need for satellite validation and modelling. Total column measurements should be compared to vertical profiles of calibrated in situ and calibrated full-column AirCore measurements on a regular basis.
- 3) WMO encourages a diversity of independent measurement methods and independent calibration methods that are consistent with the high standards for analytical measurement, quality control, transparency and traceability defined elsewhere in this document. The goal of this diversity is to assure that the global atmospheric measurement enterprise remains robust and less vulnerable to systematic or method-specific error. A key component of this diversity is the rigorous and frequent comparison of independent methods and standards.
- 4) Develop high-quality measurements of carbon cycle tracers that can be used to attribute natural fluxes to their controlling processes ( $^{13}\text{CO}_2$ ,  $\text{O}_2/\text{N}_2$ ,  $^{18}\text{OCO}$ , stable isotopes in  $\text{CH}_4$  and  $\text{CO}$ ), especially to quantify the recent fossil fuel component ( $^{14}\text{CO}_2$ ,  $\text{CO}$ ...) from  $\text{CO}_2$  variations caused by natural sources/sinks. Additional tracers such as hydrocarbons and halocarbons are also useful for attribution as well as some of their own contributions to radiative forcing. A collaboration with the reactive gases community in GAW should be established. Along these lines it is essential that detailed spatially and temporally resolved emissions inventories of fossil fuel  $\text{CO}_2$ ,  $\text{CH}_4$ , and  $\text{CO}$  are being developed and pursued.
- 5) Further collaboration should be established with the biosphere and the ocean communities to improve source/sink estimates. Ship based observations of both atmospheric and ocean dissolved GHG should be encouraged. The same traceability principle is recommended for the atmospheric GHG measurements above the ocean

using ship platforms as for the rest of the network. Laboratories measuring GHGs from ships are invited to take part in regular comparison taking place within the GAW network and are recommended to collect flasks to be analysed in the GAW labs to ensure compatibility of the ship based observations with continental sites.

- 6) Similarly, measurements of atmospheric composition at flux towers (e.g. Flux Canada, ICOS, Ameriflux) should be linked to WMO calibration scales. Investigators at key laboratories in these networks should be encouraged to take part in WMO Round Robin exercises and flask samples of air could be exchanged or comparative measurements could be made at key sites in these networks.
  - 7) To achieve the above goals, thorough quality control procedures are necessary to ensure that WMO/GAW data meets the recommended compatibility goals. Data that has not been quality controlled is of very limited value for the scientific community as well as for society.
  - 8) WMO encourages and facilitates the development of improved atmospheric tracer transport models [and data assimilation techniques]. Atmospheric observations should be used to quantify sources and sinks by means of improved inverse modelling on various spatial and temporal scales. Not only model parameterization improvements are important, but also the use of several independently developed models and their frequent comparison, contributes significantly to a more realistic assessment of the uncertainty of the inferred fluxes. Finally, it is important to develop and maintain community models that are numerically efficient and can run on standard computer platforms with a modest amount of training, and are made available to the entire scientific community.
  - 9) It is important that atmospheric measurement methods and high-resolution models be developed that can provide objective and transparent verification of emissions of CO<sub>2</sub> and other gases for regions with intensive emissions, such as urban areas and oil and gas fields.
-



## **16. ORGANIZATION OF GGMT-2017**

There was general agreement among all that it would be desirable to convene the next meeting, the 19<sup>th</sup> WMO/IAEA Meeting on Carbon Dioxide, Other Greenhouse Gases and Related Tracers Measurement Techniques, at Empa, Dübendorf, Switzerland. Dr Martin Steinbacher and Dr Christoph Zellweger have agreed to organize and host this meeting. The GGMT-2017 meeting will take place from 27 – 31 August 2017 back-to-back with 10th International Carbon Dioxide Conference (ICDC10), which will take place from 20–25 August 2017 at Interlaken, Switzerland.

---

## References

- Assonov S.S., C.A.M. Brenninkmeijer, 2003a: On the O-17 Correction for CO<sub>2</sub> Mass Spectrometric Isotopic Analysis, *Rapid Communications in Mass Spectrometry*, 17, 1007-1016.
- Assonov S.S., C.A.M. Brenninkmeijer, 2003b: A Redetermination of Absolute Values for R-17(VPDB-CO<sub>2</sub>) and R-17(VSMOW), *Rapid Communications in Mass Spectrometry*, 17, 1017-1029.
- De Bièvre, P., 2008: Essential for metrology in chemistry, but not yet achieved: truly internationally understood concepts and associated terms, *Metrologia* 45, 335-341.
- Brand, W.A., S.S. Assonov, and T.B. Coplen, 2010: "Correction for the O-17 interference in delta(C-13) measurements when analyzing CO<sub>2</sub> with stable isotope mass spectrometry (IUPAC Technical Report)," *Pure and Applied Chemistry*, Vol. 82, pp. 1719-1733.
- Brand, W.A., L. Huang, H. Mukai, A. Chivulescu, J. M. Richter and M. Rothe, 2009: "How well do we know VPDB? Variability of delta C-13 and delta O-18 in CO<sub>2</sub> generated from NBS19-calcite," *Rapid Communications in Mass Spectrometry*, 23, pp. 915-926, 2009.
- Coplen, T.B., W.A. Brand, M. Gehre, M. Groening, H.A.J. Meijer, B. Toman and R.M. Verkouteren, 2006: High Accuracy Measurements of Carbon Isotopic Reference Materials and Two-Point Anchoring of the VPDB Scale to Improve d<sup>13</sup>C Data, *Analytical Chemistry*, 78 (7), 2439 -2441.
- Coplen, T.B., 2011: Guidelines and recommended terms for expression of stable-isotope-ratio and gas-ratio measurement results, *Rapid Communications in Mass Spectrometry*, 25, 2538-2560.
- Dlugokencky, E.J., R.C. Myers, P.M. Lang, K.A. Masarie, A.M. Croswell, K.W. Thoning, B.D. Hall, J.W. Elkins and L.P. Steele, 2005: Conversion of NOAA CMDL Atmospheric Dry Air CH<sub>4</sub> Mole Fractions to a Gravimetrically Prepared Standard Scale, *Journal of Geophysical Research*, 110, D18306, doi:10.1029/2005JD006035.
- Ghosh, P., M. Patecki, M. Rothe and W.A. Brand, 2005: Calcite-CO<sub>2</sub> Mixed into CO<sub>2</sub>-Free Air: A New CO<sub>2</sub>-in-Air Stable Isotope Reference Material for the VPDB Scale, *Rapid Communications in Mass Spectrometry*, 19, 1097-1119.
- Graven, H.D., X. Xu, T.P. Guilderson, R.F. Keeling, S.E. Trumbore and S.C. Tyler, 2013: "Comparison of independent D14CO<sub>2</sub> records at Point Barrow, Alaska", *Radiocarbon*, 55(2-3), 1541-1545.

- GUM, 2008: Guide to the Expression of Uncertainty in Measurement, 1<sup>st</sup> edition, Joint Committee for Guides in Metrology (JCGM 100:2008), available at <http://www.bipm.org/en/publications/guides/>.
- Hall, B.D., G.S. Dutton and J.W. Elkins, 2007: The NOAA Nitrous Oxide standard Scale for Atmospheric Observations, *Journal of Geophysical Research*, 112, D09305, doi:10.1029/2006JD007954.
- Hammer, S., G. Konrad, A.T. Vermeulen, O. Laurent, M. Delmotte, A. Jordan, L. Hazan, S. Conil and I. Levin, 2013: Feasibility study of using a "travelling" CO<sub>2</sub> and CH<sub>4</sub> instrument to validate continuous in situ measurement stations, *Atmospheric Measurement Techniques*, 6, 1201-1216.
- ISO Guide 17025:2005, 2005: *General requirements for the competence of testing and calibration laboratories*, International Organization for Standardization, Geneva, Switzerland.
- ISO Guide 34:2009, 2009: *General requirements for the competence of reference material producers*, International Organization for Standardization, Geneva, Switzerland.
- ISO Guide 35:2006, 2006: Reference materials -- General and statistical principles for certification, International Organization for Standardization, Geneva, Switzerland. JQSRT (2009): *Journal of Quantitative Spectroscopy and Radiative Transfer*, 110, no.9-10, June/July 2009, Special issue on HITRAN.
- Jordan, A. and B. Steinberg, 2011: Calibration of atmospheric hydrogen measurements, *Atmospheric Measurement Techniques*, 4, 509–521, doi:10.5194/amt-4-509-2011
- Karion, A., C. Sweeney, P. Tans and T. Newberger, 2010: AirCore: An innovative atmospheric sampling system, *Journal of Atmospheric Oceanic Technology*, 27, 1839-1853, doi: 10.1175/2010JTECHA1448.1
- Keeling, R.F., A.C. Manning, E.M. McEvoy and S.R. Shertz, 1998: Methods for measuring changes in atmospheric O<sub>2</sub> concentration and their applications in southern hemisphere air, *Journal of Geophysical Research Atmospheres*, 103 (D3), 3381-3397, doi:10.1029/97JD02537.
- Kozlova, E.A., A.C. Manning, Y. Kisilyakhov, T. Seifert and M. Heimann, 2008: Seasonal, synoptic, and diurnal scale variability of biogeochemical trace gases and O<sub>2</sub> from a 300 m tall tower in central Siberia, *Global Biogeochemical Cycles*, 22 (4), doi:10.1029/2008GB003209.

- Lebegue, B., M. Schmidt, M. Ramonet, B. Wastine, C. Yver Kwok, O. Laurent, S. Belviso, A. Guemri, C. Philippon, J. Smith and S. Conil, 2016: Comparison of nitrous oxide (N<sub>2</sub>O) analyzers for high-precision measurements of atmospheric mole fractions, *Atmospheric Measurement Techniques*, 9, 1221-1238.
- Lehman, S.J., J.B. Miller, C. Wolak, J.R. Southon, P.P. Tans, S.A. Montzka, C. Sweeney, A.E. Andrews, B.W. LaFranchi, T.P. Guilderson and J.C. Turnbull, 2013: "Allocation of terrestrial carbon sources using <sup>14</sup>CO<sub>2</sub>: Methods, measurement, and modelling." *Radiocarbon*, 55(2-3), 1484-1495.
- Lowe, D.C., V. Levchenko, R.C. Moss, W. Allan, G. Brailsford and A.M. Smith, 2002: "Assessment of "storage correction" required for in situ <sup>14</sup>CO production in air sample cylinders," *Geophysical Research Letters*, 29(7): 1139.
- Masarie, K.A., R.L. Langenfelds, C.E. Allison, T.J. Conway, E.J. Dlugokencky, R.J. Francey, P.C. Novelli, L.P. Steele, P.P. Tans, B. Vaughn and J.W.C. White, 2001: NOAA/CSIRO Flask Air Intercomparison Experiment: A Strategy for Directly Assessing Consistency among Atmospheric Measurements Made by Independent Laboratories, *Journal of Geophysical Research*, 106, 20445-20464.
- Meijer, H. A. J., Neubert, R. E. M., and Visser, G. H. (2000): Cross contamination in dual inlet isotope ratio mass spectrometers, *International Journal of Mass Spectrometry*, 198 (1-2), 45-61.
- Miller, J.B., S.J. Lehman, C. Wolak, J.C. Turnbull, G. Dunn, H.D. Graven, R.F. Keeling, H.A.J. Meijer, A.T. Aerts-Bijma, S.W. Palstra, A.M. Smith, C.E. Allison, J.R. Southon, X. Xu, T. Nakazawa, S. Aoki, T. Nakamura, T.P. Guilderson, B.W. LaFranchi, H. Mukai, Y. Terao, M. Uchida and M. Kondo, 2013: "Initial results of an inter-comparison of AMS-based atmospheric <sup>14</sup>CO<sub>2</sub> measurements." *Radiocarbon*, 55(2-3), 1475-1483.
- Morgan, E.J., J.V. Lavrič, T. Seifert, T. Chicoine, A. Day, J. Gomez, R. Logan, J. Sack, T. Shuuya, E.G. Uushona, K. Vincent, U. Schultz, E.G. Brunke, C. Labuschagne, R.L. Thompson, S. Schmidt, A.C. Manning and M. Heimann, 2015: Continuous measurements of greenhouse gases and atmospheric oxygen at the Namib Desert Atmospheric Observatory, *Atmospheric Measurement Techniques*, 8, 2233-2250.
- Novelli, P.C., A.M. Crotwell and B.D. Hall, 2009: Application of Gas Chromatography with a Pulsed Discharge Helium Ionization Detector for Measurements of Molecular Hydrogen in the Atmosphere, *Environmental Science and Technology*, 43, 2431-2436.
- Rella, C.W., et al., 2013: High accuracy measurements of dry mole fractions of carbon dioxide and methane in humid air, *Atmospheric Measurement Techniques*, 6(3), 837-860.

- Scott, E.M., G.T. Cook and P. Naysmith, 2010: "A report of phase 2 of the fifth international radiocarbon intercomparison (VIRI)." *Radiocarbon*, 52(2-3): 846-858.
- Stuiver, M. and H. Polach, 1977: Discussion: Reporting of  $^{14}\text{C}$  data, *Radiocarbon*, 19, 355-363.
- Turnbull, J.C., H.D. Graven, J.B. Miller and S.J. Lehman, 2013: "Atmospheric radiocarbon workshop report." *Radiocarbon*, 55(2-3), 1470-1474.
- Tuzson, B., S. Henne, D. Brunner, M. Steinbacher, J. Mohn, B. Buchmann and L. Emmenegger, 2011: Continuous isotopic composition measurements of tropospheric  $\text{CO}_2$  at Jungfraujoch (3580 m a.s.l.), Switzerland: real-time observation of regional pollution events, *Atmospheric Chemistry and Physics*, 11, 1685-1696.
- Verkouteren R.M., C.E. Allison, S.A. Studley and K.J. Leckrone, 2003a: Isotopic metrology of carbon dioxide. I. Interlaboratory comparison and empirical modelling of inlet equilibration time, inlet pressure, and ion source conductance, *Rapid Communications in Mass Spectrometry*, 17(8), 771-776.
- Verkouteren R.M., S. Assonov, D.B. Klinedinst and W.A. Brand, 2003b: Isotopic metrology of carbon dioxide. II. Effects of ion source materials, conductance, emission, and accelerating voltage on dual-inlet cross contamination, *Rapid Communications in Mass Spectrometry*, 17(8), 777-782.
- VIM 3, 2008: International vocabulary of metrology. Basic and general concepts and associated terms, 3<sup>rd</sup> edition, Joint Committee for Guides in Metrology (JCGM 200:2012), available at <http://www.bipm.org/en/publications/guides/>.
- Vogel, F., J. Jeschka, B. Kromer, A. Steinhof, S. Hammer and I. Levin, 2011: A robust setup for long-term monitoring of fossil fuel  $\text{CO}_2$  and other trace gases, and its test against established conventional monitoring in Heidelberg. Expert Group Recommendations from the 15th WMO/IAEA Meeting of Experts on Carbon Dioxide, Other Greenhouse Gases and Related Tracer Measurement Techniques, Jena.
- Wendeberg M., J.M. Richter, M. Rothe and W.A. Brand, 2011: delta O-18 anchoring to VPDB: calcite digestion with O-18-adjusted ortho-phosphoric acid, *Rapid Communications in Mass Spectrometry*, 25(7), 851-860.
- Wendeberg M., J.M. Richter, M. Rothe and W.A. Brand, 2013: Jena Reference Air Set (JRAS): a multi-point scale anchor for isotope measurements of  $\text{CO}_2$  in air, *Atmospheric Measurement Techniques*, 6(3), 817-822.

WMO, All WMO references below are available from

<http://www.wmo.int/pages/prog/arep/gaw/gaw-reports.html>

WMO, 2001: Strategy for the Implementation of the Global Atmosphere Watch Programme (2001-2007), A Contribution to the Implementation of the Long-Term Plan, GAW Report No. 142, WMO TD No.1077.

WMO, 2003: Updated Guidelines for Atmospheric Trace Gas Data Management, GAW Report No. 150, WMO TD No. 1149.

WMO, 2005: Global Atmosphere Watch, 12th WMO/IAEA Meeting of Expert on Carbon Dioxide Concentration and Related Tracers Measurements Techniques (Toronto, Canada, 15-18 September 2003) GAW Report No.161, WMO TD No. 1275.

WMO, 2007: Global Atmosphere Watch (GAW) Strategic Plan: 2008-2015, GAW Report No. 172, WMO TD NO.1384.

WMO, 2009: Guidelines for the Measurement of Methane and Nitrous Oxide and their Quality Assurance, GAW Report No. 185. WMO TD No. 1478.

WMO, 2009: Revision of the World Data Centre for Greenhouse Gases Data Submission and Dissemination Guide, GAW Report No. 188, WMO TD No.1507.

WMO, 2010: Guidelines for the Measurement of Atmospheric Carbon Monoxide, GAW Report No. 192. WMO TD No. 1551.

WMO, 2011: Addendum for the Period 2012 – 2015 to the WMO Global Atmosphere Watch (GAW) Strategic Plan 2008–2015, GAW Report No. 197.

Zellweger, C., L. Emmenegger, M. Firdaus, J. Hatakka, M. Heimann, E. Kozlova, T.G. Spain, M. Steinbacher, M.V. van der Schoot and B. Buchmann, 2016: Assessment of recent advances in measurement techniques for atmospheric carbon dioxide and methane observations, *Atmospheric Measurement Techniques Discuss.*, 2016, 1-30.

---

## ANNEX I

**18<sup>th</sup> WMO/IAEA Meeting on Carbon Dioxide, Other Greenhouse Gases  
and Related Tracers Measurement Techniques (GGMT-2015)**

**(La Jolla, USA , 13-17 September 2015)**

**LIST OF PARTICIPANTS**

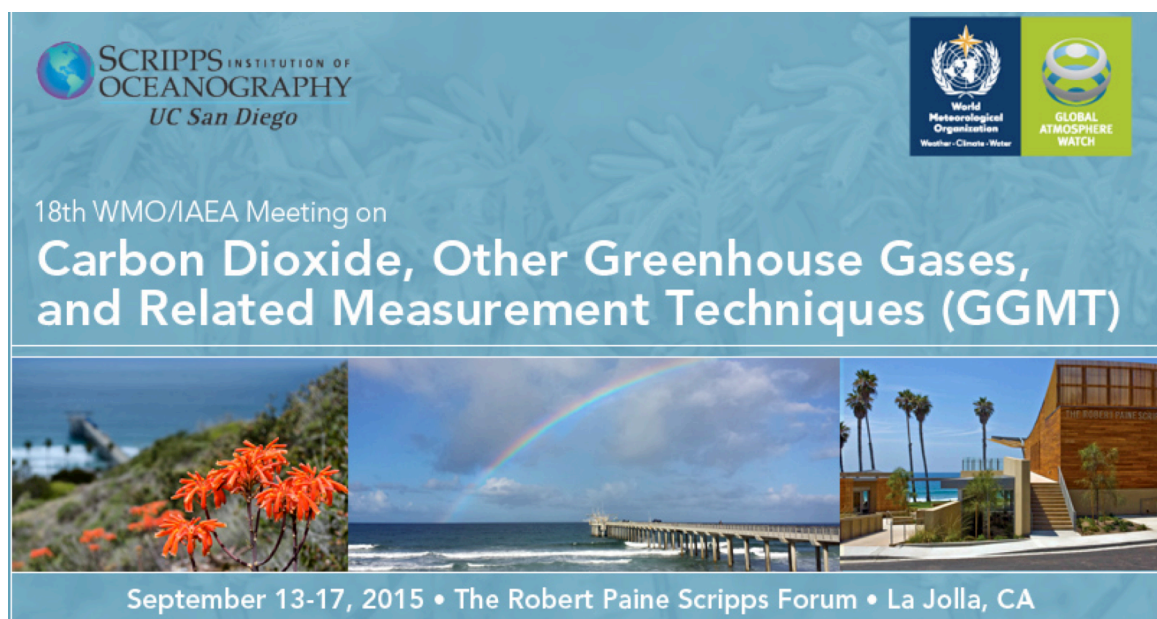
<i>First Name</i>	<i>Last Name</i>	<i>Email address</i>
Hermann	AALTONEN	hermann.aaltonen@fmi.fi
Arlin	ANDREWS	arlin.andrews@noaa.gov
Shuji	AOKI	aoki@m.tohoku.ac.jp
Tim	ARNOLD	timothy.arnold@metoffice.gov.uk
Shiv Dev	ATTRI	sdattri@gmail.com
Douglas	BAER	d.baer@lgrinc.com
Thomas	BARNINGHAM	stbarningham@gmail.com
Jonathan	BENT	jbent@ucar.edu
Sebastien	BIRAUD	scbiraud@lbl.gov
Romain	BLOT	blot.romain@gmail.com
Alane	BOLLENBACHER	abollenbacher@ucsd.edu
Gordon	BRAILSFORD	Gordon.Brailsford@niwa.co.nz
Willi A.	BRAND	wbrand@bgc-jena.mpg.de
Paul	BREWER	paul.brewer@npl.co.uk
Mariela	BROOKS	marielabrooks@gmail.com
James	BUTLER	james.h.butler@noaa.gov
Huilin	CHEN	kvchen25@gmail.com
melanie	CHESTER	melanie.chester@ecotech.com
Adam	COX	accox@ucsd.edu
Kohshiro	DEHARA	dehara@met.kishou.go.jp
Marc	DELMOTTE	marc.delmotte@lsce.ipsl.fr
Edward	DLUGOKENCKY	ed.dlugokencky@noaa.gov
Rocco	DUCHI	frapast1981@yahoo.it
Markus	ERITT	meritt@bgc-jena.mpg.de
Michele	ERNST	michele.ernst@ec.gc.ca
Shuangxi	FANG	fangsx@cma.cma.gov.cn
Grant	FORSTER	g.forster@uea.ac.uk
Christoph	GERBIG	cgerbig@bgc-jena.mpg.de
Angel J.	GOMEZ-PELAEZ	agomezp@aemet.es
Daiuske	GOTO	goto.daisuke@nipr.ac.jp
Heather	GRAVEN	h.graven@imperial.ac.uk
David	GRIFFITH	griffith@uow.edu.au
Peter	GUENTHER	pguenther@ucsd.edu
Manish	GUPTA	manish.gupta@gmail.com
Bradley	HALL	Bradley.Hall@noaa.gov

18<sup>TH</sup> WMO/IAEA MEETING ON CARBON DIOXIDE, OTHER GREENHOUSE GASES AND RELATED TRACERS MEASUREMENT TECHNIQUES (GGMT-2015)

Samuel	HAMMER	shammer@iup.uni-heidelberg.de
Laszlo	HASZPRA	Haszpra.l@met.hu
Lynn	HAZAN	lynn.hazan@lsce.ipsl.fr
Koide	HIROSHI	hkoide@met.kishou.go.jp
Yi-wen	HUANG	y.huang@lgrinc.com
Shigeyuki	ISHIDOYA	s-ishidoya@aist.go.jp
David	JOHNSON	jennifer.trevino@licor.com
Armin	JORDAN	ajordan@bgc-jena.mpg.de
Keiichi	KATSUMATA	katsumata.keiichi@nies.go.jp
Teruo	KAWASAKI	tr_kawasaki@met.kishou.go.jp
Ralph	KEELING	rkeeling@ucsd.edu
Joseph	KIM	kji2080@gmail.com
Duane	KITZIS	duane.r.kitzis@noaa.gov
Serguei	KOULIKOV	serguei.koulikov@licor.com
Paul	KRUMMEL	paul.krummel@csiro.au
Casper	LABUSCHAGNE	casper.labuschagne@weathersa.co.za
Brian	LAFRANCHI	bwlafra@sandia.gov
Olivier	LAURENT	olivier.laurent@lsce.ipsl.fr
Tuomas	LAURILA	tuomas.laurila@fmi.fi
Jost Valentin	LAVRIC	jlavric@bgc-jena.mpg.de
Haeyoung	LEE	leehy80@korea.kr
Scott	LEHMAN	Scott.Lehman@colorado.edu
Markus	LEUENBERGER	leuenberger@climate.unibe.ch
Ingeborg	LEVIN	Ingeborg.Levin@iup.uni-heidelberg.de
Bing	LIN	bing.lin@nasa.gov
Lixin	LIU	lixin.liu@noaa.gov
Tim	LUEKER	tlueker@ucsd.edu
Toshinobu	MACHIDA	tmachida@nies.go.jp
Andrew	MANNING	andrew.uea@gmail.com
Douglas	MARTINS	dkm18@psu.edu
Ken	MASARIE	kenneth.masarie@noaa.gov
Kathryn	MCKAIN	kathryn.mckain@noaa.gov
Thomas	MEFFORD	Thomas.Mefford@noaa.gov
Frank	MEINHARDT	frank.meinhardt@uba.de
Sylvia	MICHEL	sylvia.englund@colorado.edu
Sara	MIKALOFF-FLETCHER	Sara.Mikaloff-Fletcher@niwa.co.nz
Natasha	MILES	nmiles@met.psu.edu
Benjamin R	MILLER	ben.r.miller@noaa.gov
John	MILLER	john.b.miller@noaa.gov
Blagoj	MITREVSKI	mit20f@csiro.au
Eric	MORGAN	ericjmorgan@gmail.com
Jens	MUHLE	jmuhle@ucsd.edu
Philippe	NEDELEC	nedp@aero.obs-mip.fr
Euan	NISBET	e.nisbet@rhul.ac.uk
Anders	NOTTROTT	anottrott@picarro.com
Paul	NOVELLI	paul.c.novelli@noaa.gov
Hisahi	ONO	ono-hi@met.kishou.go.jp
Yumi	OSONOI	osonoi.yumi@nies.go.jp



William	PAPLAWSKY	wpapl@ucsd.edu
Prabir	PATRA	prabir@jamstec.go.jp
Penelope	PICKERS	p.pickers@uea.ac.uk
Steve	PIPER	scpipper@ucsd.edu
Maria Elena	POPA	epopa2@yahoo.com
Michel	RAMONET	michel.ramonet@lsce.ipsl.fr
Christopher	RELLA	rella@picarro.com
Scott	RICHARDSON	srichardson@psu.edu
Ludwig	RIES	ludwig.ries@uba.de
Christian	RÖDENBECK	Christian.Roedenbeck@bgc-jena.mpg.de
Daniel	RZESANKE	daniel.rzesanke@bgc-jena.mpg.de
Karri	SAARNIO	karri.saarnio@fmi.fi
Peter	SALAMEH	psalameh@ucsd.edu
Daisuke	SASANO	dsasano@mri-jma.go.jp
Yosuke	SAWA	ysawa@mri-jma.go.jp
H.A.	SCHEEREN	h.a.scheeren@rug.nl
Martina	SCHMIDT	Martina.Schmidt@iup.uni-heidelberg.de
Hratch	SEMERJIAN	hratch.semerjian@gmail.com
Andrew	SMITH	ams@ansto.gov.au
Peter	SPERLICH	peter.sperlich@niwa.co.nz
Ann	STAVERT	ann.stavert@bristol.ac.uk
Martin	STEINBACHER	martin.steinbacher@empa.ch
Britton	STEPHENS	stephens@ucar.edu
Pieter	TANS	Pieter.Tans@noaa.gov
Hiroshi	TATSUMI	handglobe@gmail.com
Yukio	TERAO	yterao@nies.go.jp
Yasunori	TOHJIMA	tohjima@nies.go.jp
Jocelyn	TURNBULL	j.turnbull@gns.cri.nz
Sander	VAN DER LAAN	svanderlaan1978@gmail.com
Marcel	VAN DER SCHOOT	marcel.vanderschoot@csiro.au
Sanam	VARDAG	svardag@iup.uni-heidelberg.de
Bruce	VAUGHN	bruce.vaughn@colorado.edu
Kristal	VERHULST	Kristal.R.Verhulst@jpl.nasa.gov
Alex	VERMEULEN	Alex.Vermeulen@nateko.lu.se
Joële	VIALLON	jviallon@bipm.org
Felix	VOGEL	Felix.Vogel@lsce.ipsl.fr
Stephen	WALKER	sjwalker@ucsd.edu
Ray	WEISS	rfweiss@ucsd.edu
Paul	WENNBERG	wennberg@caltech.edu
James	WHETSTONE	james.whetstone@nist.gov
Jim	WHITE	susan.ponsor@colorado.edu
Irène	XUEREF-REMY	irene.xueref@lsce.ipsl.fr
Mayu	YAMAMOTO	tmrr.y.1017@gmail.com
Christoph	ZELLWEGER	christoph.zellweger@empa.ch
Lingxi	ZHOU	zhoulx@cams.cma.gov.cn



## MEETING AGENDA

### Sunday, 13 September 2015

All day: Kayak La Jolla Shores and beach activities  
 18:00 ICE BREAKER

### Monday, 14 September 2015

8:00 REGISTRATION  
 9:00 Opening Remarks  
 9:40 Keynote: Airborne measurements of oxygen concentration from the surface to the lower stratosphere (*Britt Stephens*)  
 10:10 PHOTO AND COFFEE BREAK

#### Urban Networks and Megacities – Chair: Britt Stephens

10:40 Assessing CO<sub>2</sub> emissions from Paris megacity: first lessons from our atmospheric CO<sub>2</sub> network, co-emitted species and carbon isotopes; observation strategy for future urban CO<sub>2</sub> networks (*Xueref-Remy*)  
 11:00 Indianapolis flux (INFLUX) in situ network: quantification of urban atmospheric boundary layer greenhouse gas dry mole fraction enhancements (*Miles*)  
 11:10 Early results from the Los Angeles megacity carbon project: exploring spatial and temporal variability in urban greenhouse gas observations (*Verhulst*)

11:20 Observations of atmospheric CO<sub>2</sub>, CO and CO<sub>2</sub> isotopes across an experimental tower network in California (*Graven*)

**GHG Standards & Comparison Activities – Chair: Britt Stephens**

11:30 History of WMO CO<sub>2</sub> X2007 scale: long-term reproducibility (*Tans*)

11:50 Results from the latest Round-Robin comparison (*Lingxi Zhou*)

12:00 LUNCH BREAK

**GHG Standards & Comparison Activities, continued – Chair: Gordon Brailsford**

13:20 Comparison of CO<sub>2</sub> in air standards for background and urban GHG measurements, (*Viallon*)

13:40 Update and expansion of the WMO X2004 methane mole fraction scale (*Dlugokencky*)

14:00 WMO/GAW greenhouse gas calibration scales: definitions, uncertainties, and future directions (*Hall*)

14:20 Reference standards for carbon dioxide and other high impact greenhouse gases (*Brewer*)

14:40 Recommendations 1,2: Calibration of GAW & CO<sub>2</sub> Calibration

15:10 BREAK

15:30 Poster Session 1

16:30 Recommendations 6,7,8: Calibration of CH<sub>4</sub>, N<sub>2</sub>O, SF<sub>6</sub>

17:00 ADJOURN

**Tuesday, 15 September 2015**

**GHG Standards & Comparison Activities, continued – Chair: Brad Hall**

8:30 Update on the WMO H<sub>2</sub> X2009 scale (*Jordan*)

8:50 Tracking drift in WMO primary CO standards (*Crotwell*)

9:10 A new scale for measurements of atmospheric carbon monoxide (*Novelli*)

**Isotope Measurements – Chair: Brad Hall**

9:30 Keynote: Stable isotopes of atmospheric gases measured by the NOAA-CU INSTAAR Cooperative Program (*James White*)

10:00 COFFEE BREAK

**Isotope Measurements, continued – Chair: Heather Graven**

10:20 Jena ISO-CCL and the JRAS–06 scale for atmospheric CO<sub>2</sub> (*Brand*)

10:35 IAEA stable isotope reference materials: Addressing the needs of atmospheric measurements (*Assonov*)

- 10:50 Compatibility of low level counting (LLC) and accelerator mass spectrometry (AMS) techniques for atmospheric radiocarbon measurements: a status report of the buildup of the ICOS Central Radiocarbon Laboratory (CRL) (*Hammer*)
- 11:10 A proposal for a suite of isotope reference gases for CH<sub>4</sub> in synthetic air (*Sperlich*)
- 11:30 Recommendations 3,4: Stable isotopes and radiocarbon
- 12:00 LUNCH BREAK (including vendor presentations)

### **GHG Standards & Comparison Activities, continued – Chair: Armin Jordan**

- 13:20 Traceability of measurements within the Global Atmosphere Watch programme: results from the World Calibration Centre WCC-Empa (*Zellweger*)
- 13:40 An update of comparisons of non-CO<sub>2</sub> trace gas measurements between AGAGE and NOAA at common sites (*Krummel*)
- 13:50 Compatibility of atmospheric greenhouse gas measurements in Europe as assessed by the 'Cucumbers' Intercomparison Programme (Manning)

### **Measurement Techniques & Calibration – Chair: Tim Lueker**

- 14:00 Regular airborne GHG observations within IAGOS: QA/QC approach (*Gerbig*)
- 14:20 PERSEUS: a sample pre-concentration and GC/MS detector system for analysis of flask air samples for atmospheric trace halocarbons, hydrocarbons and sulfur-containing compounds (*Miller*)
- 14:40 EXCURSION TO TORREY PINES PARK OR DOWNTOWN LA JOLLA
- 17:30 BREAK
- 18:30 BANQUET AT BIRCH AQUARIUM
- 22:30 ADJOURN

## **Wednesday, 16 September 2015**

### **Ocean Measurements – Chair: Ralph Keeling**

- 8:30 An overview of the Scripps program to produce and distribute reference materials for oceanic CO<sub>2</sub> measurements (*Dickson*)
- 8:50 Recommendations for ocean and atmospheric measurements of CO<sub>2</sub> on ships of opportunity (*Sweeney*)

### **Site and Network Updates – Chair: Ralph Keeling**

- 9:10 UK DECC & GAUGE tall tower networks and integration with other greenhouse gas data streams (*Stavert*)
- 9:30 Speed talks
- 9:50 COFFEE BREAK

**Site and Network Updates – Chair: Martina Schmidt**

- 10:20 Speed talks
- 10:40 Poster Session II
- 11:40 Recommendations 13, Cooperative WMO/GAW network
- 12:10 LUNCH BREAK (including vendor presentations)

**Measurement Techniques & Calibration, continued – Andrew Manning**

- 13:30 Trends of methane emissions in southern Germany derived from 24 years of atmospheric methane and radon measurements at Schauinsland station (*Schmidt*)
- 13:50 High-precision in situ atmospheric measurements of COS, CO<sub>2</sub>, CO AND H<sub>2</sub>O at the Lutjewad tower in the Netherlands (*Chen*)
- 14:10 A system for continuous measurements of atmospheric O<sub>2</sub>/N<sub>2</sub> and Ar/N<sub>2</sub> ratio, stable isotopic ratios of N<sub>2</sub>, O<sub>2</sub> and Ar and its application in preparing gravimetric standards for atmospheric O<sub>2</sub>/N<sub>2</sub> ratio (*Ishidoya*)
- 14:30 Interferometric and mass spectrometric measurements of O<sub>2</sub>/N<sub>2</sub> ratio at the Scripps Institution of Oceanography (*Keeling*)
- 14:50 BREAK
- 15:10 Side sessions and lab tours
- 16:40 Recommendations 9,10: CO and H<sub>2</sub> calibration
- 17:10 Additional lab tours
- 18:10 ADJOURN

**Thursday, 17 September 2015****Emergent Techniques – Chair: Pieter Tans**

- 8:30 Regional and global atmospheric CO<sub>2</sub> measurements using 1.57 micron IM-CW Lidar (*Lin*)
- 8:50 In situ methane in the third dimension – using drones to 3000m in ascension island, to sample tropical air (*Thomas*)
- 9:10 Long open path Fourier Transform spectroscopy measurements of greenhouse gases in the atmosphere (*Griffith*)
- 9:30 Keynote: An update on recent results from OCO-2 and the TCCON network (*Paul Wennberg*)
- 10:00 COFFEE BREAK

**Emergent Techniques, continued – Chair: James Butler**

- 10:30 Trace gas measurements by GC-PDD (Mitrevski)

**Integration of Observations, Data Products and Policy – Chair: James Butler**

- 10:50 Complementary ObsPack data products: a new way to think about cooperative data products (*Masarie*)
- 11:10 Proposed new interface for metadata input at the WDCGG website (*Yamamoto*)
- 11:30 Informing policy with observations and modeling – an opportunity (*Butler*)
- 11:50 LUNCH BREAK (including vendors presentations)
- 13:10 Recommendations 12. Data management and archiving

**Isotope Measurements, continued – Chair: Willi Brand**

- 13:40 A 21st century shift from fossil-fuel to biogenic methane emissions indicated by  $^{13}\text{CH}_4$ , (*Mikalov-Fletcher*)
- 14:00 60 years of southern hemisphere?  $^{14}\text{CO}_2$  observed at Wellington, New Zealand (*Turnbull*)
- 14:20 Measurements of the stable isotopes  $^{13}\text{C}$  and  $^{18}\text{O}$  in atmospheric CO at IMAU, Utrecht university (NL) (*Popa*)
- 14:40 BREAK
- 15:10 Expert group recommendations
- 17:00 FINAL ADJOURNMENT
-

**ANNEX III****18<sup>th</sup> WMO/IAEA Meeting on  
Carbon Dioxide, Other Greenhouse Gases and Related Tracers Measurement  
Techniques (GGMT-2015)****(La Jolla, USA, 13-17 September 2015)****POSTER SESSION A**

A1

Gas Adsorption and Desorption Effects on Cylinders and their Importance for Long-Term Gas Records (M. Leuenbeger)

A2

Long-Term CO<sub>2</sub> and Ozone Measurements on a Global Scale from IAGOS In-Service Aircraft (R. Blot)

A3

Estimation in CO Flux in Forest of Regional Scale by Observation of Atmospheric CO Concentration by Top-Down Methods (S. Nomura)

A4

Inferring 222radon Soil Flux from Ambient 222radon Activity and Eddy Covariance Measurements (S. Van Der Laan)

A5

ICOS ATC Metrology Lab: Metrological Performance Assessment of GHG Analyzers (O. Laurent)

A6

Network of Carbon Dioxide Measurements in the Southeast United States - Results from the Gulf Coast Intensive (S. Richardson)

A7

Evaluation and Quality Assessment of 8 Years (2006 - 2013) of N<sub>2</sub>O and SF<sub>6</sub> Observations at Lutjewad Monitoring Station, The Netherlands (B. Scheeren)

A8

Isotope Ratio Infrared Spectrometer to Continuously Monitor Carbon and Oxygen Isotopologues of CO<sub>2</sub> (H. Jost)

A9

Characterization of Continuous OCS, CO, and CO<sub>2</sub> Measurements at a Tower Site in Livermore, CA, USA (B. La Franchi)

A10

Amazon Basin: an Important Source of Methane? (L. Basso)

A11

Study of SF<sub>6</sub> Concentrations in Amazon Basin and Brazilian Coast (L. Gatti)

A12

Four Years Carbon Monoxide Vertical Profiles Study at the Amazon Basin  
(L. Domingues)

A13

CO Measurement Issues Encountered by MPI -BGC GASLAB  
(A. Jordan)

A14

A Study of External Factors Promoting Variability in MECD Response  
(L. Gatti)

A15

A Sensitivity Study on the Estimation of Continuous Anthropogenic CO<sub>2</sub> Using CO<sub>2</sub>, CO,  $\delta$ <sup>13</sup>C - CO<sub>2</sub>, O<sub>2</sub>/N<sub>2</sub> and  $\Delta$  <sup>14</sup>C - CO<sub>2</sub>  
(S. Varda)

A16

Aircore Observations of CO<sub>2</sub>/CH<sub>4</sub>/CO over the Sodankylä TCCON Site  
(H. Chen)

A17

Comparison of Carbon Dioxide Mixing Ratios from In-Situ Measurements by NDIR and CRDS Analyzers and Bottle Sampling Measurements at Hateruma Island  
(K. Katsumata)

A18 NOAA/GMD Standards Preparation and CO<sub>2</sub> Calibration Transfer

(D. Kitzis)

A19

Results of Flask Air Sampling Intercomparison Programs at the Alert, Nunavut GHG Comparison Site  
(M. Ernst)

A20

A European - Wide Intercomparison of Atmospheric <sup>222</sup>Rn and <sup>222</sup>Rn Rogeny Measurements  
(I. Levin)

A21

Comparisons of CO<sub>2</sub> and Other Greenhouse Gases Sampled by Three Different Methods in the CONTRAIL Project  
(Y. Sawa)

A22

Inter-Comparison Experiments of Standard Gases for JMA/WCC Activity  
(T. Kawasaki)

A23

Recent Activities of WMO/GAW World Calibration Centre - SF<sub>6</sub>  
(H. Lee)

A24

Assessing the Impact of C<sub>2</sub>H<sub>6</sub> on Atmospheric  $\delta$ <sup>13</sup>CH<sub>4</sub> Measurements at Industrial Sites when Using a Cavity Ring Down Spectrometer  
(S. Assan)



A25

Fossil Fuel and Biogenic Partitioning in CO<sub>2</sub> Emissions from East Asia Determined by High-Frequency Radiocarbon Measurements at Hateruma Island  
(Y. Terao)

A26

Testing the Delta Ray Instrument to Measure Isotope Ratios of Carbon Dioxide in Air Under Laboratory Conditions and at Baring Head, New Zealand  
(P. Sperlich)

A27

Characterization of the Response of Cavity Ring-Down Spectrometer Methane Stable Isotopic Ratios to Changes in Methane Concentration  
(D. Martins)

A28

Installation and Current Status of CAMS System at NIES  
(Y. Osonoi)

A29

Stable Isotope Measurements on Air Samples for the ICOS Network  
(M. Erritt)

A30

Radio - Methane Processing and Measurement at CU - INSTAAR  
(S. Lehman)

A31

Rising Global Methane - Using  $\delta^{14}\text{C}$  in CH<sub>4</sub> to Decipher the Causes  
(E. Nisbet)

A32

Online Measurements of Greenhouse Gases and Carbon Isotopes in a CO<sub>2</sub> Extraction System using a Cavity Ring - Down Spectrometer  
(F. Vogel)

## POSTER SESSION B

B1

An Assessment of Air Pollution Levels in Athi River Township and Olkaria Ecosystems, Kenya  
(Z. Shilenje)

B2

GGMT - 2015 Izaña Station Update: Instrumental and Processing Software Developments, Scale Updates, Aircraft Campaign, and Plumbing Design For CRDS  
(A. Gomez - Pelaez)

B3 Greenhouse Gases Monitoring At Chacaltaya Gaw Station, Bolivia, \*M. Ramonet

B4

The Determination of Regional CO<sub>2</sub> Mole Fractions at Three WMO/GAW Regional Stations in China  
(S. Fang)

B5

Greenhouse Gas Observation Network of Japan Meteorological Agency in the  
Western North Pacific  
(K. Dehara)

B6

Mobile Laboratory as a Part of Internal Quality Control of ICOS Atmospheric Station Network  
(K. Saarnio)

B7

Quantifying the Net Exchange Ecosystem for Different Land Use in Pampa Biome  
in Southern Brazil  
(D. Roberti)

B8

New CRDS Observations (CO, CH<sub>4</sub>, CO<sub>2</sub>) at Three Permanent Observatories in the South of  
Italy in the Framework of the I - AMICA Project  
(R. Duchi)

B9

National Greenhouse Gases Monitoring Networks in India  
(Sd. Attri)

B10

Implementation of Long - Term Greenhouse Gas Observation Capacities in Chile and Vietnam,  
(M. Steinbacher)

B11

Three Years of Continuous Vertically Resolved CO<sub>2</sub>/CH<sub>4</sub>/CO Measurements at the Amazon Tall  
Tower Observatory Site (Atto, Brazil)  
(J. Lavric)

B12

Observation Network for Greenhouse Gases and Related Species in the New  
Zealand Region  
(G. Brailsford)

B13

ICOS Atmosphere Thematic Center  
(L. Hazan)

B14

Initial Operation of the Flask and Calibration Laboratory for ICOS (Integrated Carbon  
Observation System)  
(D. Rzesanke)

B15

Monitoring of Atmospheric Carbon Dioxide and Other GHG's in India: Implications for  
Constraining Indian Emissions  
(Y. Tiwari)

B16

Continuous Measurements of CO<sub>2</sub> and CH<sub>4</sub> during 2011 - 2014 at Pondicherry, India  
(I. Nuggehalli)

B17

Long - Term Measurements of Atmospheric Trace Gases ( $\text{CO}_2$ ,  $\text{CH}_4$ ,  $\text{N}_2\text{O}$ ,  $\text{SF}_6$ ,  $\text{CO}$ ,  $\text{H}_2$ ),  $\text{O}_2$ , and  $\delta^{13}\text{C}$  Isotopes at Weybourne Atmospheric Observatory, UK: Past, Present and Future  
(G. Forster)

B18

Amazon and Coast Brazilian Greenhouse Gas Measurement Program and the Efforts in Construct the GHG Network  
(L. Gatti)

B19

The Carbon Related Atmospheric Measurement (CRAM) Laboratory: A United Kingdom National Report  
(A. Manning)

B20

Eight Years of In Situ Measurements of  $\text{CH}_4$ ,  $\text{N}_2\text{O}$  and  $\text{CO}$  Made with a Prototype Fourier Transform Trace Gas Analyser at Lauder, New Zealand  
(G. Brailsford)

B21

Ground and Airborne Based Observations of Greenhouse Gases Mixing Ratios at US - DOE Atmospheric Radiation Measurement Facilities  
S. Biraud

B22

The French Metropolitan Greenhouse Gases Monitoring Network: SNO - ICOS France  
(M. Delmotte)

B23

Developments In The CSIRO Australian Greenhouse Gas Observation Network  
(M. Van Der Schoot)

B24

5 Years of Brazilian Greenhouse Gases Background Concentrations  
(Vf Borges)

B25

Improvements of the Spectronus FTIR Instrument for Application in Static Mode at Tall Towers  
(A. Vermeulen)

B26

Improvements to Picarro's G2401 and G2301 - ICOS Compliant Reproducibility, and Improved Drift Specifications in Response to Results from ICOS Instrument Comparison  
(G. Leggett)

B27

Japan Meteorological Agency's Ship - Based Observation for the Partial Pressure of Carbon Dioxide in the Western North Pacific  
(H. Ono)

B28

The In - Situ Measurement of Greenhouse Gases ( $\text{CO}_2$ ,  $\text{CH}_4$ ,  $\text{N}_2\text{O}$  &  $\text{CO}$ ) Dissolved in Inland Waters and their Water - Atmosphere Exchange  
(D. Griffith)

B29

Continuous Measurements of XCO<sub>2</sub> and XCH<sub>4</sub> in the Seawater and Overlying Air in the Western Arctic Ocean  
(D. Sasano)

B30

Improvements in Short - Term Atmospheric Oxygen Measurement Precision by Faster Sample - Reference Switching  
(P. Pickers)

B31

Preliminary Results on O<sub>2</sub>/N<sub>2</sub> Scale Comparison Between SIO and NIES Based on Flask Sampling at La Jolla  
(Y. Tohjima)

B32

Observations of an Interhemispheric Gradient, and Stratospheric Depletion in the Atmospheric AR/N<sub>2</sub> Ratio during the HIPPO Global Campaign  
(J. Bent)

B33

Progress in Data Management and Information Provision of WDCGG  
(H. Koide)

B34

Estimating CO<sub>2</sub> Sinks and Sources in New Zealand from Atmospheric Measurements and Lagrangian Modelling  
(S. Mikaloff Fletcher)

B35

Revisit the Global Average of GHGs Abundances by the WDCGGg Method  
(H. Tatsumi)

B36

The Tricks of the Climate Politicians  
(J. Butler)

B37

Processing of CO<sub>2</sub>, CH<sub>4</sub> and CO Mole Fractions at the ICOS Atmospheric Thematic Center  
(L. Haza)

---

## WORKSHOP PROCEEDINGS

### A STUDY OF EXTERNAL FACTORS PROMOTING VARIABILITY IN $\mu$ ECD RESPONSE

Caio S. C. Correia<sup>1,2</sup>, Lucas G. Domingues<sup>1,2</sup>, Luciana V. Gatti<sup>1,2</sup>, Ricardo S. Santos<sup>2</sup>, Wellison R. Costa<sup>2</sup>, Gilberto Fisch<sup>3</sup>, Emanuel Gloor<sup>4</sup>, John B. Miller<sup>5</sup>

1. IPEN/CQMA/LQA (Nuclear and Energy Research Institute), Sao Paulo, SP, Brazil
2. INPE/CCST/LaGEE (National Institute of Space Research)
3. CTA (Centro Técnico Aeroespacial)
4. University of Leeds, School of Geography, UK
5. NOAA/ESRL/GMD (Global Monitoring Division), Boulder, Colorado, US

#### 1. Introduction

The Nitrous Oxide ( $N_2O$ ) is the third most important natural greenhouse gas (GHG) on Earth, it has a global warming potential of  $\sim 310$  times higher than carbon dioxide ( $CO_2$ ) and its lifetime is about 120 years (WMO, 2015). Its main sources are nitrification and denitrification promoted by microorganisms, which are mainly affected by agricultural activities.

$N_2O$  concentrations on the Amazon atmosphere are between 320 and 330 ppb, which demands very good precision and accuracy in order to minimize errors at the analysis and therefore flux calculations.

Previous studies performed by this group demonstrated that external factors could influence in nitrous  $N_2O$  analysis performed by gas chromatography (GC) with Electron Capture Detector (ECD). Together with these past studies, to minimize the interference effects on analyses, since 2012, the analysis were performed in triplicate, enabling a better understanding of the detector variability as it is more than 3500 samples per year in average and to obtain more reliable concentrations results. Suspecting that the covariance of  $N_2O$  and  $CO_2$  concentrations could be a technical ECD problem, a new detector was acquired to substitute the old one, and the experiments were repeated to verify the interference of external factors in the  $N_2O$  analysis.

#### 2. Methodology

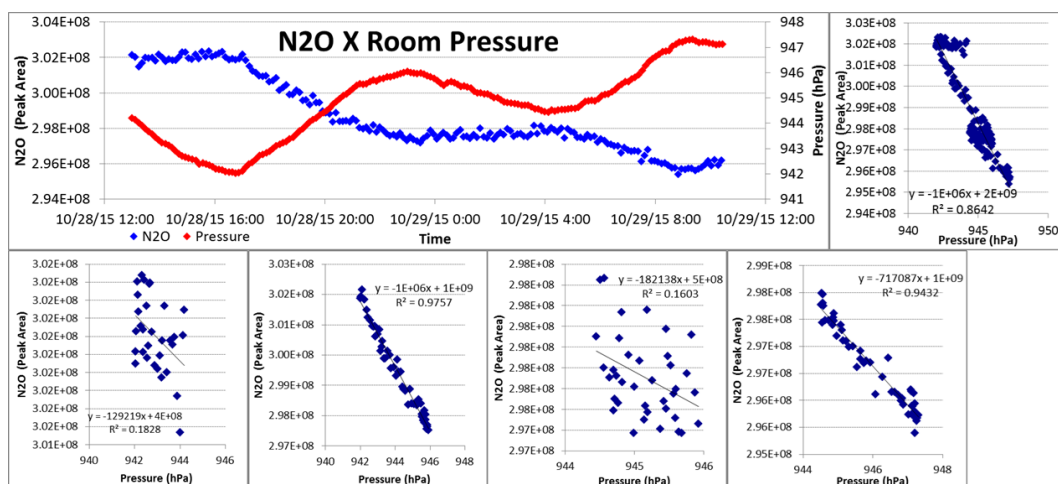
The new detector is a micro Electron Capture Detector ( $\mu$ ECD), which use Argon–Methane (5%) as carrier gas. This gas provides a higher ECD sensitivity than  $N_2$  or Ar gases (Wang et al., 2010). The pre-column and column used were both stainless steel 3/16" ED, 183cm length, packed with HayeSep® Q 100/120 mesh. Loop with 15ml volume and oven with constant temperature of 70°C. The  $\mu$ ECD temperature was 350°C.

The tests involved variation in temperature, pressure and carbon dioxide ( $CO_2$ ) concentrations in room ambient conditions. The room temperature is controlled by a regular air conditioning system which varies  $\pm 1^\circ C$  of the set temperature. The instrument used to measure  $CO_2$  concentrations and room temperature was a TSI Q-Trak Plus IAQ Monitor 8552® and the instrument used to acquire room pressure was a Druck DPI 740 Precision Pressure Indicator®, both connected in a computer to obtain the data for analysis.

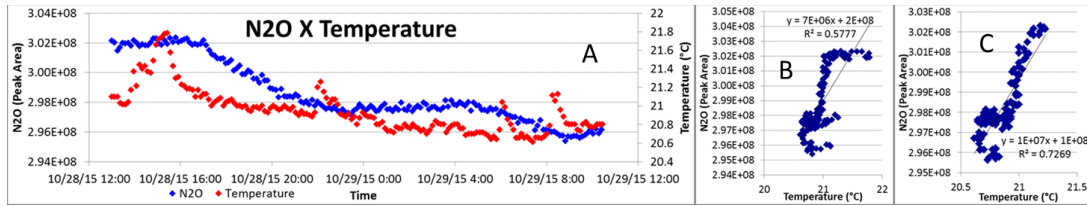
It was performed three separated tests, the first one (Test 1) lasted 24 hours without any external interference, the door remained closed since it started until the end of the test. The air conditioning system was kept at constant ventilation speed. The second test (Test 2) was performed in 6 hours, where the laboratory door was opened and closed during the day several times and varying the people number entering the room. One or two people stayed into the laboratory during 10 to 20 minutes while the test was running, because this time is the average time a person stays into the laboratory, the air conditioning system was maintained at the same configuration. Room CO<sub>2</sub> concentrations and room temperature were measured in both tests. In the third test (Test 3), to evaluate the CO<sub>2</sub> influence, it was introduced in the laboratory room 1kg of dry ice to increase the CO<sub>2</sub> ambient concentration, all the conditions were maintained as the previous tests.

### 3. Results and discussion

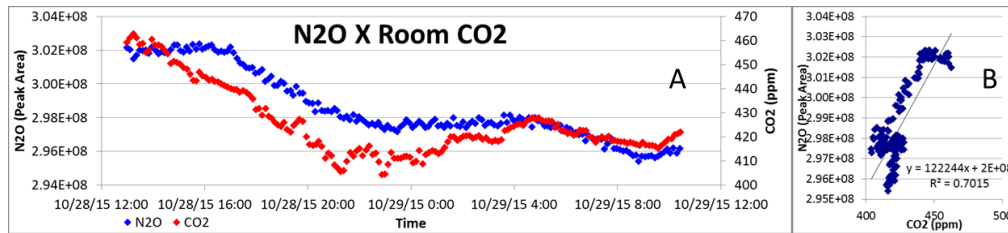
In the Test 1, it is possible to verify in Figure 1, that for the whole time, in general it was observed a anticorrelation between both parameters, where it was found  $R^2$ : 0.86 (Figure 1E). More detailed, when we separated the period in 4 steps, 2 were the pressure is increasing (Figures 1B and D) and 2 decreasing (Figures 1A and C). It was possible to observe that the N<sub>2</sub>O peaks area decreased during both periods where pressure is increasing, with a clear anticorrelation of  $R^2$ : 0.98 in step B and during step D (Figure 1), the  $R^2$  is 0.94. When the pressure was decreasing, it was observed a different behaviour, the N<sub>2</sub>O peaks area were stable, as can be observed in steps A and C, that showed  $R^2$  0.18 and 0.16, respectively. The temperature showed a positive correlation with the N<sub>2</sub>O peaks area for the whole day (Figure 2A), where the  $R^2$  was 0.58 (Figure 2B). The air conditioning showed 4 peaks (< 1°C) in temperature along the test. Studying in details the effect of these peaks, it is possible to observe that there is no influence during the peaks in temperature in the N<sub>2</sub>O peak area. Removing these peaks from time series it was possible to observe a stronger correlation between both parameters ( $R^2 = 0.73$ ) (Figure 2C). During this test, CO<sub>2</sub> concentrations and N<sub>2</sub>O peak area had a very similar behaviour (Figure 3A), and are correlated ( $R^2 = 0.70$ ) (Figure 3B), this study demonstrated that all the observed factors could influence in  $\mu$ ECD signals for N<sub>2</sub>O peak area in the tested conditions.



**Figure 1. Test 1 - N<sub>2</sub>O peak area and room ambient pressure measurements and its correlations of total (E) and the correlation separated by behaviour (A, B, C and D).**

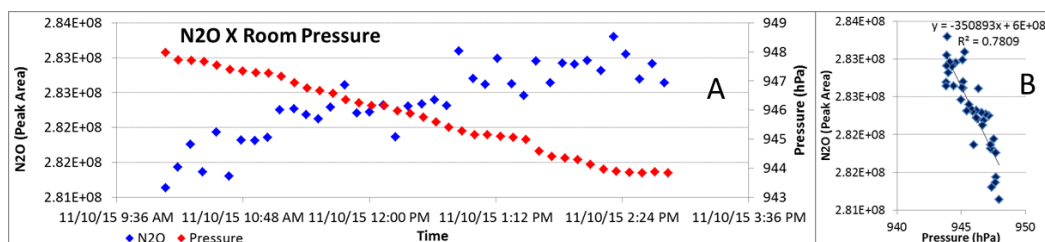


**Figure 2: Test 1 - N<sub>2</sub>O peak area and room ambient temperature (A) and its correlation with (B) and without measures during peaks in temperature (C).**



**Figure 3. Test 1 - N<sub>2</sub>O peak area and room ambient CO<sub>2</sub> (A) and its correlation (B)**

The Test 2, which involved people entering, staying and leaving the room at some periods during the test also showed an inverse correlation, but at this test, as it was performed in a shorter period than the previous one, it was not possible to observe periods of stabilization, probably because of human interference, the signals increased virtually all the time during the test while the room ambient pressure decreased (Figure 4A), an anticorrelation was also found in this test ( $R^2 = 0.78$ ) (Figure 4B). The air conditioning system was not able to keep the room temperature stable in this test and then, it increased in a constant rate about 2°C during the whole test period (Figure 5A), it was possible to observe a direct correlation, either the  $\mu$ ECD response and room temperature increased, N<sub>2</sub>O ( $R^2 = 0.75$ ) (Figure 5B). The measured CO<sub>2</sub> showed no correlation with N<sub>2</sub>O signals. In this case, unfortunately, it is not possible to observe if it was the room pressure, the temperature or both at the same time the factor responsible for the changes.



**Figure 4. Test 2 - N<sub>2</sub>O peak area and room ambient pressure measurements (A) and its correlation (B)**

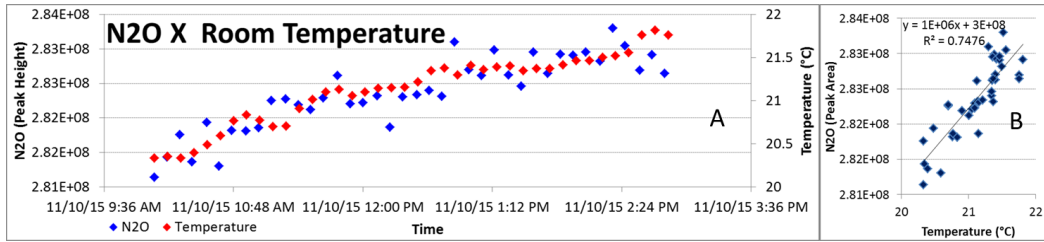


Figure 5. Test 2 - N<sub>2</sub>O peak area and room ambient temperature measurements (A) and its correlation (B)

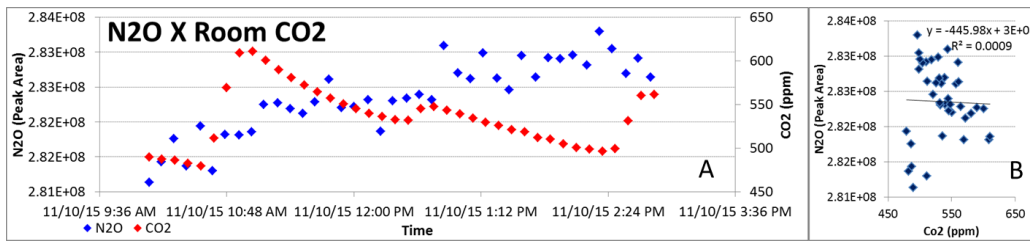


Figure 6. Test 2 - N<sub>2</sub>O peak area and room ambient CO<sub>2</sub> concentration (A) and its correlation (B)

On Test 3, the room pressure showed the same results as before, an anticorrelation ( $R^2 = 0.74$ ) (Figure 7). For temperature it was not found any correlation (Figure 8). The CO<sub>2</sub> source was introduced after two hours running the experiment (Figure 9), and it was found a correlation of  $R^2: 0.41$  in general. When the data was separated by behaviour, it was found a correlation during two periods, the first one when there was only ambient CO<sub>2</sub> and the second when the source was introduced (Figures 6A and B)  $R^2: 0.52$  and  $0.60$  respectively.

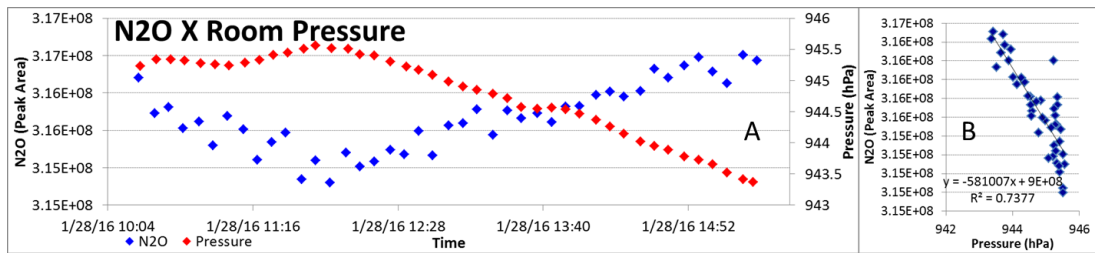


Figure 7. Test 3 - N<sub>2</sub>O peak area and room ambient pressure measurements (A) and its correlation (B)

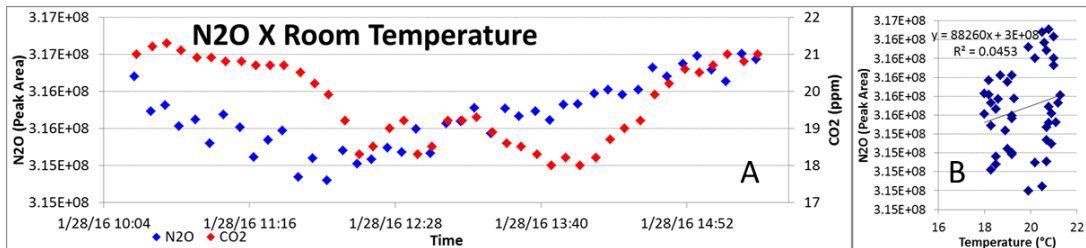
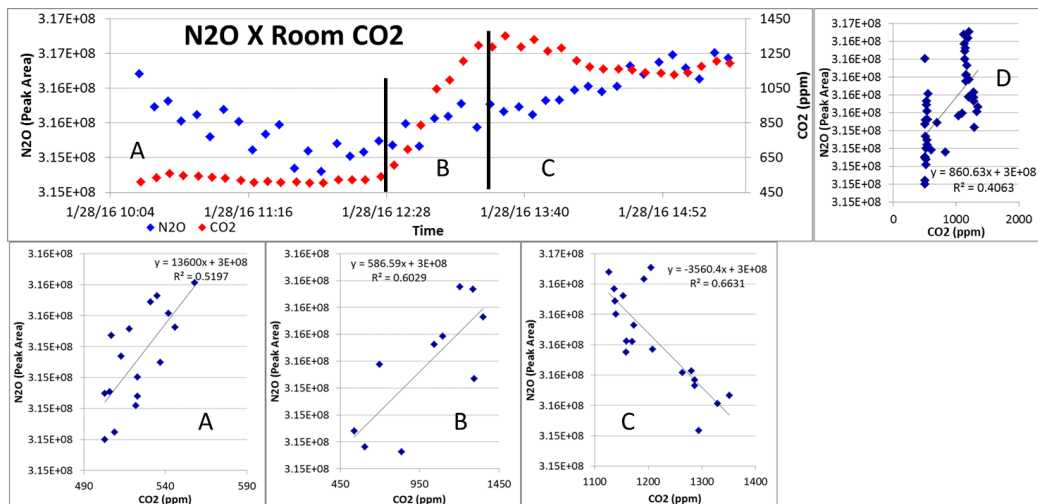


Figure 8. Test 3 - N<sub>2</sub>O peak area and room ambient temperature measurements (A) and its correlation (B)





**Figure 9. Test 3 N<sub>2</sub>O peak area and room ambient CO<sub>2</sub> concentration and its correlations of total (D) and the correlation separated by behaviour (A, B, and C)**

#### 4. Conclusion

This study has shown that the principal external factor that can interfere on the analysis were the ambient Pressure. The interference was anticorrelated, and principally when the pressure increase. Both room CO<sub>2</sub> concentrations and room temperature have shown correlation to the N<sub>2</sub>O peak area, but this correlation is not for the whole studied period, some times it was observed a stable answer in the  $\mu$ ECD response, include during CO<sub>2</sub> and temperature variations.

Understanding why these factors promote influence in the  $\mu$ ECD response is a goal to avoid or correct this variability. More studies are needed to better understand these dependences, however develop a more stable environment condition is the next step to achieve a better precision.

It is important to state that these studied factors even influencing the behaviour of the  $\mu$ ECD response, increasing or decreasing the peaks area or height, are not strong enough to interfere at the precision of the method used for analysis.

#### References

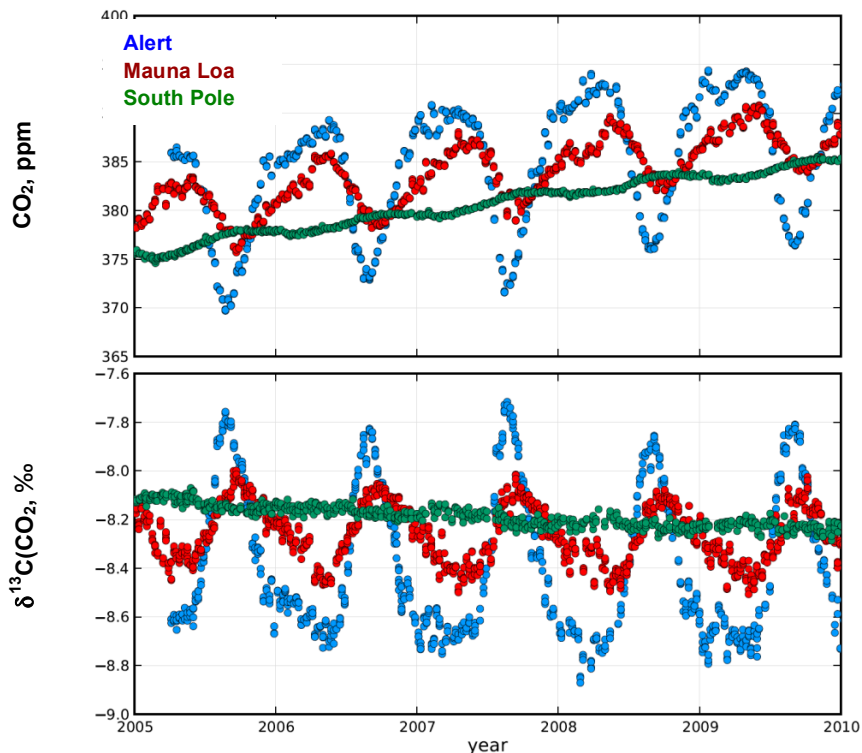
- Wang, Y., and H. Ling, 2010: A new carrier gas for accurate measurements of N<sub>2</sub>O by GC-ECD. *Advances in Atmospheric Sciences*, Vol. 27, NO. 6, 2010, 1322-1330.
- WMO, 2015: Greenhouse Gas Bulletin - *The state of Greenhouse gases in the atmosphere using global observation through 2014*. n. 11, World Meteorological Organization, Geneva, Switzerland.

## IAEA STABLE ISOTOPE REFERENCE MATERIALS: ADDRESSING THE NEEDS OF ATMOSPHERIC GREENHOUSE GAS MONITORING

S. Assonov, M.Gröning and A. Fajgelj, IAEA, Vienna

### 1. Stable isotope measurements in greenhouse gas monitoring (carbon cycle gases)

The concentration of greenhouse gases in the atmosphere has increased greatly over the 20th century, and this increase is ongoing. The sources and sinks of CO<sub>2</sub> and CH<sub>4</sub>, two major greenhouse gases, are very complex; stable isotope data can provide valuable information on the budget of sources and sinks as well as in the study of natural processes in which these gases are involved. Though anthropogenic fluxes (fossil fuels, land use change, agriculture, etc.) are much smaller than the gross natural fluxes (related to oceans and biosphere), anthropogenic fluxes can affect both natural fluxes and global carbon pools (ocean, biosphere, soils, permafrost) to a large degree. As a result, positive feedbacks (release of stored carbon) of the global carbon pools on the climate change and climate extremes are discussed ([1]) and some evidence appears to be observed [2]. In order to appoint sources and sinks of CO<sub>2</sub> and CH<sub>4</sub> and determine feedback mechanisms observational data are used in global modelling. In particular, gradients of values (both spatial and temporal) that are often very small (Fig. 1) give a sensitive record of conditions of the atmosphere, carbon uptake, and release and exchange with carbon pools. In order to make a meaningful interpretation of the observational data, data from different sampling locations, different laboratories, and different years should be synchronised, namely be on the same scale, be compatible within a certain limit and bear a small total uncertainty, also required for stable isotope data.



**Figure 1. Example of spatial and temporal gradients of CO<sub>2</sub> and  $\delta^{13}\text{C}(\text{air-CO}_2)$ ; NOAA/ESRL data downloaded from <http://www.esrl.noaa.gov/>.**

For practical purposes data compatibility is of the highest importance. The WMO/IAEA GGMT meetings [3] recommend the compatibility in  $\delta^{13}\text{C}(\text{air-CO}_2)$  and  $\delta^{13}\text{C}(\text{air-CH}_4)$  for background stations to be at 0.01 and 0.02 ‰ correspondingly. Though these long-term targets do not reflect the total data uncertainty, they imply requirements for the calibrations and their consistency. The calibrations in turn specify the uncertainty requirements for  $\delta^{13}\text{C}$ -Reference Materials (RM), at least for homogeneity and long-term stability.

## 2. $\delta$ -scales: artefact-based relative scales and the highest level RMs

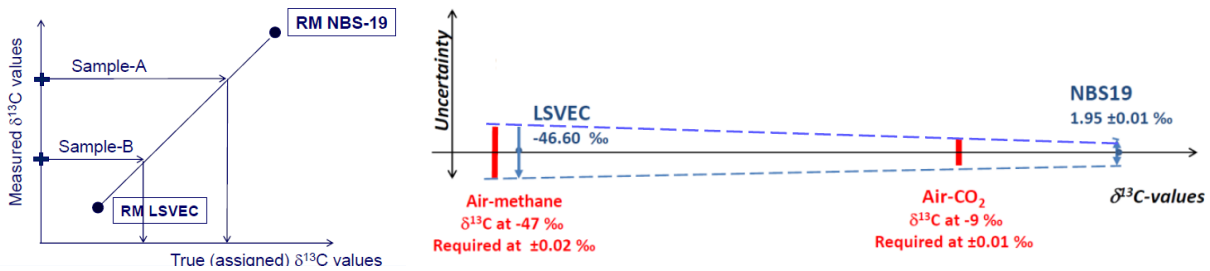
All stable isotope scales, including the VPDB  $^{13}\text{C}$ -scale, are presently artefact-based. This means they are traceable to historical artefact materials which defined scales and their units; the link to SI (System International) traceable numerical ratios is not well established. As precision and accuracy of relative  $\delta$ -measurements are much better than presently available SI-traceable stable isotope determinations, relative measurements are the method of choice for many applications including greenhouse gases.

Until now the RM for the VPDB  $^{13}\text{C}$ -scale realisation has been NBS19 (natural marble, RM exhausted a few years ago). Its value  $\delta^{13}\text{C}=1.95$  ‰ has been accepted exactly, with zero uncertainty (the scale-realisation concept); however the true uncertainty of this RM, while being very small, cannot be not taken as zero (e.g. depends on the sample size in use).

In 2005 LSVEC, Li-carbonate, was introduced as the second high-level  $\delta^{13}\text{C}$ -RM [4, 5], with the aim to introduce a 2-point  $\delta^{13}\text{C}$ -calibration approach (so-called "2-point data normalisation"). LSVEC is the second highest-level  $\delta^{13}\text{C}$ -RM aimed at establishing the scale-calibration span. The LSVEC' value  $\delta^{13}\text{C}=-46.60$  ‰ was introduced with zero uncertainty (concept-value), assuming that its uncertainty is comparable or smaller than the analytical uncertainty of most instruments. IUPAC has officially recommended applying the 2-point  $\delta^{13}\text{C}$ -calibration (based on NBS19/LSVEC, alternatively on 2 other RMs of lower level traceable to NBS19/LSVEC) for all  $\delta^{13}\text{C}$  determinations [5]; this recommendation also applies to  $\delta^{13}\text{C}(\text{air-CO}_2)$  and  $\delta^{13}\text{C}(\text{air-CH}_4)$  determinations.

## 3. The IAEA carbonate RMs: do they fit to requirements of atmospheric monitoring?

NBS19 and LSVEC are the two highest-level RMs for  $\delta^{13}\text{C}$ . As follows from the concept of 2-point  $\delta^{13}\text{C}$ -calibration, the uncertainty of the calibration should be included in  $\delta^{13}\text{C}$  data. In order to minimize the uncertainty of  $\delta^{13}\text{C}(\text{air-CO}_2)$  and  $\delta^{13}\text{C}(\text{air-CH}_4)$  determinations, the measurement traceability chain (number of measurement steps) between RMs in use and samples should be minimized; for this reason it is better to use NBS19/LSVEC as RMs with the lowest uncertainty, or materials directly calibrated vs NBS19/LSVEC. We do not address here the total uncertainty of the values assigned to NBS19 and LSVEC. However, at least some of the uncertainty components need to be included, such as the analytical uncertainty of runs on RMs, and the RM's homogeneity and potential alteration effects due to storage, which directly affect calibrations for  $\delta^{13}\text{C}(\text{air-CO}_2)$  and  $\delta^{13}\text{C}(\text{air-CH}_4)$  and also affect the data compatibility (as illustrated in Figure 2). In other words – the quality of measurement data cannot be better than the quality of the RMs used in the calibrations. In order to reach the compatibility targets, the quality of NBS19 and LSVEC (in fact their homogeneity, stability and the analytical uncertainty) or their replacements should be better than 0.01 and 0.02 ‰.

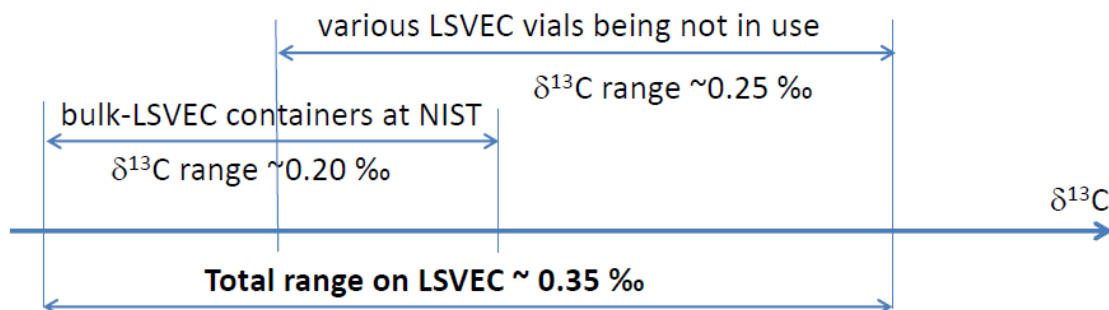


**Figure 2. (a) The 2-point calibration approach; (b) effect of uncertainty components of NBS19 and LSVEC (such as RMs' measurement uncertainty and RMs homogeneity and storage alterations) which directly affect the data compatibility. The data compatibility goals are shown in red.**

Presently the IAEA is preparing RM IAEA-603 as a replacement for NBS19; the material prepared of homogeneous marble with a grain size similar to NBS19. The uncertainty of IAEA-603 is expected to fulfil the requirements of the data compatibility for  $\delta^{13}\text{C}$ (air-CO<sub>2</sub>) at 0.01 ‰; at least the uncertainty-component related to the homogeneity of RM IAEA-603 should be  $\leq 0.01$  ‰. The first batch of 5000 units (0.5g) is sealed in glass ampoules and presently under characterisation.

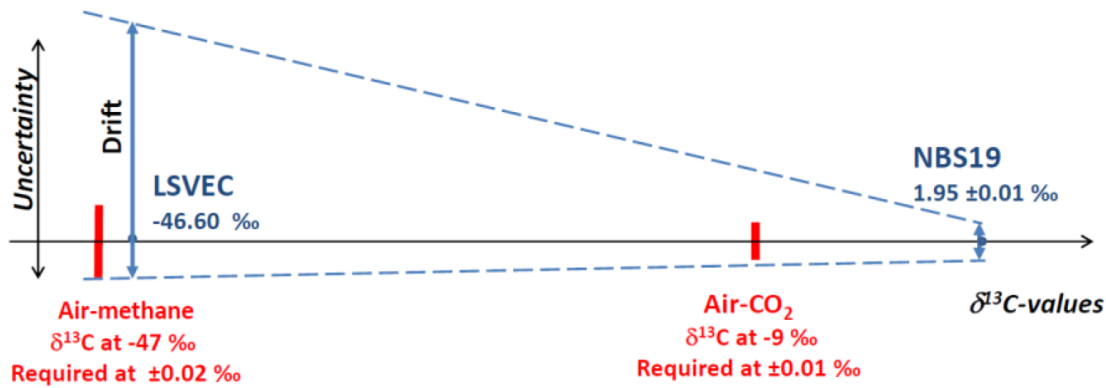
During extensive tests on IAEA-603, aliquots of LSVEC were analysed as a part of a RM monitoring programme. Significant scatter  $\delta^{13}\text{C}$  value was observed, both inside single LSVEC vials not in use (some material stratification) and on vial-to-vial basis. The question arose about the quality of LSVEC after 10 years of its introduction as the 2nd scale anchor. A systematic study of LSVEC at the IAEA yielded results demonstrating the  $\delta^{13}\text{C}$  scatter as following: (i) range of 0.25 ‰ between different vials not in use; (ii) scatter up to 0.20 ‰ on aliquots taken from 3 bulk-LSVEC containers stored at NIST. The total range observed on LSVEC is at least 0.3 ‰ (Figure 3). These IAEA results, independently confirmed at USGS and MPI-BGC, Jena, DE, imply that LSVEC no longer fulfils the requirements for the 2nd scale anchor RM.

The reason for this variability is thought to be adsorption of air moisture followed by a chemical sorption of air CO<sub>2</sub> ( $\delta^{13}\text{C} \sim -8.5$  ‰); the air CO<sub>2</sub> moves the LSVEC'  $\delta^{13}\text{C}$  to the positive direction, resulting in badly predicted  $\delta^{13}\text{C}$ -bias and vial-to-vial scatter. Additionally, some initial inhomogeneity of LSVEC cannot be excluded (Figure 3).



**Figure 3. Variability of  $\delta^{13}\text{C}$  values found on the various LSVEC aliquots. The  $\delta^{13}\text{C}$  scale given is not 2-point normalised.**

As calibrations for  $\delta^{13}\text{C}(\text{air-CO}_2)$  and  $\delta^{13}\text{C}(\text{air-CH}_4)$  by stable-isotope CCL (Central Calibration Laboratory) have to be based on the 2-point  $\delta^{13}\text{C}$ -calibration based on NBS19/LSVEC (Figure 2), the calibrations, the data uncertainty and data compatibility all appear to be affected (Figure 4). The actual magnitude of the effect and the increase in the calibration uncertainty have to be addressed by careful re-analysis of the calibration schemes at the CCL.



**Figure 4. The drift and thus enlarged uncertainty found for LSVEC (components such as RMs' inhomogeneity and alterations due to storage) may affect the data quality and data compatibility. The data compatibility goals are shown in red; the picture is not to scale.**

#### 4. The IAEA strategy on $\delta^{13}\text{C}$ reference materials addressing the needs of atmospheric monitoring

- The IAEA produces and distributes the highest-level RMs for stable isotope analyses which are used to calibrate stable isotope measurements for atmospheric monitoring. The homogeneity and stability of the highest level RMs should address the compatibility goals for atmospheric monitoring data. The homogeneity of IAEA-603 (replacement for  $\delta^{13}\text{C}$  scale-defining RM NBS19) is expected to be better than 0.01 ‰. The first batch of 5000 units (0.5g) is sealed in glass ampoules; RM characterisation will be finalised in 2016.
- Large  $\delta^{13}\text{C}$ -scatter (at least 0.3 ‰) was observed on LSVEC from different vials and different sources. It is concluded that LSVEC no longer fulfils the requirements for the highest-level RM; LSVEC is temporarily withdrawn from sales at the IAEA. As the next step, LSVEC has to be replaced by another material; its homogeneity should be such that any aliquot taken for calibration would be within  $\leq 0.02$  ‰ of the  $\delta^{13}\text{C}$  value assigned. Finding a proper replacement for LSVEC will have a high priority.
- In addition to the highest level  $\delta^{13}\text{C}$ -RMs in the form of carbonates, IAEA will explore a test-project on RMs in the form of pure gases to be made available in easy-to-use containers; these RMs will include a family of  $\text{CO}_2$  gases (covering range of  $\delta^{13}\text{C}$ ) and later to be expanded to  $\text{CH}_4$  and  $\text{N}_2\text{O}$ . Such RMs in the form of gases are thought to be useful for everyday calibrations (no preparation required) also for optical isotope analysers, given that a dilution set-up will be available at the users' labs.

#### References

1. Wang, X.H. et al., 2014: A two-fold increase of carbon cycle sensitivity to tropical temperature variations, *Nature*, 506(7487): p. 212-+.
2. Piao, S. et al., 2008: Net carbon dioxide losses of northern ecosystems in response to autumn warming, *Nature*, 2008. 451(7174): p. 49-U3.

3. WMO, 2013: *GAW Report No. 213. 17th WMO/IAEA Meeting on Carbon Dioxide, Other Greenhouse Gases and Related Tracers Measurement Techniques (GGMT-2013)*. (Beijing, China, 10-13 June 2013). World Meteorological Organization, Geneva, Switzerland.
  4. Coplen, T.B., et al., 2006: *After two decades a second anchor for the VPDB delta C-13 scale*. *Rapid Communications in Mass Spectrometry*, 20(21): p. 3165-3166.
  5. Coplen, T.B. et al., 2006: *New guidelines for delta C-13 measurements*, *Analytical Chemistry*, 78(7): p. 2439-2441.
-

## AMAZON BASIN: AN IMPORTANT SOURCE OF METHANE?

Luana S. Basso<sup>1,2</sup>, Luciana V. Gatti<sup>1,3</sup>, Caio S.C. Correia<sup>1,3</sup>, Lucas G. Domingues<sup>1,3</sup>, Viviane F. Borges<sup>1</sup>, Ricardo S. dos Santos<sup>2</sup>, Wellison R. Costa<sup>2</sup>, John B. Miller<sup>4</sup> and Emanuel U. Gloor<sup>2</sup>

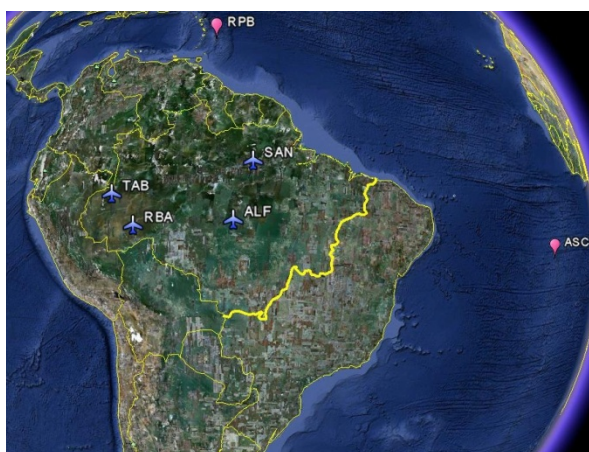
1. Instituto de Pesquisas Energéticas e Nucleares – IPEN/USP, São Paulo/SP, Brazil
2. University of Leeds, Leeds, United Kingdom
3. Instituto Nacional de Pesquisas Espaciais – INPE/CCST, São José dos Campos/SP, Brazil
4. National Oceanic and Atmospheric Administration – NOAA, Boulder, Colorado, USA

### 1. Introduction

Methane is the second most important anthropogenic greenhouse gas, with natural and anthropogenic sources<sup>1</sup>. Emissions from wetlands are considered the main natural global CH<sub>4</sub> source, around 32% of total emissions, and this source, over the past three decades, have dominated the variability from year to year in surface emissions<sup>2</sup>. Tropical land regions have until recently been poorly observed with large-scale integrating in-situ observations. Considering that the Amazon Basin represents 50% of the world tropical rainforest and CH<sub>4</sub> the importance of a greenhouse gases, contributing with around 18% to radiative forcing, and in 2014 the CH<sub>4</sub> mixing ratio increases of 9 ppb in comparison with the previous year, reaching 1833 ppb<sup>3</sup>, is important understand the contribution of the Amazon Basin in relation to this greenhouse gas. Then, observing the global importance of CH<sub>4</sub> and uncertainties in the emission of this greenhouse gases this study aimed to determine CH<sub>4</sub> emission in the Amazon Basin.

### 2. Methodology

CH<sub>4</sub> atmospheric measurements were started with vertical profiles using small aircrafts, since 2010 in Santarem (SAN: 02.8°S; 54.9°W), Rio Branco (RBA: 9.3°S, 67.6°W), Alta Floresta (ALF: 8.8°S, 56.7°W) and Tabatinga (TAB: 5.9°S, 70.1°W), all these sites located in Brazilian Amazon Basin (Figure 1).



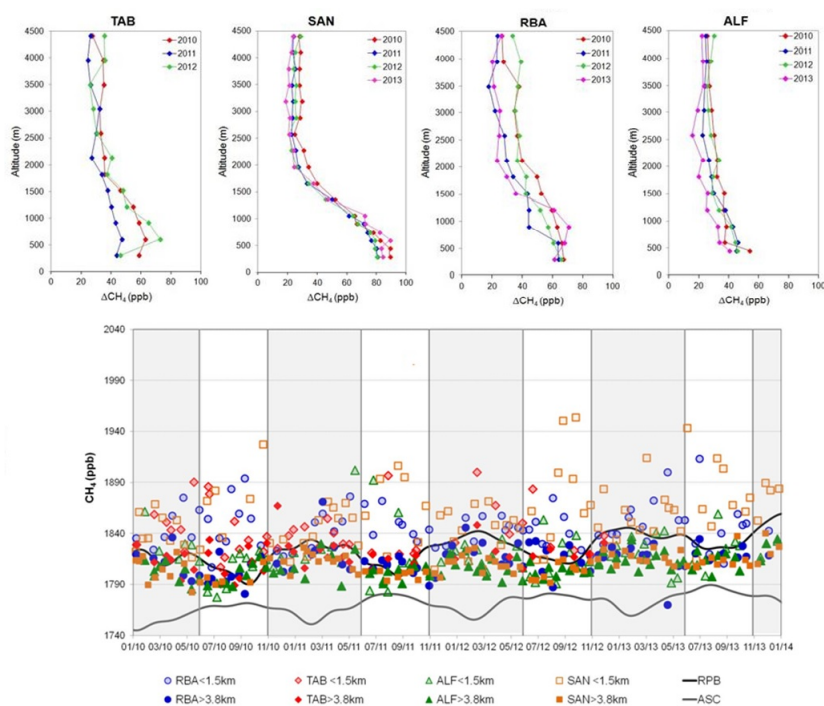
**Figure 1. Sample sites located in Brazilian Amazon and NOAA stations**

Samples from vertical profiles were collected, generally fortnightly, using a semi-automatic sampling system, which consists of separate compressor and flask units, developed by ESRL/NOAA. The first unit contains two rechargeable batteries and compressors, and remains at the sampling site. The second unit containing 17 glass flasks (used in SAN) or 12 flasks (used in ALF, RBA and TAB), a microprocessor that controls the sampling and storage of information about its conditions. Small aircraft were used for collecting, in which were installed

a collector tube (inlet), a temperature and relative humidity sensor and GPS (Global Positioning System) to record the position and altitude of each sample. Samples were taken between 12 pm and 2 pm local time, a period of greater stability in the troposphere, and therefore with better repeatability of atmospheric conditions, where the height of the boundary layer is close to its maximum height. The inlet was connected to the compressor unit that transfers the air to the unit containing the flasks which was connected to a device, called the pilot's display, indicating the pre-programmed altitude determined to sample the first to the last flask. The trajectory of the airplane was made in descending helical profile with a diameter of around 5 km, so there is no influence of the gas emitted by the engine of the aircraft in the sampling, starting at 4420 m and finishing at 427 m in ALF, 308 m in RBA, SAN and TAB. The quantification in this study uses a Column Integration Technique, were determined the flux for each flight by subtracting the observations from a measured background. This difference is the contribution in the CH<sub>4</sub> flux from the coast to the sample sites. The CH<sub>4</sub> background was determined using co-measured SF<sub>6</sub>, as a transport tracer, from the sample sites and two NOAA/ESRL background sites located in the Atlantic Ocean, Ascension Island (ASC, 8°S, 14°W) and Barbados (RBP, 12°S, 59°W). SF<sub>6</sub> allowed us to calculate the fractions of air arriving from the Northern and Southern Hemisphere at the sample sites.

### 3. Results and Discussion

We will present in this study results of 293 vertical profiles distributed in four sites in Amazon Basin, between 2010 and 2013, these results will allow us to analyze regional and temporal variability.



**Figure 2. (above) Annual mean  $\Delta\text{CH}_4$  (mean mole fraction vertical profile minus the background mole fraction) vertical profiles temporal and (below) temporal series for all sites above 3.8 km and below 1.5 km, the grey bars represent the wet season in Amazon region.**

The difference between the mole fraction at the sampling site and background mole fractions is a simple way to observe terrestrial sources and sinks and is directly related to terrestrial CH<sub>4</sub> fluxes (Miller et al., 2007). The lower levels of the profiles (within the planetary boundary layer, below around 1.5 km) are the parts most influenced by the process that occurs in the surface. Figure 2 shows enhancements in these lower altitudes, for the four samples sites, in comparison with the higher altitudes, indicating significant emissions in Amazon Basin. At higher altitude CH<sub>4</sub> levels are well-mixed, thus are likely representative of the CH<sub>4</sub> background air entering the basin. Indeed mean concentrations above 3.8 km (altitudes with less variability which represent the free troposphere) are usually between the ASC and RPB concentrations, like the

estimated background concentrations. The higher mean concentrations below 1.5 km compared with the mean above 3.8 km is a clear indication that the Amazon Basin is a source of CH<sub>4</sub> during the whole year. Comparing profiles of each site can be observed that SAN



showed a higher increasing in the lower altitudes of profiles compared with others sites, indicating higher CH<sub>4</sub> emissions in this region, suggesting a regional variation in CH<sub>4</sub> emissions. The annual mean of  $\Delta\text{CH}_4$  profiles shows a small indication of annual variability in the emissions, that can be correlated with climatologic factors.

#### 4. Conclusions

The results showed that the Amazon Basin was a source of CH<sub>4</sub> during the study period, but the CH<sub>4</sub> emission variable in the different regions and small variability with the years, these can be related with the climatological variations, 2010 and 2012 was driers years and 2011 and 2013 was wet years. With these results is possible to observe the importance of conducting studies on a regional scale to elucidate the behavior of the entire Amazon Basin. And the importance of long-term studies due the variation in emissions year by year, so that the results can be assumed to average behavior a long time series is necessary to take into account the methane balance from the Amazon Basin.

#### Acknowledgments

FAPESP, NERC, CNPq, MCTI, NOAA and IPEN

#### References

- <sup>1</sup>IPCC Intergovernmental Panel on Climate Change - Climate Change 2013: The Physical Science Basis. Contribution of Working Group I to the Fifth Assessment Report of the Intergovernmental Panel on Climate Change [Stocker, T.F., D. Qin, G.-K. Plattner, M. Tignor, S.K. Allen, J. Boschung, A. Nauels, Y. Xia, V. Bex and P.M. Midgley (eds.)]. *Cambridge University Press*, Cambridge, United Kingdom and New York, NY, USA, 1535 pp, 2013, ISBN 9781107661820.
- <sup>2</sup>Kirschke, S., P. Bousquet, P. Ciais, M. Saunois, J.G. Canadell, E.J. Dlugokencky, P. Bergamaschi, D. Bergmann, D.R. Blake, L. Bruhwiler, P. Cameron-Smith, S. Castaldi, F. Chevallier, L. Feng, A. Fraser, P.J. Fraser, M. Heimann, E.L. Hodson, S. Houweling, B. Josse, P. B. Krummel, J.F. Lamarque, R. L. Langenfelds, C. Le Quéré, V. Naik, S. O'Doherty, P. I. Palmer, I. Pison, D. Plummer, B. Poulter, R. G. Prinn, M. Rigby, B. Ringeval, M. Santini, M. Schmidt, D. T. Shindell, I. J. Simpson, R. Spahni, L.P. Steele, S.A. Strode, K. Sudo, S. Szopa, G.R. van der Werf, A. Voulgarakis, M. van Weele, R.F. Weiss, J.E. Williams, G. Zeng, 2013: Three decades of global methane sources and sinks, *Nature Geoscience*, 6, 813–823, 2013, doi:10.1038/ngeo1955.
- <sup>3</sup>WMO, 2015: World Meteorological Organization. Greenhouse Gas Bulletin - The state of Greenhouse gases in the atmosphere using global observation through 2014. n. 11.

## STUDY OF SF<sub>6</sub> MOLE FRACTIONS IN AMAZON BASIN AND BRAZILIAN COAST

Luana S. Basso<sup>1,2</sup>, Luciana V. Gatti<sup>1,3</sup>, Viviane F. Borges<sup>1</sup>, Caio S.C. Correia<sup>1,3</sup>, Lucas G. Domingues<sup>1,3</sup>, Ricardo S. dos Santos<sup>2</sup>, Wellison R. Costa<sup>2</sup>, John B. Miller<sup>4</sup> and Emanuel U. Gloor<sup>2</sup>

1. Instituto de Pesquisas Energéticas e Nucleares – IPEN/USP, São Paulo/SP, Brazil
2. University of Leeds, Leeds, United Kingdom
3. Instituto Nacional de Pesquisas Espaciais – INPE/CCST, São José dos Campos/SP, Brazil
4. National Oceanic and Atmospheric Administration – NOAA, Boulder, Colorado, USA.

### 1. Introduction

SF<sub>6</sub> is one of the most potent greenhouse gases known. Its surface fluxes include anthropogenic emissions from applications in industry and very minor uptake by the oceans. SF<sub>6</sub> is inert throughout the troposphere and stratosphere and is slowly photolyzed in the mesosphere, resulting in an estimated atmospheric lifetime of 3200 years<sup>1</sup>. Due its very long lifetime, SF<sub>6</sub> emissions are accumulating in the atmosphere<sup>2</sup>. Its global mole fraction increased nearly linearly in recent decades and in 2014 is about twice the level observed in the mid-1990s<sup>3</sup>.

Brazilian SF<sub>6</sub> emissions were estimated at 25.2 tons in 2005, of which 24% (6.13 tons) came from electrical equipment emissions, due to loss in equipment, especially during maintenance or disposal. And 76% (19.5 tons) are emissions from the production of magnesium, where SF<sub>6</sub> is used to prevent oxidation of the metal in its liquid phase. Between 1990 and 2005, Brazil emissions of SF<sub>6</sub> increased 153%.<sup>4</sup> Between 2005 and 2010, SF<sub>6</sub> Brazilian emissions decreased due to substitution using this gas in magnesium production by SO<sub>2</sub>, and in 2010 Brazilian emissions was 7.4 tons<sup>5</sup>. According to the EDGAR database<sup>6</sup>, Brazilian emissions for 2005 were 51.2 tons, which corresponds to 0.8% of the global emission estimate for this year (6033.7 tons). Our interest in SF<sub>6</sub> mole fractions is to use this gas as a transport tracer to calculate CO<sub>2</sub>, CH<sub>4</sub> and N<sub>2</sub>O fluxes over the Amazon Basin.

### 2. Methodology

SF<sub>6</sub> atmospheric measurements were started with vertical profiles using small aircrafts, since 2000 in Santarem (SAN: 02.8°S; 54.9°W), 2009 in Rio Branco (RBA: 9.3°S, 67.6°W), 2010 in Alta Floresta (ALF: 8.8°S, 56.7°W) and Tabatinga (TAB: 5.9°S, 70.1°W), all these sites located in Brazilian Amazon Basin (Figure 1). Since 2010, we started flask measurements at two sites located at the Brazilian Atlantic coast (Figure 1): in Salinópolis (SAL: 0.6°S, 47.4°W) and in Natal (NAT: 5.5°S, 35.2°W). Samples from vertical profiles were collected, generally fortnightly, using a semi-automatic sampling system, which consists of separate compressor and flask units, developed by ESRL/NOAA. The first unit contains two rechargeable batteries and compressors, and remains at the sampling site. The second unit containing 17 glass flasks (used in SAN) or 12 flasks (used in ALF, RBA and TAB), a microprocessor that controls the sampling and storage of information about its conditions. Small aircraft were used for collecting, in which were installed a collector tube (inlet), a temperature and relative humidity sensor and GPS (Global Positioning System) to record the position and altitude of each sample. Samples were taken between 12 pm and 2 pm local time, a period of greater stability in the troposphere, and therefore with better repeatability of atmospheric conditions, where the height of the boundary layer is close to its maximum height. The inlet was connected to the compressor unit that transfers the air to the unit containing the flasks which was connected to a device, called the pilot's display, indicating the pre-programmed altitude determined to sample the first to the last flask. The trajectory of the airplane was made in descending helical profile with a diameter of around 5 km, so there is no influence of the gas emitted by the engine of the aircraft in the sampling, starting at 4420 m and finishing at 427 m in ALF, 308 m in RBA, SAN and TAB.



**Figure 1. Sample sites located in Brazilian Amazon and Brazilian coast**

The surface air sampling were collected in the two localities along the Brazilian coast (NAT and SAL), generally weekly, using glass flasks of 2.5 liters of volume being sampled in pairs and in series, and its comparison represents a quality control sample. In the first step is passed around 50 liters of air (5 L/min) for cleaning and conditioning of the flasks, ending the sampling with 6 psi pressure above atmospheric pressure. A Teflon tube is used to the sampling and elevated for at least five meters high above the location of the sampler.

### 3. Results and Discussion

Between the years 2000 and 2009 around 100 profiles were made in SAN, and since 2010 293 more vertical profiles distributed over four locations in the Brazilian Amazon Basin, ALF, RBA, SAN and TAB. Between 2010 and 2013 347 surface samples were collected in SAL and NAT. Consistent with other existing records our SAN results show that SF<sub>6</sub> mole fractions increased since 2000, by nearly 3.3 ppt (72%) between 2000 and 2013, and by a mean increase rate of 0.26 ppt per year.

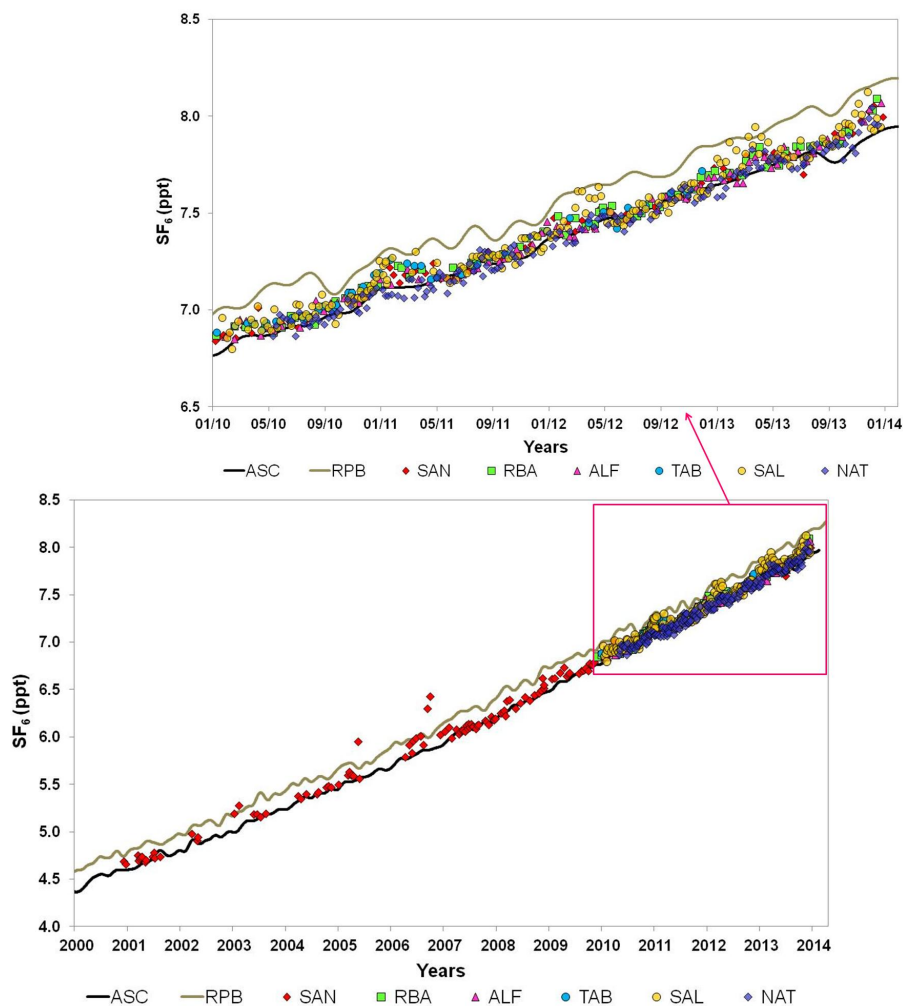
Figure 2 shows the results obtained during 2010 until 2013 in the six sampling sites, and the SF<sub>6</sub> mean mole fractions from the Ascension (ASC: 7.92°S, 14.42°W) and Barbados (RPB: 13.17°N, 59.43°W) NOAA stations, representing the Southern and Northern Hemisphere, respectively, for this period. It was observed during the 4 years study (2010-2013), that mole fractions at all our stations are generally similar to other ASC (Southern Hemisphere) records with the exception of the January to beginning of May for SAL, SAN, RBA, ALF and TAB, when mole fractions are higher than the other months, and more similar to RPB (Northern Hemisphere) records (Figure 2). Examination of air parcel paths using HYSPLIT<sup>7</sup> for these periods confirmed that some air parcels arriving at these stations have travelled from the Northern Hemisphere to the sites. The mean position of Intertropical Convergence Zone (ITCZ) shows variation along the year. Between January and beginning of May the ITCZ is below SAL position, therefore the air masses for SAL and Amazon Basin sites coming from North Hemisphere. The air masses back trajectories calculated for NAT show that the air masses arriving entirely from the South Atlantic Ocean, and the SF<sub>6</sub> mole fractions obtained in NAT showed similar behavior as ASC (Southern Hemisphere) mean mole fraction (Figure 2). The mean mole fractions obtained for study sites are shown in Table 1, it was observed that in all sites SF<sub>6</sub> mole fractions showed an increase over the previous year. Finally there are no significant differences between coastal and inland stations confirming the absence of SF<sub>6</sub> sources in the Basin, because SF<sub>6</sub> mole fractions of ALF, RBA, SAN and TAB are closer to the SAL mole fractions.

In NAT existed a comparison of air in flask pairs sampled weekly and analysed by IPEN and NOAA/ESRL (pairs taken within 30 min of each other) has been in operation since September 2010. Between 2010 and 2013 was compared 139 samples and the mean difference between these laboratories was  $0.017 \pm 0.07$  ppt, where 70% varies between 0 and 0.05 ppt.

**Table 1. SF<sub>6</sub> annual mean mole fractions to Amazon Basin sites and Brazilian coast**

year	SF <sub>6</sub> mean concentration (ppt)					
	NAT	SAL	ALF	RBA	SAN	TAB
2007	-	-	-	-	6.11 ± 0.05	-
2008	-	-	-	-	6.38 ± 0.12	-
2009	-	-	-	-	6.72 ± 0.08	-
2010	6.98 ± 0.06*	6.98 ± 0.07	6.98 ± 0.09	6.99 ± 0.08	6.95 ± 0.09	7.00 ± 0.09
2011	7.18 ± 0.09	7.25 ± 0.06	7.25 ± 0.09	7.27 ± 0.07	7.24 ± 0.07	7.24 ± 0.06
2012	7.50 ± 0.09	7.54 ± 0.07	7.52 ± 0.09	7.53 ± 0.09	7.53 ± 0.09	7.60 ± 0.08
2013	7.84 ± 0.17	7.83 ± 0.11	7.82 ± 0.11	7.84 ± 0.10	7.84 ± 0.11	-

\*Mean between May and December 2010



**Figure 2. SF<sub>6</sub> temporal series for all sites in the Brazilian Coast and Amazon Basin, between 2000 and 2013, highlight the period between 2010 and 2013.**

#### 4. Conclusions

The SF<sub>6</sub> mole fractions measured in the SAN site have a significant increase between 2000 and 2013 (72%), following the observed increase in the global mixing ratio. All SF<sub>6</sub> mole fractions measured in our sites (Brazilian Amazon Basin and coast sites) have values, in the majority, similar to ASC (Southern Hemisphere) mean mole fractions, but in the beginning of the year have values close to the RPB (Northern Hemisphere), due the position of ITZC. Comparison between Amazon Basin and Brazilian coast sites showed that have not SF<sub>6</sub> emissions in the study area.

#### Acknowledgments

FAPESP, NERC, CNPq, MCTI, NOAA and IPEN

#### References

- <sup>1</sup>Ravishankara, A.R.; S. Solomon, A.A. Turnispeed and R.F. Warren, 1993: Atmospheric lifetime of long-lived halogenated species, *Science*, 259, 194–199.
  - <sup>2</sup>IPCC - Intergovernmental Panel on Climate Change. Climate Change 2007: The Physical Science Basis. Contribution of Working Group I to the Fourth Assessment Report of Intergovernmental Panel on Climate Change. Solomon, S.; Qin, D.; Manning, M.; Marquis, M.; Averyt, K.; Tignor, M.M.B.; Miller Jr, H.L.; Chen, Z., *Cambridge University Press*, Cambridge, 2007.
  - <sup>3</sup>WMO – World Meteorological Organization. Greenhouse Gas Bulletin, 2015: - The state of Greenhouse gases in the atmosphere using global observation through 2014. n. 11.
  - <sup>4</sup>MCT - Ministério da Ciência e Tecnologia, 2010: Segunda Comunicação Nacional à Convenção-Quadro das Nações Unidas sobre Mudança do Clima. Brasília.
  - <sup>5</sup>MCT - Ministério da Ciência e Tecnologia, 2013: Estimativas anuais de emissões de gases de efeito estufa no Brasil. Brasília.
  - <sup>6</sup>European Commission, Joint Research Centre (JRC)/Netherlands Environmental Assessment Agency (PBL), 2009: Emissions Database for Global Atmospheric Research (EDGAR), release version 4.0. <<http://edgar.jrc.ec.europa.eu>>
  - <sup>7</sup>Draxler, R.R. and G.D. Rolph, 2013: HYSPLIT (HYbrid Single-Particle Lagrangian Integrated Trajectory) Model access via NOAA ARL READY Website: (<http://ready.arl.noaa.gov/HYSPLIT.php>), NOAA Air Resources Laboratory, Silver Spring, MD.
-

## AMAZON AND COAST BRAZILIAN GREENHOUSE GAS MEASUREMENT PROGRAMME AND THE EFFORTS IN CONSTRUCTING THE GHG NETWORK

L.V. Gatti<sup>1,2</sup>, J.B. Miller<sup>3</sup>, M. Gloor<sup>4</sup>, L.G. Domingues<sup>1,2</sup>, C.S.C. Correia<sup>1,2</sup>, V.F. Borges<sup>1,2</sup>, L.S. Basso<sup>1,4</sup>, M. Gomes<sup>2</sup>, W.R. Costa<sup>1,2</sup>, R.S. Santos<sup>1,2</sup>, P. Alvalá<sup>2</sup>, J. Ometto<sup>2</sup>, H. Boesch<sup>5</sup> and O. Moraes<sup>6</sup>

1. Atmospheric Chemistry Laboratory, Nuclear and Energy Research Institute, IPEN-CNEN/SP, Brazil
2. Instituto Nacional de Pesquisas Espaciais-INPE/CCST, São José dos Campos/SP, Brazil
3. ESRL, NOAA, Boulder, United States
4. University of Leeds, Leeds, United Kingdom
5. EOS Group, Department of Physics and Astronomy, University of Leicester
6. MCTI/SEPED – Ministerio da Ciencia e Tecnologia e Inovação, Brasil

### 1. Introduction

Tropical land is a very poorly constrained component of the carbon cycle, although it is potentially very important because it hosts a very large fast releasable carbon pool in forests and soils potentially amenable to feedbacks with climate. The tropics are a poorly constrained component because until recently there have been very few lower troposphere greenhouse gas measurements that are regionally representative. Amongst the tropical land regions the Amazon is by far the largest and also hosting the largest carbon pools around 200 PgC. The greenhouse gas (GHG) monitoring activities conducted by IPEN - LQA (Atmospheric Chemistry Laboratory) over Amazonia are briefly documented, especially focusing on the new development in the past 3 years. We report here a complete picture from the GHG vertical profiles measures, long-term programme, distributed in the 4 sites to represent entire Amazon Basin started January 2010 and performed by IPEN/LQA group.

This aircraft measurement programme over the Amazon Basin it is a results of collaboration with many groups and with funds from many projects. The participant institutions and groups are: IPEN/CQMA/LQA, Universities of Leeds, NOAA/ESRL/GMD, University of Sao Paulo, Leicester, Colorado, Centro Euro-Mediterraneo per i Cambiamenti Climatici, etc. and funds from many Agencies and projects (NERC (53%), FAPESP (26%), 7FP EC (11%) and MCTI/CNPq (10%)). In parenthesis the fund participation from each agency in this programme.

With the goal of building The Brazilian Greenhouse Gas Network we changed the Atmospheric Chemistry Laboratory (LQA) from IPEN to INPE in order to join two Brazilian groups to build the National GHG Laboratory and improve conditions to build the Brazilian network. In October it will be a workshop to define the structure of this network, based on the experience that we already have in action in Brazil and guests from other networks (NOAA and IGOS) that will bring their experiences to us.

#### 1.1 Aircraft measurement sites in Brazil

The aircraft measurement programme was started in 2000 with monthly/biweekly vertical profile sampling at SAN (2.86S 54.95W) funded by NASA. In 2010, a new step in our measures programme was started. We added three more aircraft sites: TAB (5.96S 70.06W), RBA (9.38S 67.62W) and ALF (8.80S 56.75W). During 2010, 2011, 2012, we performed 233 vertical profiles from 300m to 4400m above sea level, measuring CO<sub>2</sub>, CH<sub>4</sub>, N<sub>2</sub>O, CO and SF<sub>6</sub> on WMO mole fraction scales. In 2013 we add two more sites were started in our programme with profiles from 300m to 7.3 km, at Salinópolis (SAH 0.60S; 47,37W), near the Atlantic coast and RBH at the same place then RBA, in the western Amazon (Figure 1). These profiles will be useful to compare and validate satellite measurements over Amazonia and other important objective with these high profiles is to answer one important question about what

information we are losing above 4.4km height and what is the concentration distribution between 4.4 and 7.3 km.



**Figure 1. Four aircraft sites TAB, RBA, ALF, SAN (0.3 to 4.4km) until 2010 and more two sites until 7.3 km RBA and SAL with three coast sites SAL, CAM and NAT. TEF is the substitute of TAB site.**

The analyses were made in a replica of NOAA GHG analysis system (MAGICC), installed in Brazil, São Paulo, in IPEN/CQMA/LQA. We follow the recommendations for quality assurance control and participating in the inter-comparison Roding Robin and a weekly programme between NOAA/GMD and IPEN at NAT to guaranty the accuracy of results.

In all of the profiles  $\text{CO}_2$ ,  $\text{CH}_4$ ,  $\text{N}_2\text{O}$ ,  $\text{CO}$  and  $\text{SF}_6$  were measured on between 12 and 17 flask samples, depending on site (Figure 1 aircrafts and coast sites).

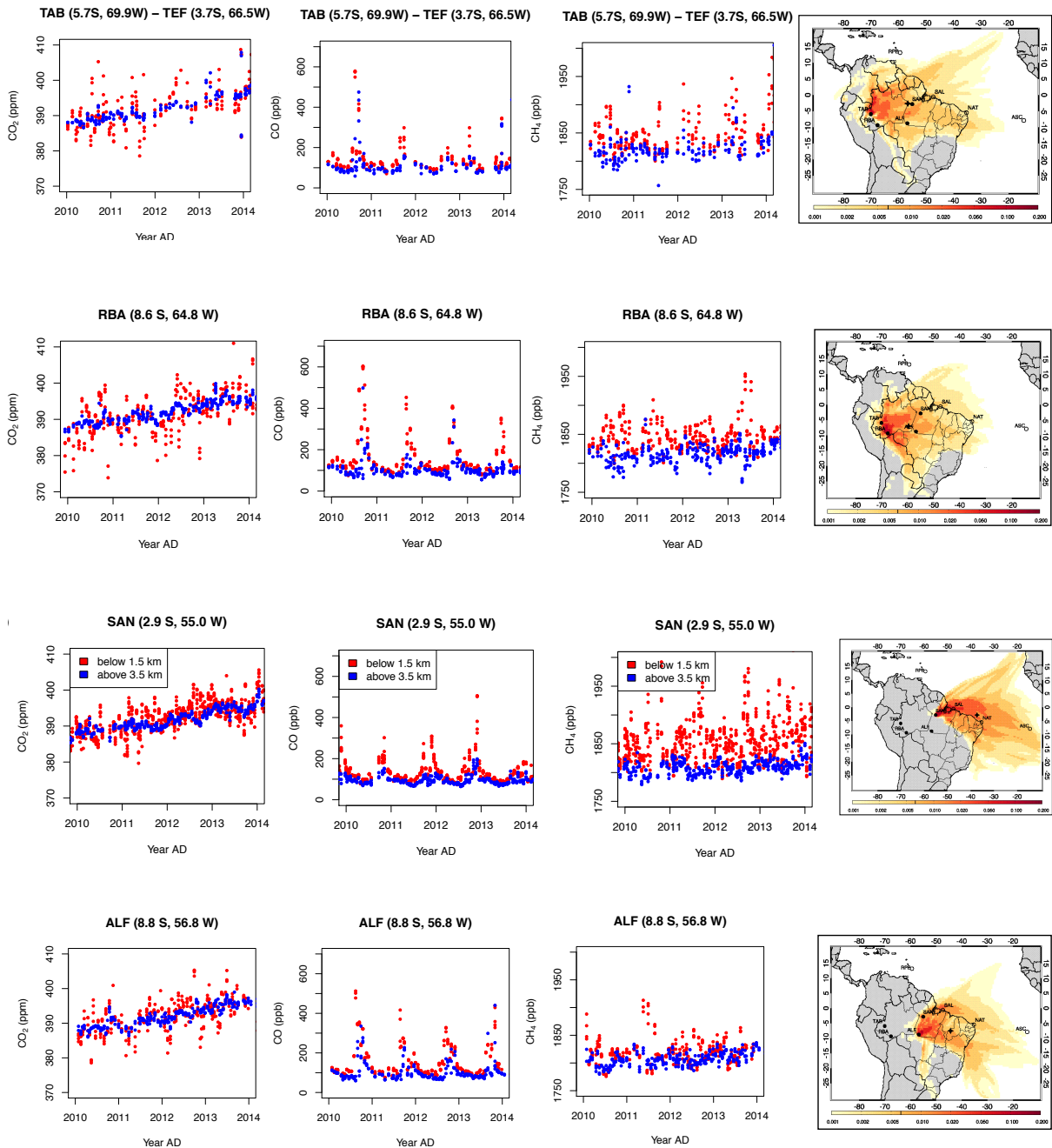
## 2. Measurement methodology

Air was collected with portable sampling systems consisting of separate compressor and flask units (Tans et al., 1996). GPS and temperature and relative humidity sensors have also been attached to the compressor unit. We used 2 flask units: one contains 17 (SAN) flasks and other 12 (RBA, TAB and ALF) with each 700 mL and pressurized to about 270 kPa. The flights consisted of one descending profile from 4500 m to 300 m. Profiles were usually taken between 12-14h local time, because this is the time when the boundary layer is close to being fully developed. The profiles are made 2 times per month in the four places and in the two coast stations the sample is weekly. The locations for aircraft stations are: SAN (running since 2000), RBA (since Dec 2009), ALF (since Jan 2010), TAB (since Jan 2010 to 2012) and TEF (starting 2013) The actual two coast stations in Brazil: SAL (since Jan 2010) and NAT (since may 2010). The RBH site started too a new step in our aircraft programme using a compressed airplane, where we used a new technology for inlet and other sensors installation. Coastal studies are conducting actually at 3 sites: SAL (started 2010), NAT (started 2010) and CAM (started 2014). Since 2010 until 2014, we performed 400 vertical profiles from 300m to 4400m above sea level, measuring  $\text{CO}_2$ ,  $\text{CH}_4$ ,  $\text{N}_2\text{O}$ ,  $\text{CO}$  and  $\text{SF}_6$  on WMO mole fraction scales. SAN is the longest time series, where it was performed 221 vertical profiles since 2000.

## 3. Results and discussion

Taking advantage of the consistent trade winds that enter Amazonia from the Atlantic coast, a column integration technique is used to calculate fluxes for all gases (Miller et al, 2007;

D'Amelio et al., 2009 and Gatti et al, 2010 and 2014). This technique implicitly accounts for emissions resulting from all biosphere-atmosphere exchange processes between the site and the coast, excepting some "leakage" of surface signal (via convection) above 4.5 km asl. From Figure 2, it is clear that RBA, TAB and ALF, during the wet season (generally December to June), are near neutral due to mean profile being between the background ASC and RPB mole fractions. But sometimes we can see clearly uptake by the forest, because the profile mean is lower than ASC and RPB mole fractions. During the dry season, the profile mean is higher than ASC and RPB. In Amazonia, the biomass burning season happens at this time, where it is more intense during the period between August to October.



**Figure 2. Time series for the sites (TAB/TEF, RBA, SAN and ALF), where red points is the mean concentration below PBL (<1.5 km height) in the vertical profiles and blue points is the mean above 3.5 km height. In the right side is the footprint area for each site calculated by Flexpart modelling.**



#### 4. Conclusions

The efforts to construct a Brazilian network are very important because of the great importance of Amazonia in understanding, and eventually predicting, the global carbon cycle and its feedbacks with climate. We observed a very strong climate parameters in Carbon Balance.

#### Acknowledgments

NOAA, NERC, FAPESP, Marinha do Brasil, INPE/CRN, CNPq, CAPES, IPEN, MCT/Brazilian Government.

#### References

- BRASIL - Ministério da Ciência e Tecnologia. Coordenação-Geral de Mudanças Globais de Clima, 2010. Segunda Comunicação Nacional do Brasil à Convenção-Quadro das Nações Unidas sobre Mudança do Clima. Brasília: MCT. 280p.
- D'Amelio, M.T.S., L.V. Gatti, J. Miller and P. Tans, 2009: Regional N<sub>2</sub>O fluxes in Amazonia derived from aircraft vertical profiles. *Atmospheric Chemistry and Physics* (Online), v.9, p.8785-8797, 2009.
- Gatti, L.V., M. Gloor, J.B. Miller, C.E. Doughty, Y. Malhi, L.G. Domingues, L.S. Basso, A. Martinewski, C.S.C. Correia, V.F. Borges, S. Freitas, R. Braz, L.O. Anderson, H. Rocha, J. Grace, O.L. Phillips and J. Lloyd, 2014: Drought sensitivity of Amazonian carbon balance revealed by atmospheric measurements, *Nature*, 506, 76-80, doi: 10.1038/nature12957.
- Gatti, L.V., J.B. Miller, M.T.S. D'Amelio, A. Martinewski, L.S. Basso, M.E. Gloor, S. Wofsy and P. Tans, 2010: Vertical profiles of CO<sub>2</sub> above eastern Amazonia suggest a net carbon flux to the atmosphere and balanced biosphere between 2000 and 2009. *Tellus, Series B, Chemical and Physical Meteorology*, v.62, p.581-594.
- Gloor M., L.V. Gatti, R. Brienen, T.R. Feldpausch, O.L. Phillips, J. Miller, J.P. Ometto, H. Rocha, T. Baker, Ben de Jong, S. Houghton, Y. Malhi, L.E.O.C. Aragão, J.-L. Guyot, K. Zhao, R. Jackson, P. Peylin, S. Sitch, B. Poulter, M. Lomas, S. Zaehle, C. Huntingford and J. Lloyd, 2011: The Carbon balance of South America: status, decadal trends and main determinants, *Biogeosciences*, 9, 627-671, 2012, [www.biogeosciences-discuss.net/9/627/2012/doi:10.5194/bgd-9-627-2012](http://www.biogeosciences-discuss.net/9/627/2012/doi:10.5194/bgd-9-627-2012).
- Miller, J., L.V. Gatti, M.T.S. D'Amelio, A. Croswell, E.J. Dlugokencky, P. Bakwin, P. Artaxo and P. Tans, 2007: Airborne samples indicate large methane emissions from the Eastern Amazon Basin. *Geophysical Research Letters*, v.34, p.L10809-.

## FOUR YEARS CARBON MONOXIDE VERTICAL PROFILES STUDY AT THE AMAZON BASIN

Lucas G. Domingues<sup>1,2</sup>, Luciana V. Gatti<sup>1,2</sup>, Afonso R. de Aquino<sup>1</sup>, Luana S. Basso<sup>1</sup>, Caio S. C. Correia<sup>1,2</sup>, Viviane F. Borges<sup>1</sup>, Ricardo S. dos Santos<sup>2</sup>, Wellison R. Costa<sup>2</sup>, Emanuel U. Gloor<sup>3</sup> and John B. Miller<sup>4</sup>

1. IPEN/CQMA/LQA (Nuclear and Energy Research Institute), Sao Paulo, SP, Brazil
2. INPE/CCST/LaGEE (National Institute of Space Research)
3. NOAA/ESRL/GMD (Global Monitoring Division), Boulder, Colorado, US
4. University of Leeds, School of Geography, UK

### 1. Introduction

The amazon rainforest is one of the main tropical forests in world, corresponding for 50% of this biome in the globe. It has a total area of, approximately, 8 million km<sup>2</sup>, which 5 million km<sup>2</sup> are in Brazil (58.74% of the total area in Brazil) and contains one quarter of global biodiversity (Malhi and Phillips, 2005). Possessing a high density of trees and consequently a large stock of carbon and nitrate, it is important to study the biomass burning in order to evaluate greenhouse gases emission. It's well known that the inhabitants of amazon rainforest have the habit of burning the existing forest to clear areas for soy production and others anthropogenic activity (Morton, et al. 2006).

The combustion happens following a sequence of stages (ignition, flaming, smoldering and extinction) and its evolution depends on fuel and environment characteristics. If the combustion process happens in an ideal manner the only products would be carbon dioxide (CO<sub>2</sub>) and water, but in a forest there are different stages and factors that compromise the efficiency of the fuel burn like humidity, wind, topography, meteorological conditions, water rate, among others, which results in an emission of other subproducts as Nitrous Oxide (N<sub>2</sub>O), Methane (CH<sub>4</sub>) and Carbon Monoxide (CO) (Leeuwen and Werf, 2011).

The CO gas has been used as atmospheric biomass burning tracer in different scales (van der Werf, 2004), thus the study of its concentration is an important tool to determine the real concentration and flux above the amazon basin of the greenhouse gases.

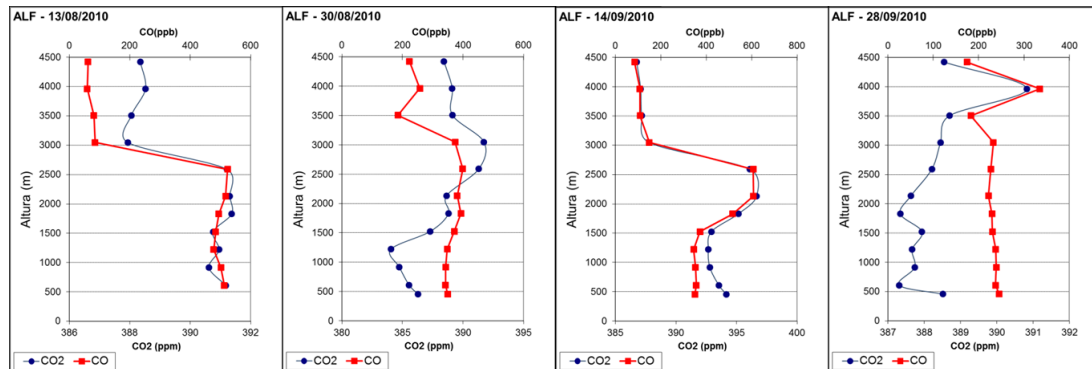
### 2. Methodology

During the years 2010, 2011, 2012 and 2013 were performed vertical profiles using small aircraft in altitudes between 300 and 4400m in four sites at the Amazon Basin: Santarém – Pará (SAN) (2° S, 54° W), Alta Floresta – Mato Grosso (ALF) (16° S, 56°W), Tabatinga – Amazonas (TAB) (4° S, 64°W) and Rio Branco – Acre (RBA) (10°S, 68° W). The samples were collected in situ during flights with a predetermined helicoidally trajectory to avoid the emission from the airplane and approach the position of the samples made in different altitudes. The measurements were performed between 12 and 14 o'clock, local time, because it is when the troposphere reaches its most stability state, which gives more repeatability of atmospheric conditions when the planetary boundary layer is near its maximum altitude. After this process (flight/sampling), the sampling unit were sent for analysis at Atmospheric Chemistry Laboratory (LQA).

To determine the greenhouse gases flux was used the method of integration column described by Miller et al. (2007). In this method the background concentration is subtracted from the concentration obtained in each profile sample and divided by the time that the air mass took to cross the continent until the sample site.

To calculate the background concentrations air fractions that arrived at sampling sites were used the Sulfur Hexafluoride (SF<sub>6</sub>) gas as an air masses tracer, because there is no production

of this gas through the area between the coast and the studied sites, so the obtained concentration on the profile is considered the same which entered into the continent. To evaluate the influence of biomass burning at the greenhouse gases (GHG) emissions, the CO was used as a tracer because of its behaviour in the dry season, when the burning happens, its concentrations increases by 2 to 4 times. Profiles of the dry season were carefully analyzed and separated the ones that clearly show the influence of the biomass burning at the GHG concentrations (Figure 1).



**Figure 1. Profiles with a clear correlation between CO and CO<sub>2</sub> that were used at the CO:CO<sub>2</sub> ratio calculation**

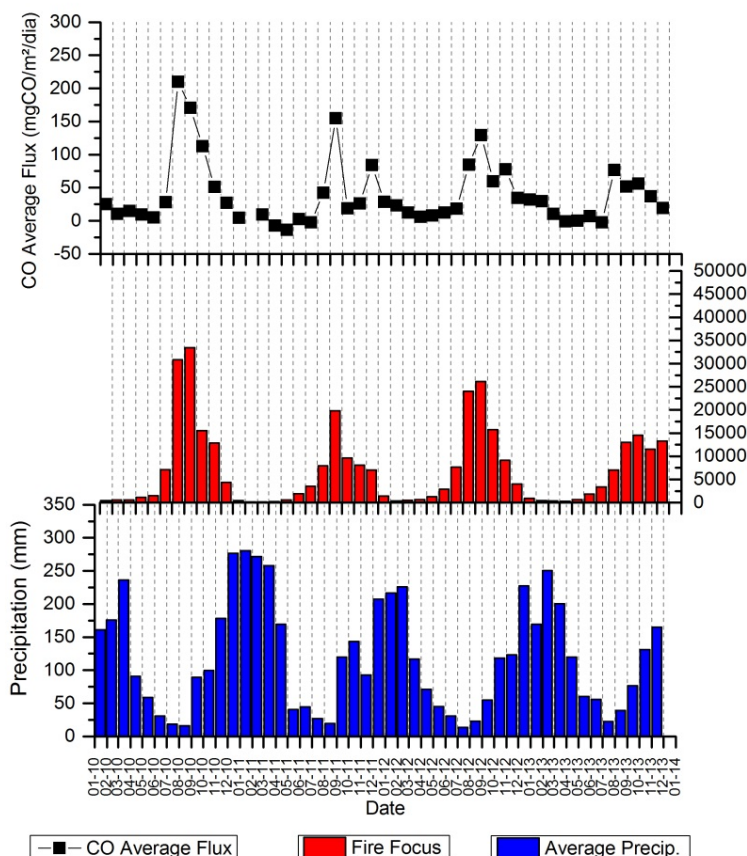
Afterwards was calculated the ratio CO:GHG to determine the burning contribution of GHG emissions. It was necessary to considerate a natural source by soil (CONRAD and SEILER, 1985) to remove only the biomass burning source. To simplify the method was assumed that the natural emissions were stable throughout the year.

### 3. Results and Discussion

At the four locations were identified a correlation between the CO flux, precipitation and counts of fire spots. In ALF (Figure 2), located at Arc of Fire (Arco do Fogo), was observed that the peak of CO emission coincides with the maximum of fire spots and precipitation decreases, thereby making evident the emission from the wet and dry season. This is the site where the highest concentrations of CO were observed and, unlike TAB and SAN, were determined a strong vertical mixing. At the sites, where there is a predominance of forest like TAB and RBA, the observed flux showed the same behaviour than ALF, however in a minor emission. SAN, located in the Amazon northeast region, receives a great influence of anthropogenic emissions from the northeast Brazil region. The relation between the concentrations of CO and CO<sub>2</sub> (carbon dioxide) in the profiles was performed, considering only the profiles with a clear plume to determine the emission ratio, where it was used only the portion of profile above 1.5km, approximately the PBL (Planetary Boundary Layer). The 3 sites with fewer anthropic impacts had similar ratio CO/CO<sub>2</sub>, in contrast to what was determined in Santarém.

### 4. Conclusions

ALF was the site which presented the highest burning flux in spite of CO losses for atmospheric reactions. RBA and TAB are located in areas with less local influence from biomass burning and this can interfere in the acquired data in opposition to SAN which is most affected for local influence.



**Figure 2. Site ALF time series for CO flux, fire focus and precipitation**

## Acknowledgments

FAPESP, NERC, CNPq, NOAA and IPEN.

## References

- Conrad R. and W. Seiler, 1985: Influence of temperature, moisture and organic carbon on the flux of H<sub>2</sub> and CO between soil and atmosphere: Field studies in subtropical regions, *Journal of Geophysical Research*, 90, 5699–5709.
- Malhi Y. and O. Phillips, 2005: Tropical forests and global atmospheric change, *Oxford University Press*.
- Miller, J.B., L.V. Gatti, M.T.S.C. D'Amelio, A. Crowell, E. Dlugokenky, P. Bakwin, P. Artaxo and P. Tans, 2007: Airborne measurements indicate large methane emissions from the eastern Amazon Basin, *Journal of Geophysical Research*, v. 34, p. L10809,
- Morton D.C., R.S. Defries, Y.E. Shimabukuro, L.O. Anderson, E. Arai, F.B. Espirito-Santo, R. Freitas and J. Morissette, 2006: *Cropland expansion changes deforestation dynamics in the southern Brazilian Amazon*.
- Van Leeuwen T.T. and G.R. Van der Werf, 2011: Spatial and temporal variability in the ratio of trace gases emitted from biomass burning, *Atmospheric Chemistry and Physics*.
- Van der Werf, G.R. 2004: Continental-scales partitioning of fire emissions during the 1997 to 2001 El Niño/La Niña Period. *Science*, v. 303(5654), p. 73-76.

## FIVE YEARS OF BRAZILIAN GREENHOUSE GASES BACKGROUND CONCENTRATIONS

Viviane F. Borges<sup>1</sup>, Luciana V. Gatti<sup>1,2</sup>, Lucas G. Domingues<sup>1,2</sup>, Caio S. C. Correia<sup>1,2</sup>, Luana S. Basso<sup>1,3</sup>, Ricardo S. Santos<sup>2</sup>, Wellison R. Costa<sup>2</sup>, Manuel U. Gloor<sup>3</sup> and John B. Miller<sup>4</sup>

1. Instituto de Pesquisas Energéticas e Nucleares–IPEN/USP, São Paulo/SP, Brazil
2. Instituto Nacional de Pesquisas Espaciais–INPE/CCST, São José dos Campos/SP, Brazil
3. University of Leeds, Leeds, United Kingdom
4. National Oceanic and Atmospheric Administration–NOAA, Boulder, Colorado, USA

### 1. Introduction

Tropical areas have been poorly represented in the actual global greenhouse gases (GHG) monitoring network. Based on this are necessary studies to understand the contribution of these areas, mainly the tropical forest Amazon (50% of the world's rainforest) to the global GHG panel. To estimate the Amazon emission/absorption flux it is necessary to know the GHG background concentration in Brazilian coast. The objective of this study is to determinate the GHG background that arrives on Brazilian coast, from the Atlantic Ocean.

### 2. Materials and methods

Two sites were studied on the Brazilian coast, Salinópolis, Pará State (SAL: 0° 36' S; 47° 22' W) on the Corvina beach, and at Natal, Rio Grande do Norte State (NAT: 5° 29' S; 35° 15' W) on the Maxaranguape beach. The air samples were collected weekly between 12–13h local time performed in the beach (~10 - 15m above sea level) using glass flasks of 2.5L. The samples were collected in pairs, like a quality assurance sample control. Initially, flasks were flushed with around 50L of air (6L min<sup>-1</sup>) for conditioning the flasks in local conditions. The final sample pressure in flask is around 6-8 psi above ambient pressure. Flasks from both sites were sent to Atmospheric Chemistry Laboratory–IPEN, in São Paulo, Brazil, for analysis the gases: carbon dioxide, methane, nitrous oxide, sulfur hexafluoride and carbon monoxide. The results from both stations were compared with measured mole fractions from two NOAA's global stations: Ascension Island (ASC 7°96'S; 14°40'W) in South Atlantic Ocean (SAO) and Barbados (RPB 13°16'N; 59°43'W), in North Atlantic Ocean (NAO). At NAT we are conducting an inter comparison program with NOAA/ESRL/GMD. Backward trajectories of air masses that arrived in SAL and NAT were simulated by HYSPLIT model (DRAXLER, R.R. and ROLPH, G.D.. HYSPLIT- HYbrid Single-Particle Lagrangian Integrated Trajectory <<http://ready.arl.noaa.gov/hypub-bin/trajtype.pl?runtype=archive>>) for each sample by using 240h retroceding and 10–15 meters of altitude above sea level, to determine the origin and seasonality of air masses for both sites.

### 3. Results and Discussion

Results showed that SAL presents higher seasonality for all GHG when compared to NAT. Simulations of backward trajectories allowed to observe how each study site is influenced by air masses arriving in them. In SAL air masses origin varied during the year, from North Atlantic Ocean (NAO) and South Atlantic Ocean (SAO), while in NAT the air masses were only from the SAO (Figure 1). These patterns were related to the variability in the Intertropical Convergence Zone position throughout the year.

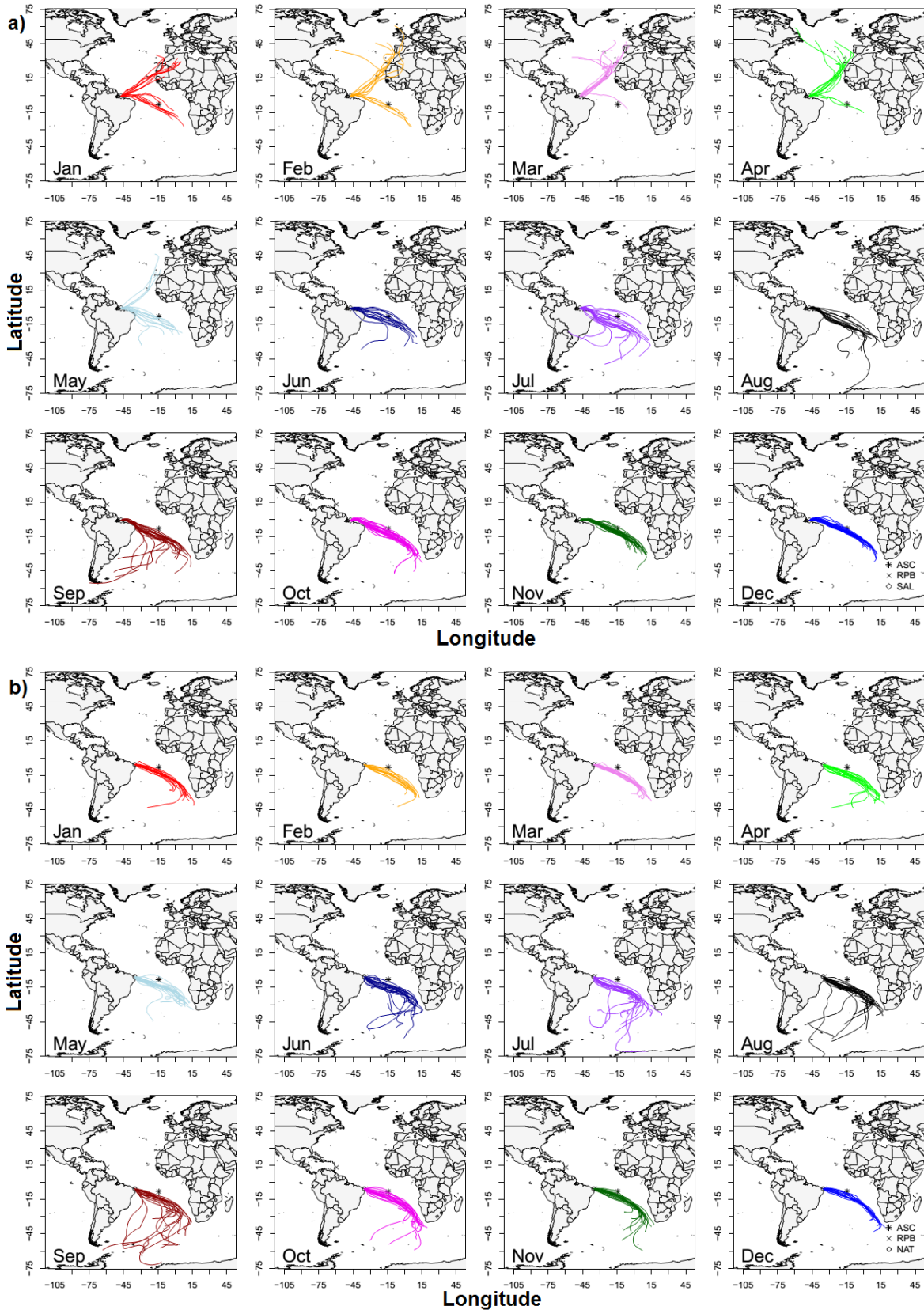
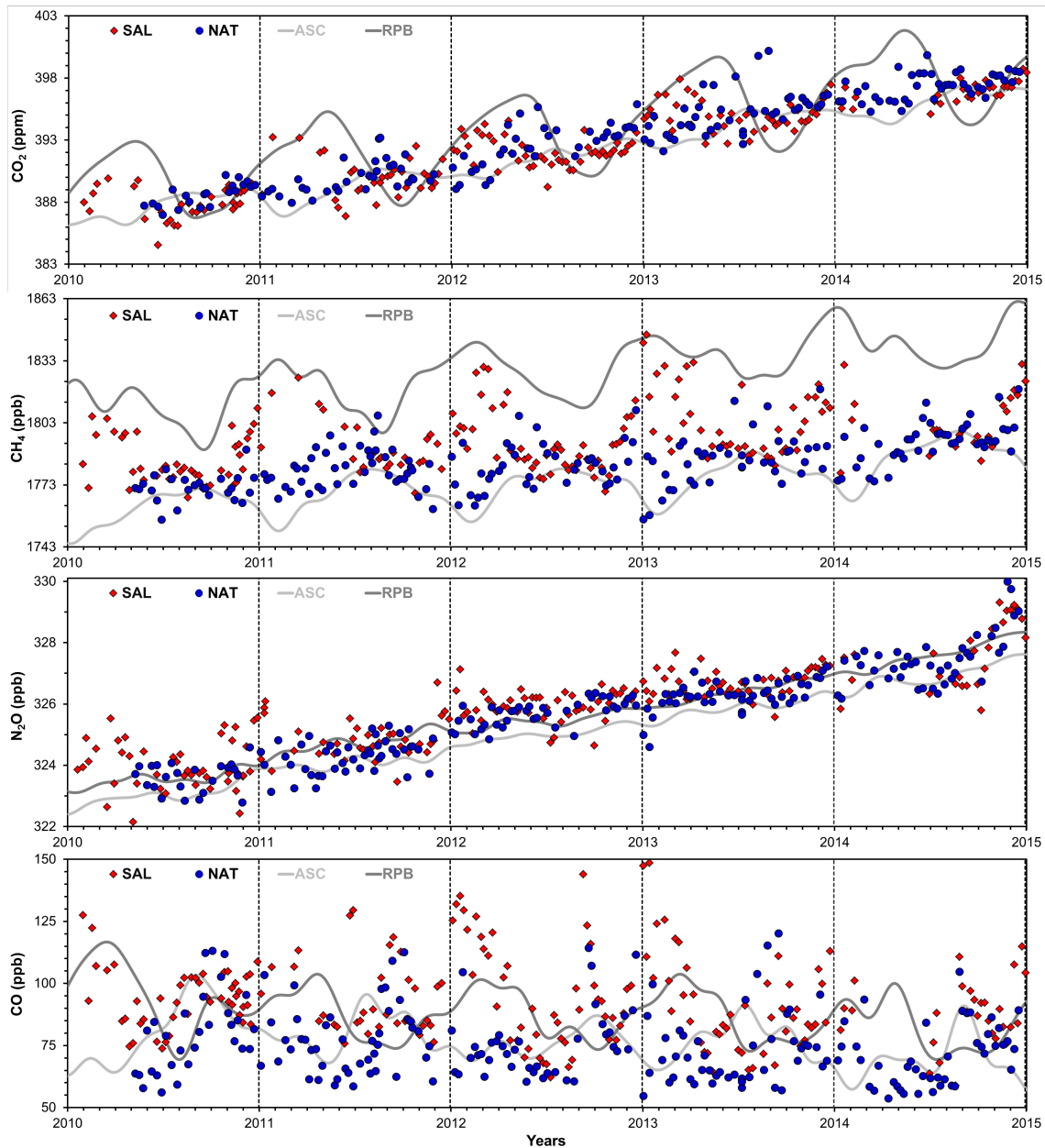


Figure 1. Backward trajectories in (a) SAL and (b) NAT of 2010 to 2014

In the Figure 2, can be observed that usually for all gases the concentrations are between ASC and RPB. The behaviour happens for CO<sub>2</sub> (main anthropogenic GHG), but during the time between May-August we can observe very low concentrations, below ASC, indications a uptake process by the ocean. This same behaviour was observed aircraft vertical profiles conducted near this region.



**Figure 2. Time series in SAL (red) and NAT (blue) for CO<sub>2</sub>, CH<sub>4</sub>, N<sub>2</sub>O and CO. The second most important GHG, CH<sub>4</sub>, presented seasonally throughout the year and show seasonality indicating part time influenced by north hemisphere, when ITCZ is above this region.**

The third most important GHG, N<sub>2</sub>O, presented dispersions, showing more homogeneity in NAT site than SAL site.

The CO that can be used like a burning tracer showed higher concentrations in the period between August to October. During this time, it is happening biomass burning in Africa, and this air mass can arrive there due transport. In NAT, it was observed that the GHG concentrations were similar to the ASC global station, since SAL concentrations are lower than the NAO. The concentrations of measured gases showed seasonality and periods of high CO concentrations, which can be also associated with biomass burning in the Brazilian coast or from another anthropogenic sources.

Overall, both study sites, SAL and NAT showed an increase in their concentrations over the years in the Brazilian coast following the global growth rate (Table 1). In NAT site, it is conducted since 2010 inter comparison between NOAA and IPEN. The sample is conducted by collect first a pair for NOAA then a pair for IPEN. It is not the ideal condition for inter comparison because we have around 20min difference between both pairs. The mean difference during the period 2010–2014 was  $-0.03 \pm 0.03$  ppm for CO<sub>2</sub>,  $0.47 \pm 0.27$  ppb for CH<sub>4</sub>,  $0.37 \pm 0.04$  ppb for N<sub>2</sub>O and  $-1.99 \pm 0.21$  ppb for CO.

**Table 1. SAL and NAT mean concentration and standard deviation**

Gas	Year	SAL	NAT
CO <sub>2</sub> (ppm)	2010	388.01 ± 0.34	388.59 <sup>1</sup> ± 0.30
	2011	390.39 ± 0.38	389.65 ± 0.30
	2012	392.14 ± 0.22	392.59 ± 0.44
	2013	394.94 ± 0.24	395.28 ± 0.39
	2014	396.76 ± 0.22	397.26 ± 0.24
CH <sub>4</sub> (ppb)	2010	1784.92 ± 2.49	1772.25 <sup>1</sup> ± 0.88
	2011	1795.78 ± 4.34	1779.69 ± 1.88
	2012	1794.36 ± 3.47	1782.72 ± 2.01
	2013	1803.38 ± 3.47	1786.34 ± 2.51
	2014	1802.87 ± 3.07	1793.31 ± 2.34
N <sub>2</sub> O (ppb)	2010	323.96 ± 0.12	323.60 <sup>1</sup> ± 0.10
	2011	324.79 ± 0.10	324.28 ± 0.09
	2012	325.97 ± 0.08	325.71 ± 0.10
	2013	326.71 ± 0.07	326.32 ± 0.11
	2014	327.51 ± 0.30	327.47 ± 0.21
CO (ppb)	2010	97.10 ± 3.43	79.85 <sup>1</sup> ± 4.87
	2011	94.15 ± 3.08	76.61 ± 2.56
	2012	96.05 ± 5.33	76.83 ± 3.64
	2013	91.43 ± 4.27	73.50 ± 2.52
	2014	87.47 ± 2.54	71.16 ± 2.71

*Average between: <sup>1</sup>May-Dec.*

#### 4. Conclusions

The variability observed in the air masses influenced the gases concentrations at each site. Was observed an annual seasonality in the GHG concentrations and periods with high CO concentrations associated with biomass burning. Brazilian coast sites (SAL and NAT), showed an increase on their concentrations over the years following the global growth rate. Mean GHG concentrations obtained from both sites increased over the previous year, with exception for CO concentrations, which showed a decrease on the period studied.

#### Acknowledgments

CNPq, NERC, FAPESP, MCTI, NOAA, IPEN.



## GREENHOUSE GAS OBSERVATION NETWORK OF JAPAN METEOROLOGICAL AGENCY IN THE WESTERN NORTH PACIFIC

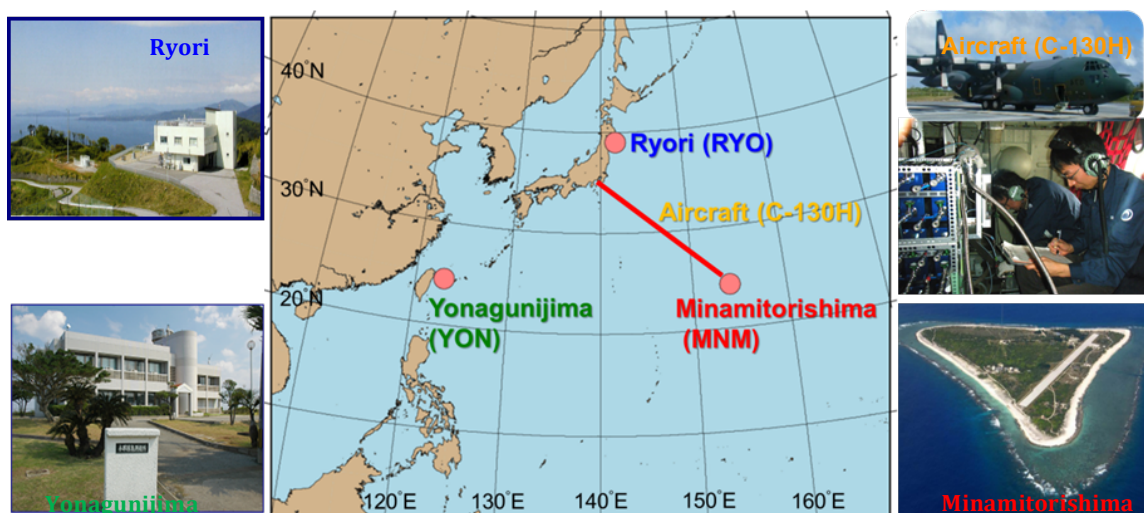
K. Dehara<sup>1</sup>, H. Koide<sup>1</sup>, Y. Esaki<sup>1</sup>, A. Takizawa<sup>1</sup>, S. Takatsuji<sup>1</sup>, T. Okuda<sup>1</sup>, Y. Mori<sup>1</sup>, S. Hosokawa<sup>1</sup>, H. Matsueda<sup>2</sup>, Y. Sawa<sup>2</sup>, K. Tsuboi<sup>2</sup> and Y. Niwa<sup>2</sup>

1. Japan Meteorological Agency (JMA), Tokyo, Japan
2. Meteorological Research Institute (MRI), Ibaraki, Japan

### 1. Observation network of JMA for atmospheric greenhouse gases

The Japan Meteorological Agency (JMA) has operated long-term observations of atmospheric greenhouse gases (GHG) for almost 30 years under the Global Atmosphere Watch (GAW) Programme at 3 ground-based stations. In addition, we have also been conducting an operational aircraft observation since 2011 (Figure 1).

Since 1987, JMA has operated a continuous CO<sub>2</sub> measurement at Ryori station (RYO, GAW regional station) located on a hilly cape at the Pacific coast of the northern part of Japan, and has expanded the observation to measure other trace gases such as CH<sub>4</sub>, CO, N<sub>2</sub>O, halocarbons, and O<sub>3</sub>. Five staff operate the station. In 1993, we established a background air monitoring station at Minamitorishima (MNM, GAW global station), which is an isolated small coral island in the western North Pacific. The background air monitoring is operated by a resident staff, and the staff changes off every three months. In 1997, we began GHG observation at Yonagunijima station (YON, GAW regional station), as the third monitoring station of JMA. Since 2008, the station has been unmanned and remotely operated by remote control system from headquarter of JMA. In 2011, JMA started an operational aircraft observation in the mid-troposphere at an altitude of about 6 km. The aircraft observation is conducted onboard a cargo aircraft C-130H of the Japan Ministry of Defense, which flies from Atsugi air base near Tokyo to Minamitorishima once a month (Tsuboi et al., 2013). Air samples are collected in flasks during a cruising and descending sections to Minamitorishima.



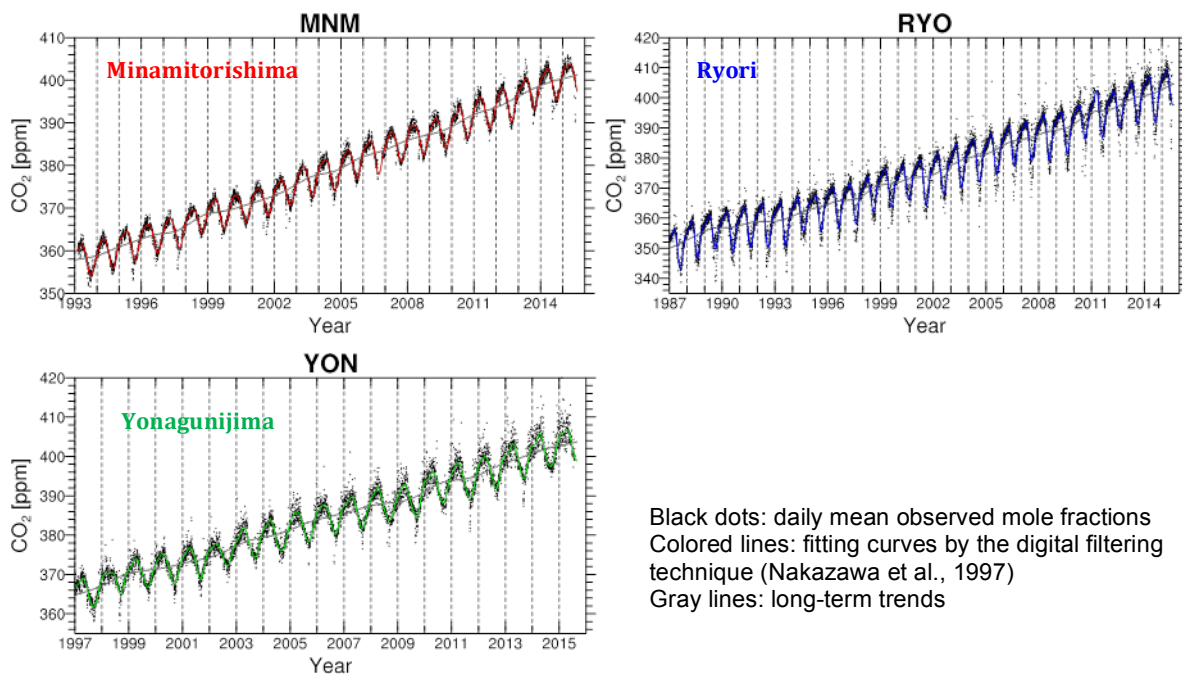
**Figure 1. Observation network of JMA for atmospheric greenhouse gases**

### 2. Observation results and analysis

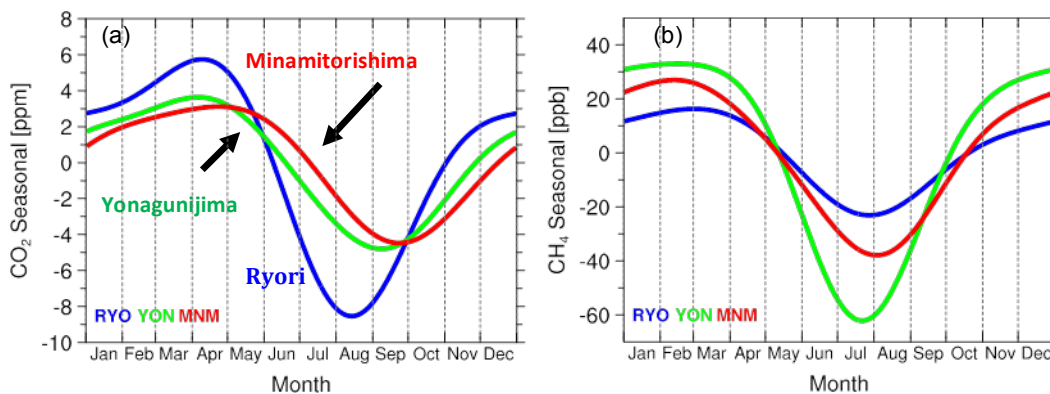
Figure 2 shows time-series of mole fractions of CO<sub>2</sub> at three ground-based stations. We can see clear long-term increasing trends, and seasonal cycles in relation to photosynthesis and

respiration in the biosphere. The averaged seasonal cycles of CO<sub>2</sub> and CH<sub>4</sub> are shown in Figure 3.

These cycles are obtained by the digital filtering with three Fourier harmonics and smoothed by the Butterworth filter (Nakazawa et al., 1997). In the three CO<sub>2</sub> seasonal cycles (Figure 3a), RYO has the largest seasonal amplitude. This is attributable to the fact that RYO is located at the highest latitude and is likely influenced by biosphere activities in the continent. The seasonal maximum and minimum at MNM appear later than at YON despite the almost same latitudes of the two locations. This reflects the distance from the Asian continent, where large CO<sub>2</sub> emissions exist. For CH<sub>4</sub>, seasonal amplitude is the largest at YON (Figure 3b). The variation reflects the influence of emissions from the Asian continent, especially from autumn to spring. Generally, CH<sub>4</sub> is emitted from wetlands, rice paddy fields, ruminant animals, and natural gas production and primarily removed by photochemical reaction with very reactive and unstable hydroxyl (OH) radicals.

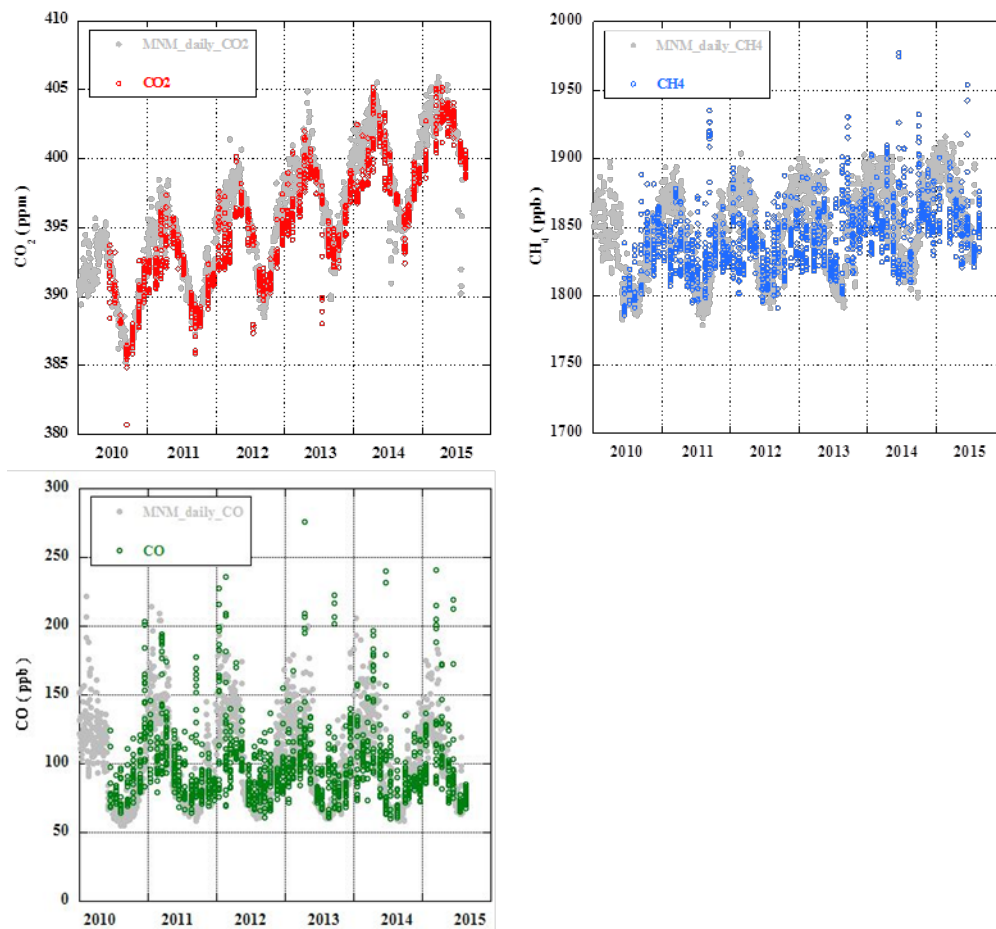


**Figure 2. Observed mole fractions of CO<sub>2</sub> at MNM, RYO and YON**



**Figure 3. Averaged seasonal cycles of CO<sub>2</sub> and CH<sub>4</sub>**

Figure 4 shows time series of mole fractions of CO<sub>2</sub>, CH<sub>4</sub> and CO observed by the aircraft at about 6 km altitude. In the figures, we found clear increasing trends for CO<sub>2</sub> and CH<sub>4</sub>, and these trends are similar to those observed at MNM.

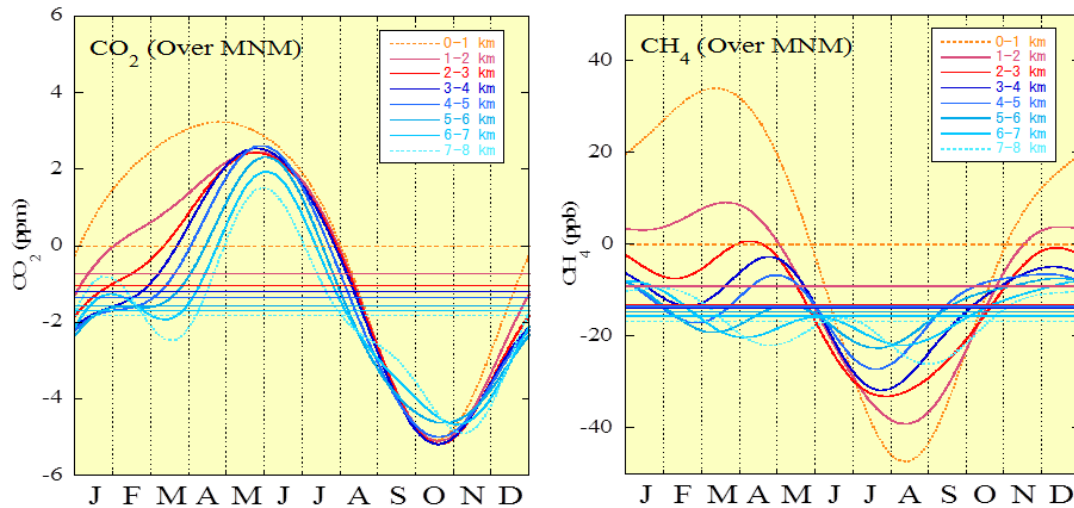


**Figure 4. Mole fractions of CO<sub>2</sub>, CH<sub>4</sub> and CO observed at the flight level (coloured) and at MNM (gray)**

Figure 5 presents averaged seasonal cycles of CO<sub>2</sub> and CH<sub>4</sub> at each altitude over MNM from 0 km to 8 km. We collect 6 flask samples while the aircraft is descending/ascending to/from Minamitorishima. The data shown in Figure 5 are linearly interpolated to each altitude and are averaged for each month, and are finally curve-fitted. The mole fractions were fitted with a smooth curve by the digital filtering technique (Nakazawa et al., 1997).

For the average seasonal cycles, CO<sub>2</sub> mole fractions have a seasonal maximum in May and a minimum in October; this feature is similar to that at MNM. From winter to spring (December–May), the CO<sub>2</sub> mole fraction decreases as the altitude increases. Maximum vertical difference between the near surface and the mid-troposphere is about 5 ppm in spring. The seasonal amplitude in the mid-troposphere is approximately 6–7 ppm, slightly smaller than that at MNM.

On the other hand, the seasonal amplitude of CH<sub>4</sub> is smaller than that at MNM. Furthermore, the seasonal maximum and minimum in the mid-troposphere are not clear.



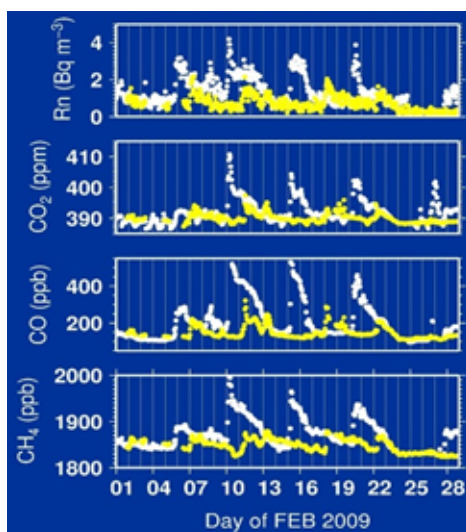
**Figure 5. Average seasonal cycles with relative anomaly to the annual mean mole fraction at 0-1 km**

### 3. Cooperative researches at MNM global station

JMA has conducted a series of cooperative observations such as  $^{222}\text{Rn}$ ,  $\text{CO}_2$  isotope ratio,  $\text{O}_2/\text{N}_2$  ratio, halocarbons at MNM with several research laboratories. These would contribute to understand the carbon cycles in the Western North Pacific region.

Especially  $^{222}\text{Rn}$  has been observed since 2007 at MNM and since 2006 at YON. The high resolution measurement system developed by Meteorological Research Institute (Wada et al., 2010) well captures synoptic scale variations of  $^{222}\text{Rn}$  over the western North Pacific.

Figure 6 shows time series of  $^{222}\text{Rn}$ ,  $\text{CO}_2$ ,  $\text{CO}$  and  $\text{CH}_4$  at YON and MNM in February 2009. The concentration of  $^{222}\text{Rn}$  helps us to infer emissions of GHG in East Asia, because  $^{222}\text{Rn}$  is mainly originated from a soil (like a continent) and is a radioactive noble gas with a half-life of 3.824 days (Wada et al., 2013). In Fig. 6, some peaks of radon are coincident with those of the other trace gases. This suggests that the air masses may be originated from the continent. In addition, we found that peaks at MNM appeared 2-3 days after those at YON. This suggests that the air masses originated from the Asian continent were transported from YON to MNM.



**Figure 6. Time series of hourly mean concentrations of atmospheric  $^{222}\text{Rn}$ ,  $\text{CO}_2$ ,  $\text{CO}$ , and  $\text{CH}_4$  at MNM (yellow) and YON (white) in February 2009**

## References

- T. Nakazawa, M. Ishizawa, K. Higuchi and N. Trivett, 1997: Two curve fitting methods applied to CO<sub>2</sub> flask data, *Environmetrics*, 8, 197-218.
- A. Wada, H. Matsueda, S. Murayama, S. Taguchi, S. Hirao, H. Yamazawa, J. Moriizumi, K. Tsuboi, Y. Niwa and Y. Sawa, 2013: Quantification of emission estimates of CO<sub>2</sub>, CH<sub>4</sub> and CO for East Asia derived from atmospheric radon-222 measurements over the western North Pacific, *Tellus B*, 65, 18037, doi:10.3402/tellusb.v65i0.18037.
- K. Tsuboi, H. Matsueda, Y. Sawa, Y. Niwa, M. Nakamura, D. Kuboike, K. Saito, H. Ohmori, S. Iwatsubo, H. Nishi, Y. Hanamiya, K. Tsuji and Y. Baba, 2013: Evaluation of a new JMA aircraft flask sampling system and laboratory trace gas analysis system, *Atmospheric Measurement Techniques*, 6, 1257-1270, doi:10.5194/amt-6-1257-2013.
- Y. Niwa, K. Tsuboi, H. Matsueda, Y. Sawa, T. Machida, M. Nakamura, T. Kawasato, K. Saito, S. Takatsuji, K. Tsuji, H. Nishi, K. Dehara, Y. Baba, D. Kuboike, S. Iwatsubo, H. Ohmori and Y. Hanamiya, 2014: Seasonal Variations of CO<sub>2</sub>, CH<sub>4</sub>, N<sub>2</sub>O and CO in the Mid-Troposphere over the Western North Pacific Observed Using a C-130H Cargo Aircraft, *Journal of the Meteorological Society of Japan*, 92(1), 55-70, doi:10.2151/jmsj.2014-104.
-

## INTERCOMPARISON EXPERIMENTS OF STANDARD GASES FOR JMA/WCC ACTIVITY

T. Kawasaki<sup>1</sup>, A. Takizawa<sup>1</sup>, M. Takahashi<sup>1</sup>, H. Koide<sup>1</sup>, T. Nakazawa<sup>2</sup>, S. Aoki<sup>2</sup>, S. Morimoto<sup>2</sup>, K. Kato<sup>3</sup>, T. Shimosaka<sup>3</sup>, N. Aoki<sup>3</sup>, T. Watanabe<sup>3</sup>, T. Machida<sup>4</sup>, Y. Tohjima<sup>4</sup>, H. Mukai<sup>4</sup>, K. Katsumata<sup>4</sup>, T. Fujitani<sup>4</sup>, S. Murayama<sup>5</sup>, S. Ishidoya<sup>5</sup>, D. Goto<sup>6</sup>, H. Matsueda<sup>7</sup>, Y. Sawa<sup>7</sup> and K. Tsuboi<sup>7</sup>

1. Japan Meteorological Agency (JMA), Tokyo, Japan
2. Tohoku University (TU), Sendai, Japan
3. National Metrology Institute of Japan (NMIJ/AIST), Tsukuba, Japan
4. National Institute for Environmental Studies (NIES), Tsukuba, Japan
5. National Institute of Advanced Industrial Science and Technology (AIST), Tsukuba, Japan
6. National Institute of Polar Research (NIPR), Tokyo, Japan
7. Meteorological Research Institute (MRI), Tsukuba, Japan

### 1. Introduction

The Japan Meteorological Agency (JMA) operates the World Calibration Centre (WCC) for methane (CH<sub>4</sub>) and the Quality Assurance/Science Activity Centre (QA/SAC) in Asia and the South-West Pacific within the framework of the Global Atmosphere Watch (GAW) Programme of the World Meteorological Organization (WMO). The WMO/GAW program has set a goal for all participating institutions measuring atmospheric CH<sub>4</sub> to report data on the internationally common CH<sub>4</sub> standard scale. Thus, the JMA/WCC has carried out intercomparison experiments of CH<sub>4</sub> reference gas in co-operation with NOAA/ESRL (WMO/CCL,USA), CSIRO (Australia), NIWA (New Zealand), CMA (China), KMA/KRISS (the Republic of Korea), IITM (India), and several Japanese laboratories. The purpose of the JMA/WCC intercomparisons is to identify the differences of their CH<sub>4</sub> standard scales as well as to monitor the long-term stability of standard gases in Asia and the South-West Pacific regions. We report the all results of the past intercomparison experiments of CH<sub>4</sub> since 2002, which are posted on the JMA/WCC website (<http://ds.data.jma.go.jp/gmd/wcc/wcc.html>).

In addition, the JMA and major observation laboratories in Japan have established a domestic alliance with the National Metrology Institute of Japan (NMIJ/AIST) in harmony with the CIPM/WMO MRA in the international sector. Based on this alliance, we started a series of intercomparison experiments named iceGGO (**I**nter-**C**omparison **E**xperiments for **G**reenhouse **G**ases **O**bservations) in 2012. Not only CH<sub>4</sub> but also CO<sub>2</sub> and CO reference gases were circulated to compare their measurements. The iceGGO results could provide more detailed information about the standard gas scales as well as calibration methods used in the Japanese community.

### 2. WCC Activity at JMA (CH<sub>4</sub>)

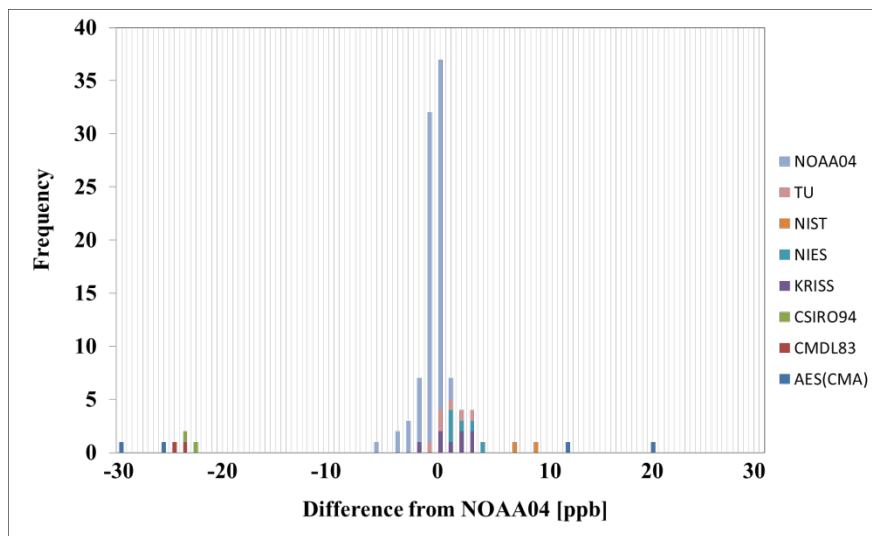
Since Apr. 2001, JMA has carried out reference gases intercomparisons as WCC for CH<sub>4</sub> in Asia and the South-West Pacific (WMO, 2007; Matsueda et al., 2004). In these intercomparisons, two reference cylinders with different CH<sub>4</sub> mole fractions were circulated to compare the JMA measurements with those measured by the 13 laboratories (Table 1).

Figure 1 shows the frequency distribution of the differences in the measured CH<sub>4</sub> mole fractions between the JMA and other laboratories for the 4 round-robin experiments during 2001–2015. The data from these experiments are reported in the JMA/WCC website (<http://ds.data.jma.go.jp/gmd/wcc/wcc.html>). All of the JMA measurements are calculated based on the NOAA-04 gravimetric scale accepted as the World Meteorological Organization (Dlugokencky et al., 2005; Tsuboi et al., 2016). The differences mostly distribute within  $\pm$  5ppb, but some measurements are largely deviated with the range of 10–30 ppb, due mainly to differences of CH<sub>4</sub> calibration scales. These reported values from all the participating

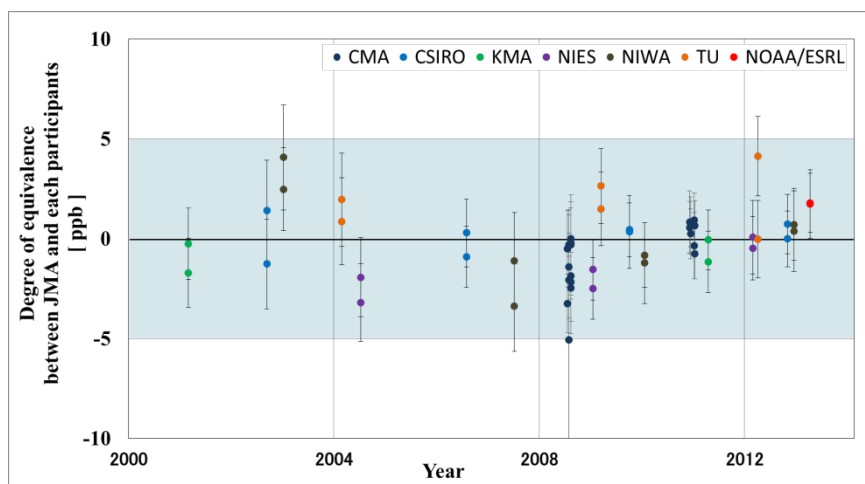
laboratories can be converted to those on the NOAA-04 scale by using the individual scale conversion factors reported by Dlugokencky et al. (2005) as well as by using the results from iceGGO experiments. Figure 2 shows the temporal variations of the differences of the revised measurements between the JMA and the other laboratories after the re-calculations on the same NOAA-04 scale. All of the laboratories show good agreements within the differences of  $\pm 5$ ppb. In addition, no significant trends of the differences with time were observed for all the laboratories. These results strongly indicate that the calibration measurement system for the each laboratory has been maintained well for the past 14 years.

**Table 1. Participants of Methane Reference Gas Intercomparison(2001-2015)**

AIST	National Institute of Advanced Industrial Science and Technology
CMA	China Meteorological Administration
CSIRO	Commonwealth Scientific and Industrial Research Organization
IITM	Indian Institute of Tropical Meteorology
KMA	Korea Meteorological Administration
KRISST	Korea Research Institute of Standards and Science
MRI	Meteorological Research Institute
NIES	National Institute for Environmental Studies
NIPR	National Institute of Polar Research
NIWA	National Institute of Water & Atmospheric Research Ltd.
NOAA/ESRL(CCL)	National Oceanic and Atmospheric Administration/Earth System Research Laboratory
TU	Tohoku University
JMA	Japan Meteorological Agency



**Figure 1. Frequency distributions of differences from NOAA04 (JMA) in the 4 Round-robin experiments. Each legend represents the standard gas scale used in each laboratory.**



**Figure 2. Temporal variations of the revised differences between JMA and each participant during 2001–2015. The scale conversions are described in the text. The error bar represents the expand uncertainty at a 95% level of confidence.**

### 3. Overview of two Inter-comparison experiments conducted in iceGGO

Table 2 shows the overviews of two intercomparison experiments conducted in iceGGO. In iceGGO-3 ( $\text{CO}_2$ ), six laboratories participated, and three standard gases with  $\text{CO}_2$  mole fractions of about 380, 400, and 420 ppm were circulated from Jan. to Sep. in 2014. NMIJ prepared these standard gases as mixtures of purified natural air (without detectable  $\text{CO}_2$ ) and pure  $\text{CO}_2$  by using a gravimetric method. The carbon isotopic compositions ( $\delta^{13}\text{C}$ ) of the pure  $\text{CO}_2$  was about -9 ‰ (VPDB), which is almost same as that for the ambient atmospheric  $\text{CO}_2$ . In contrast to these standards, the carbon isotopic compositions of the standard gases used by the participating laboratories are much lighter (about -30 ‰) than the atmospheric  $\text{CO}_2$  because the pure  $\text{CO}_2$  derived from burned petroleum are used for the individual gravimetric standard gases. It is considered that the NDIR analysers calibrated against these isotopically lighter  $\text{CO}_2$  standard gases result in apparent errors in the measured  $\text{CO}_2$  mole fraction of the air samples (Tohjima et al., 2009). The objective of iceGGO-3 experiment is to quantitatively evaluate such isotope effects for the individual NDIR analysers. Table 3 lists the standard gas scales and instruments used in six laboratories participated in iceGGO-3 ( $\text{CO}_2$ ).

**Table 2. Overview of two experiments conducted as iceGGO**

	<i>iceGGO-3 (<math>\text{CO}_2</math>)</i>	<i>iceGGO-4 (CO)</i>
<i>Period of Intercomparison</i>	Jan. 2014 – Sep. 2014	Aug. 2013 – Aug. 2014
<i>Participants</i>	AIST JMA MRI NIES NMIJ TU	JMA MRI NIES NMIJ TU
<i>Detail of standard gases</i>	3 cylinders (NMIJ): CPD00070, CPD00076, CPD00069, about 380, 400, 420 [ppm] (gravimetric method), $\delta^{13}\text{C} = -8.907, -8.964, -8.908\text{‰}$ , $\delta^{18}\text{O} = -13.099, -13.173, -13.088\text{‰}$ , Purified natural air + pure $\text{CO}_2$	2 cylinders (NMIJ): CPB16249, CPB28680, about 250, 350 [ppb] (gravimetric method) Purified natural air + pure CO



**Table 3. The standard gas scales and instruments used for 6 laboratories in the iceGGO-3**

	<i>AIST</i>	<i>TU</i>	<i>JMA</i>	<i>MRI</i>	<i>NIES</i>	<i>NMIJ</i>
<i>Standard gas scale</i>	AIST	TU X10	WMO X2007	MRI1987	NIES	gravimetric method
<i>Instrument (NDIR)</i>	VIA-500R	VIA-500R VIA-510R LI-6252	VIA-510R	LI-6252	LI-6252	—
<i>Instrument (MS)</i>	MAT-252	MAT-delta S	—	—	—	—

In iceGGO-4 (CO), five laboratories participated, and two standard gases were circulated from Aug. 2013 to Aug. 2014 in the following sequence: NMIJ, NIES, MRI, NIES, TU, JMA and NIES again. These standard gases were SI traceable, and were prepared by a gravimetric method of NMIJ using purified natural air and pure CO, and CO mole fractions were about 250 ppb and about 350 ppb. Table 4 lists the standard gas scales and instruments used in five laboratories participated in iceGGO-4 (CO).

**Table 4. The standard gas scales and instruments used for 5 laboratories in the iceGGO-4**

	<i>MRI</i>	<i>NIES</i>	<i>TU</i>	<i>JMA</i>	<i>NMIJ</i>
<i>Standard gas scale</i>	MRI	NIES	TU2010	WMO X2004	gravimetric method
<i>Instrument</i>	GC-FID	GC-RGD	GC-RGD	GC-RGD	—

#### 4. Result of iceGGO-3 (CO<sub>2</sub>)

Figure 3 shows the difference in the CO<sub>2</sub> mole fractions of the individual participants from those of NIES. Note that the CO<sub>2</sub> mole fractions reported by NIES were corrected for the isotope effect. The differences except NMIJ are scattered within a range of -0.16 to 0.21 ppm. These differences are caused partly by the difference of the CO<sub>2</sub> standard scales used by the participants. The amount of standard scale differences were estimated from the result of iceGGO-2 experiment (Takahashi et al., 2013).

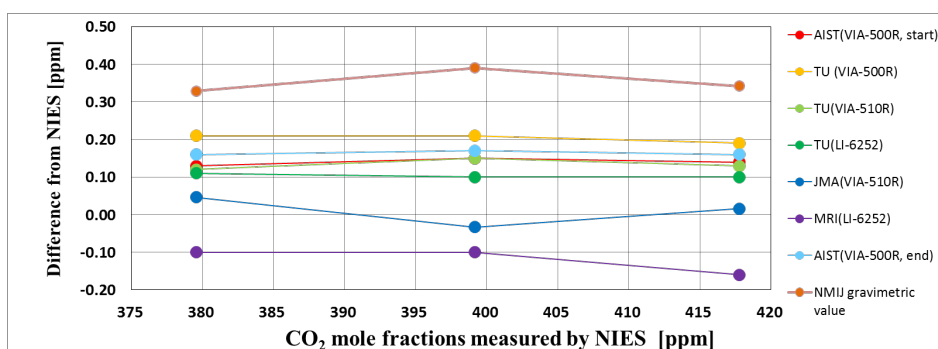
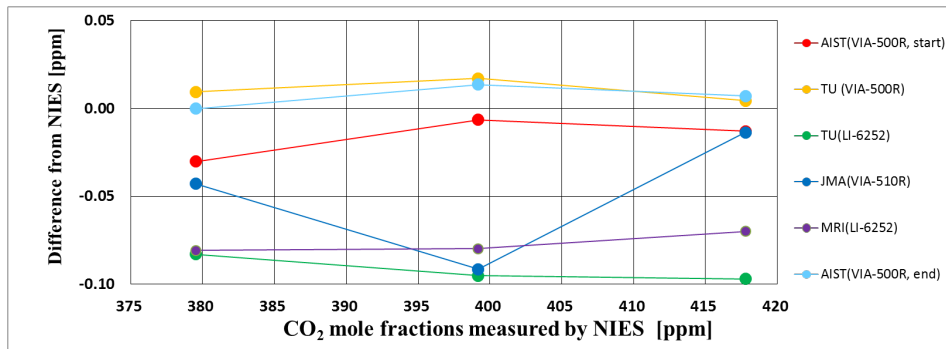
**Figure 3. Difference between NIES and each participant**

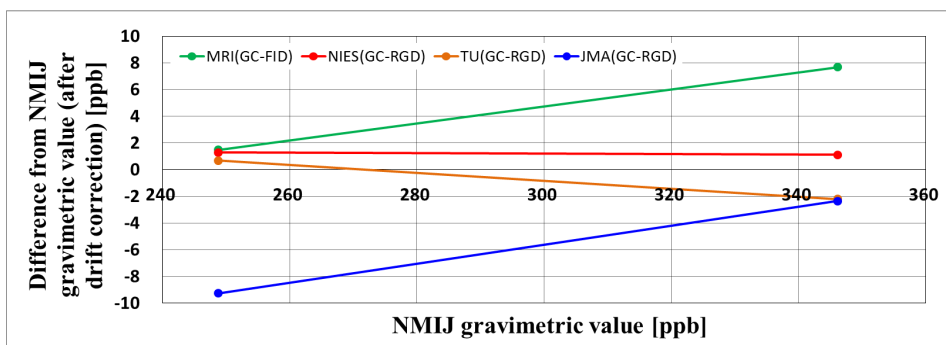
Figure 4 shows the difference between NIES and each participant after adjustment for the differences of the CO<sub>2</sub> standard scales, as stated above. The differences, ranging from -0.10 to 0.05 ppm, are considered to correspond to the errors attributed to the isotope effects for the individual NDIR analysers. It seems that there are systematic differences between the LICOR and VIA-500R, suggesting that the isotope effects of the VIA-500R are relatively smaller while those of the LICOR analysers are larger. The corrections of measured values due to the isotope effects should be determined for individual instrument as pointed out by Tohjima et al. (2009).



**Figure 4. Difference between NIES and each participant after adjustment for the differences of the CO<sub>2</sub> standard scales**

## 5. Result of iceGGO-4 (CO)

Figure 5 shows the difference between NMIJ gravimetric value and each participant after drift correction. The estimated drifts of CO mole fraction were 3.2 ppb yr<sup>-1</sup> - 4.7 ppb yr<sup>-1</sup> during a period of circulation. The differences are scattered within a range of -9 to 8 ppb. The differences among NMIJ, NIES, and TU are within about ±2 ppb. The CO mole fractions measured by JMA are lower than those measured by other laboratories at the lowest sample, while those by MRI are higher than those by other laboratories at the highest sample.



**Figure 5. Difference between NMIJ gravimetric value and each participant**

## 6. Summary

JMA has carried out reference gases intercomparisons as WCC for CH<sub>4</sub> in Asia and the South-West Pacific since Apr. 2001. The results for the past 14 years indicate that the differences of CH<sub>4</sub> measurements from the JMA are within about ± 5 ppb when the reported values are revised on the same NOAA-04 scale accepted as the WMO.

On the other hand, JMA and active observation laboratories in Japan have established a national alliance with NMIJ to compare standard gas scales each other. In this framework, we started intercomparison experiments named iceGGO in 2012. The result of iceGGO-3 experiment shows that we need to consider CO<sub>2</sub> isotope effect in the measurement of natural air because the carbon isotopic compositions of CO<sub>2</sub> in the standard gases are much lighter than that of the atmospheric CO<sub>2</sub>. The result of iceGGO-4 experiment shows that the differences are scattered within a range of -9 to 8 ppb. The alliance will continue the series of the iceGGO to clarify the relation among their scales and to ensure their stability.

### **Acknowledgements**

We gratefully acknowledge all participants for co-operating the JMA/WCC intercomparison experiments.

### **References**

- Dlugokencky et al., 2005: Conversion of NOAA atmospheric dry air CH<sub>4</sub> mole fractions to a gravimetrically prepared standard scale, *Journal of Geophysical Research*, 110, D18306, doi:10.1029/2005JD006035.
- Matsueda et al., 2004: Methane standard gases for atmospheric measurements at the MRI and JMA and intercomparison experiments, *Papers in Meteorology and Geophysics*, Vol. 54 (2004) No. 3+4 March P 91-113.
- Takahashi et al., 2013: *Intercomparison experiments for greenhouse gases observation (iceGGO) in Japan*, GAW Report, No. 213, P 138-143.
- Tohjima et al., 2009: Theoretical and experimental evaluation of the isotope effect of NDIR analyzer on atmospheric CO<sub>2</sub> measurement, *Journal of Geophysical Research*, 114, D13302, doi:10.1029/2009JD011734.
- Tsuboi et al., 2016: Scale and stability of methane standard gas in JMA and comparison with MRI standard gas, *Papers in Meteorology and Geophysics* (submitted to).
- WMO, 2007: *WMO Global Atmosphere Watch (GAW) Strategic Plan: 2008-2015*, GAW Report, No. 172, P 18, World Meteorological Organization, Geneva, Switzerland.
-

## EIGHT YEARS OF IN SITU MEASUREMENTS OF CH<sub>4</sub>, N<sub>2</sub>O AND CO MADE WITH A PROTOTYPE FOURIER TRANSFORM TRACE GAS ANALYSER AT LAUDER, NEW ZEALAND

Dan Smale<sup>1</sup>, Vanessa Sherlock<sup>1</sup>, David Griffith<sup>2</sup>, Gordon Brailsford<sup>1</sup>, Rowena Moss<sup>1</sup>, Mike Kotkamp<sup>1</sup>, Sylvia Nichol<sup>1</sup>

1. National Institute of Water and Atmospheric Research, NZ
2. University of Wollongong, Australia
3. National Center for Atmospheric Research, USA

### 1. Introduction

A prototype in situ Fourier transform infra-red spectrometer trace gas analyser (IFTS, Griffith, 2012) has been operating at Lauder, New Zealand (45S, 170E, 370m) since August 2006. Prior GGMT presentations have focussed on characterizing the performance of the IFTS CO<sub>2</sub> measurements. Here we investigate the performance of the Lauder (LAU) IFTS at measuring CH<sub>4</sub>, CO and N<sub>2</sub>O then comparing these measurements to similar measurements made at Baring Head, New Zealand (41S, 175E, 87m).

#### 1.2 How the IFTS works

Continuous measurements of CO<sub>2</sub>, CH<sub>4</sub>, CO and N<sub>2</sub>O are made from air drawn from a 10 metre mast. The air sample is dried to <20 ppm<sup>1</sup> H<sub>2</sub>O with a Nafion drier and Mg(ClO<sub>4</sub>)<sub>2</sub> trap. The IFTS consists of a Bruker Optics IRCube interferometer coupled to a multi-pass sample gas cell (optical path 24 meters, volume 3.5L). The IFTS is thermostatically controlled, and since 2013 the sample cell pressure is actively stabilised. The mid-infrared spectra (1750-6750cm<sup>-1</sup>) are recorded and averaged over ten minute intervals as air flows continuously through the sample cell. The retrieved gas concentrations (via MALT spectral fitting analysis, Griffith, 1996) are converted to dry mole fraction by dividing by the sample cell air concentration and correcting for H<sub>2</sub>O in the sample.

### 2. IFTS precision and accuracy

Precision: The repeatability of the IFTS measurements is calculated from Allan variance analysis (Allan, 1966) for the measurement averaging time (10 minutes), see Table 1.

**Table 1. IFTS precision 1-σ standard deviation (SD) for a 10- minute spectra average, empirically derived linear RPS and the current trace gas calibration scale for each species**

Species	Precision (10 minute mean) [ppb]	RPS [ppb hPa <sup>-1</sup> ]	Current working tank scale
CH <sub>4</sub>	0.2	0.034	WMOx2004A
CO	0.3	0.001	WMOx2014
N <sub>2</sub> O	0.05	0.008	NOAA2006A

Corrections: Prior to an instrument upgrade in mid-2013 the IFTS had a large operational cell pressure range (815mB–950mB), with differences between sample and calibration cell

<sup>1</sup> mole fraction abbreviations: ppm => μmol mol<sup>-1</sup>, ppb => nmol mol<sup>-1</sup>

pressure of up to 50mB. Under such conditions it is necessary to apply a residual pressure sensitivity (RPS) correction (Hammer, 2013) to the retrieved dry mole fraction. After the upgrade cell pressure is kept at 1100hPa +/- 0.5hPa, dramatically reducing RPS correction.

Accuracy: RPS corrected CH<sub>4</sub>, CO and N<sub>2</sub>O dry mixing ratios of a routinely measured single working tank (WT) are scaled by the assigned WT dry mole fraction to give a scale factor (SF). The SF is applied to sample measurements to place them on the WMO/NOAA trace gas calibration scales. WT's are prepared by NIWA-Gaslab with a lineage to WMO-CCL scales.

### 3. A customized IFTS calibration suite

A dedicated IFTS scale transfer standard gas tank suite (referred to as the *Aniwaniwa* suite) was designed by NIWA and prepared at NOAA ESRL-GMD. It has a customized trace gas composition matrix consisting of prescribed CO<sub>2</sub>, CH<sub>4</sub>, N<sub>2</sub>O and CO mole fractions spanning the typical trace gas concentrations seen at LAU. The composition matrix (see Table 2) is configured to minimize gas measurement cross sensitivity/covariance in the MALT retrieval algorithm. The MALT retrieval code performs spectra fitting across four independent micro-window bands. Preference for species concentration orthogonality is given to species retrieved in the same micro-window band (for example CO and N<sub>2</sub>O).

**Table 2. Species concentrations of the four tank calibration suite. The three coloured bands (orange, green, and aqua) in the table cells correspond to the three independent MALT retrieval micro-window bands used in the retrieval of the four species. Table cell brightness is related to relative concentration, lighter the colour the lower the relative concentration.**

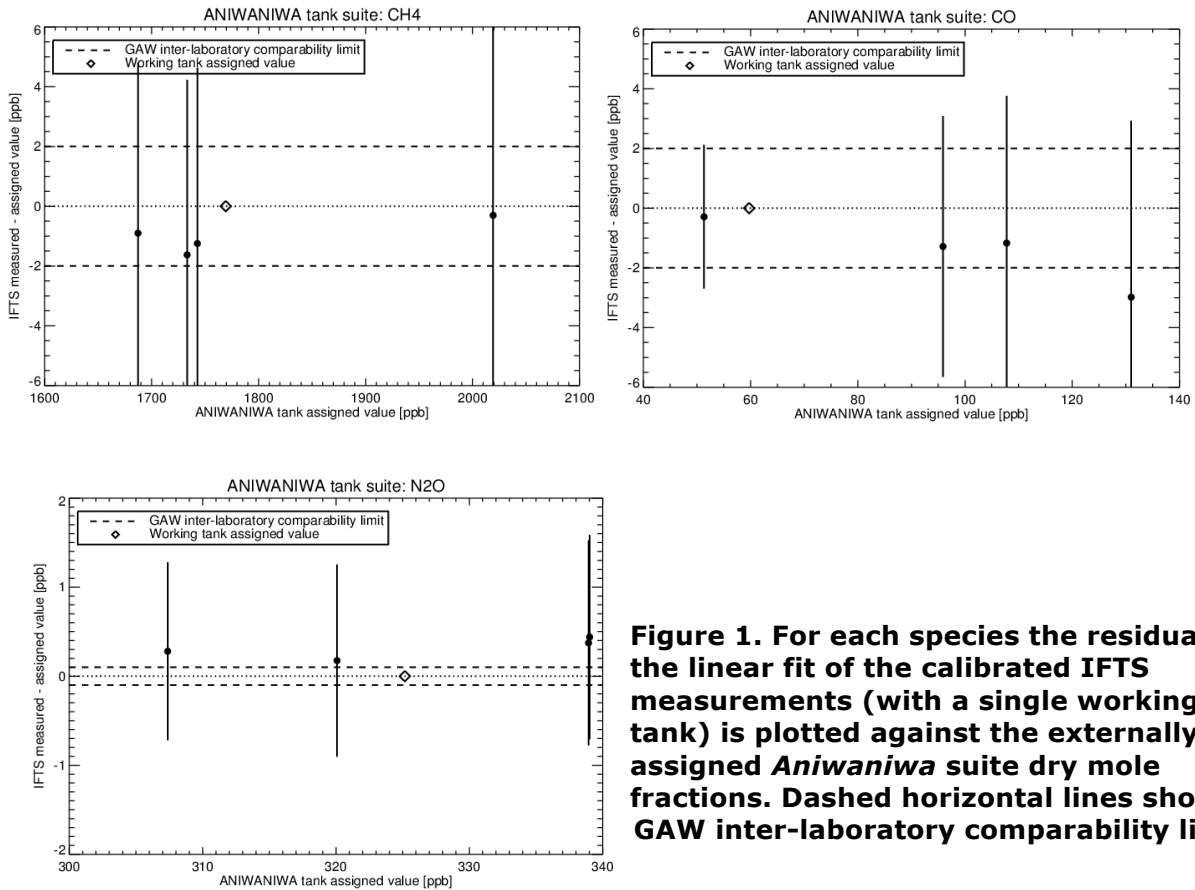
Tank ID	CO <sub>2</sub> [ppm] WMOx2007	CH <sub>4</sub> [ppb] WMOx2004A	CO [ppb] WMOx2014	N <sub>2</sub> O [ppb] NOAA2006A
CB09978	412.70	1733.24	95.90	339.02
CB10005	398.51	1687.32	131.01	320.08
CB10248	457.68	1742.82	51.32	307.38
CB10202	380.42	2019.30	107.77	338.94

### 4. Introduced bias when using a single working tank

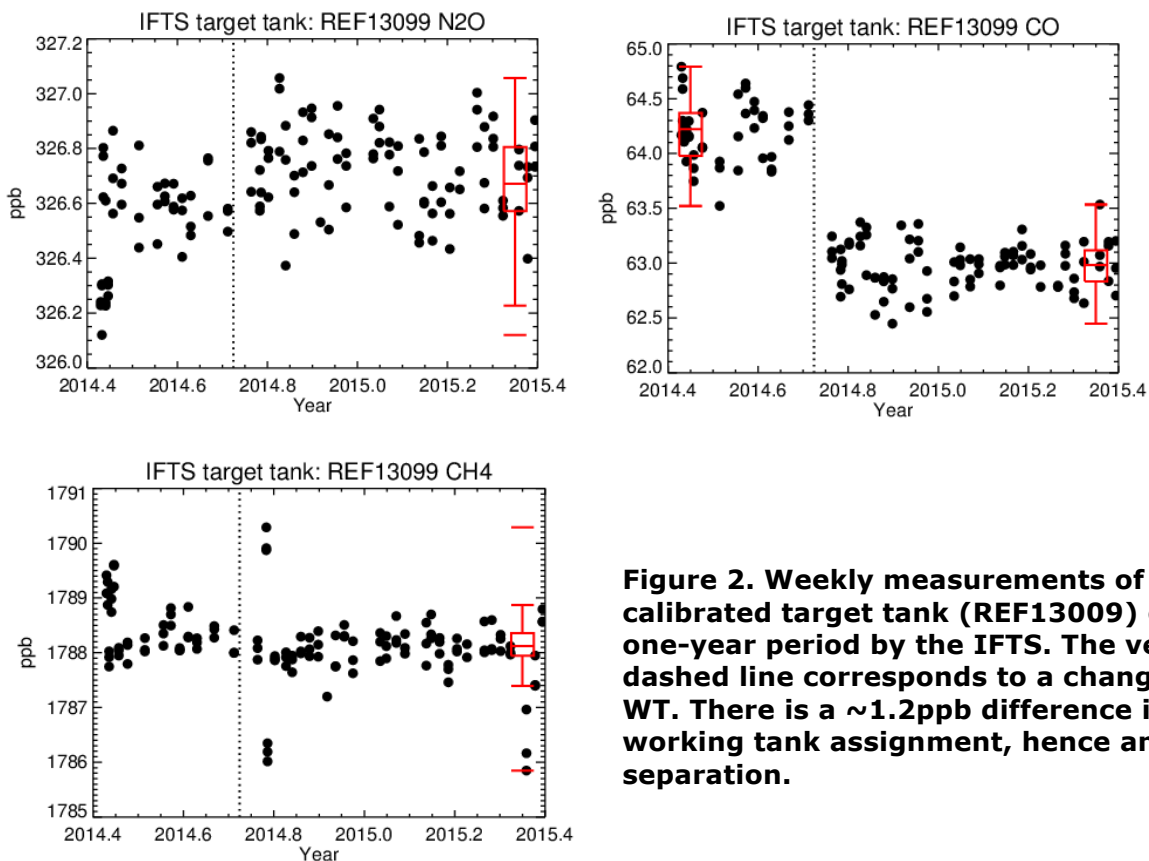
*Aniwaniwa* suite measurements confirm that the IFTS response function is linear with a non-zero y-intercept (Griffith, 2012 & Hammer, 2013). Linear calibration with a single WT (operational configuration to date) cannot account for a non-zero y-intercept term. The resultant calibration bias by assuming a zero offset has a dependence on the difference between the WT assignment and sample abundance. Figure 1 shows a minimal concentration dependent bias in all three species when the single WT is of similar composition to the expected sample measurement abundances.

### 5. Monitoring long term instrument stability

Since 2012, a target tank (TT) has been routinely measured by the IFTS system to monitor short term and long term instrument stability (reproducibility), additionally it provides a check on WT drift until a multi working tank suite is employed. It is advantageous to interleave TT and WT cylinder changes to minimize TT and WT correlations. Figure 2 displays measurements over the lifetime of one TT. Temporal drift in all three species concentrations is minimal. CH<sub>4</sub>, CO and N<sub>2</sub>O TT 1-σ SD are 0.65, 0.24, and 0.19 (ppb) respectively.



**Figure 1.** For each species the residual to the linear fit of the calibrated IFTS measurements (with a single working tank) is plotted against the externally assigned *Aniwaniwa* suite dry mole fractions. Dashed horizontal lines show the GAW inter-laboratory comparability limits.



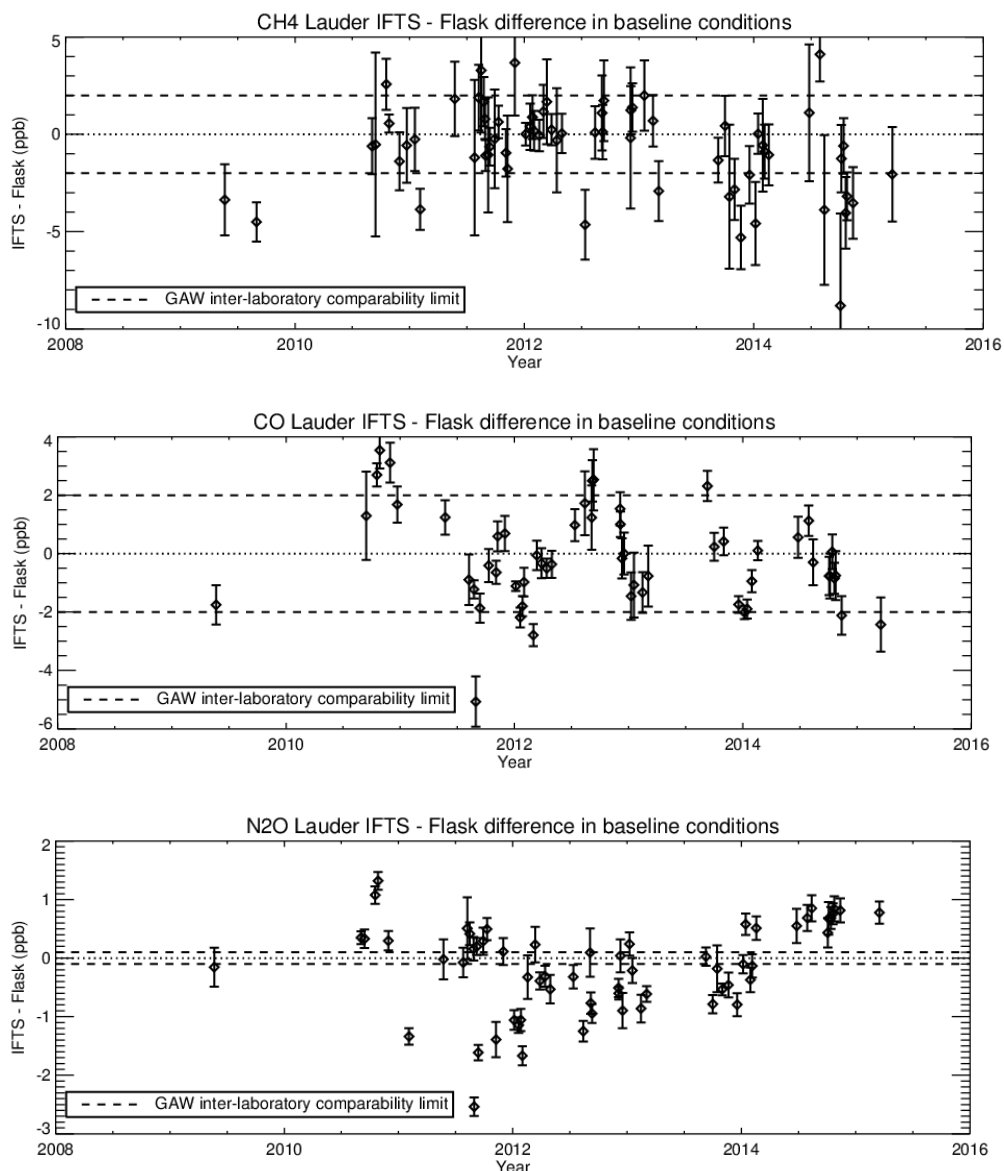
**Figure 2.** Weekly measurements of a calibrated target tank (REF13009) over a one-year period by the IFTS. The vertical dashed line corresponds to a change in the WT. There is a ~1.2ppb difference in the CO working tank assignment, hence analysis separation.

## 6. Lauder IFTS GC-flask comparison

IFTS measurements are compared to trace gas concentrations derived from gas chromatography (GC) of flask air samples acquired routinely in baseline conditions (see Section 7.1 for definition) at LAU since May 2009 (Figure 3). Bias and 1- $\sigma$  SD for each species are displayed in Table 3. CH<sub>4</sub> and CO bias and SD meet GAW compatibility goals (dotted lines) whilst N<sub>2</sub>O bias is more serendipitous, given the comparison SD.

**Table 3. Bias and 1- $\sigma$  SD (IFTS-flask) for each species over the comparison period: 2009-2015**

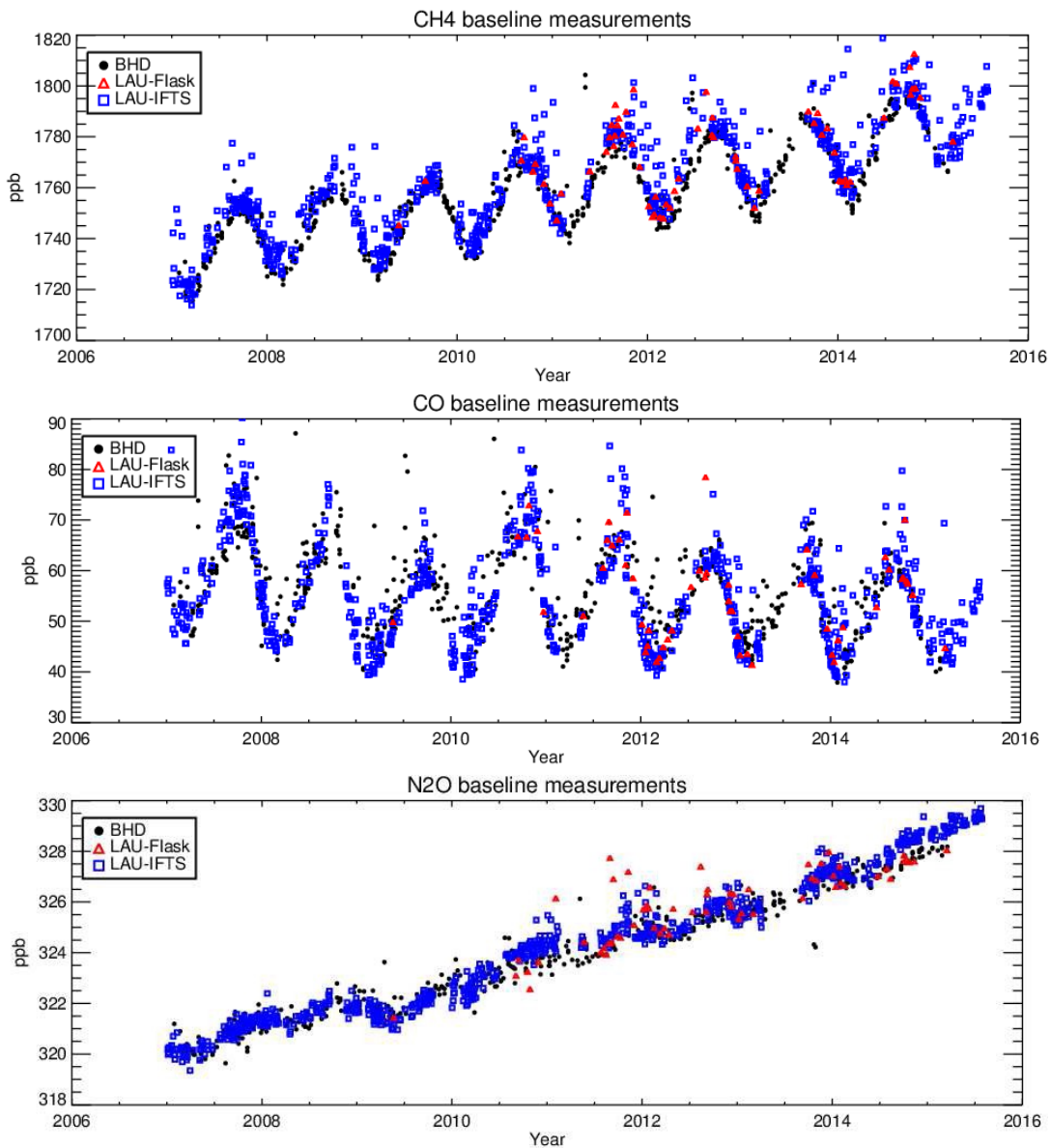
Species	Bias ( $\mu$ ) ppb	( $\sigma_x$ ) ppb
CH <sub>4</sub>	-0.66	2.32
CO	-0.19	1.65
N <sub>2</sub> O	-0.15	0.77



**Figure 3. IFTS-flask bias and 1- sigma SD are shown for each species**

## 7. Lauder - Baring Head comparison

Figure 4 shows a comparison of baseline concentrations at LAU (rural inland site) against Baring Head (BHD, coastal southern ocean site) GC-flask baseline measurements (Brailsford, 2012). Back trajectory modelling shows that in baseline conditions both sites have a considerable origin of air component from the Tasman Sea and/or Southern ocean, but in addition LAU also sees air masses that have had last surface contact from the west of the South Island of New Zealand, an abundant temperate rain forest area. In contrast to LAU-BHD CO<sub>2</sub> baseline measurement comparisons (Steinkamp, GGMT2015 poster) we do not see any seasonal drawdown or elevated levels at LAU for CH<sub>4</sub>, CO and N<sub>2</sub>O. Both sites show remarkably similar trends and season cycles for all three trace gases alluding to a lack of any large scale local terrestrial biogenic -or anthropogenic- sinks/sources. Both sites capture a curious decrease in N<sub>2</sub>O during 2009.



**Figure 4. LAU IFTS (blue square) and GC-flask (red triangle) baseline measurements overlaying BHD (black circle) baseline GC-flask measurements for the three species. Linear trend for each species: CH<sub>4</sub>, ~6ppb/year, CO: ~-1ppb/year, N<sub>2</sub>O: 1ppb/year.**



## 7.1 **Baseline definition**

We define baseline to represent a well-mixed planetary boundary layer with minimum trace gas variability. The Baseline conditions at LAU and BHD are given below:

- LAU baseline: Measurements taken between 15:00-16:00 NZST when the mean wind speed > 5 m/s.
- BHD baseline: When CO<sub>2</sub> 1- $\sigma$  SD (measurements via a continuous analyser) over a 6 hour interval is < 0.2ppm.

## 8. **Summary**

- Operation of the IFTS over the past eight years has shown the instrument repeatability and reproducibility to be stable over the long term.
- Concentration dependent bias arising from using a single working tank is minimized when the composition of the working tank is similar to that of the expected atmospheric baseline abundances.
- Comparison of the IFTS and GC-flask measurements show that the bias in CH<sub>4</sub> of -0.7ppb +/- 2.3 (IFTS - flask) and CO (-0.2ppb +/- 1.7) are within the recommended GAW Inter-Laboratory comparability limits of 2ppb respectively. Whilst the bias in N<sub>2</sub>O (of -0.15ppb) is bordering on the accepted limit of 0.1ppb, the spread of 0.8ppb is outside the current recommended GAW limits.
- The IFTS time series captures the seasonal variations in CH<sub>4</sub> and CO, the secular rise in CH<sub>4</sub> since 2006, an increase in the upward trend in N<sub>2</sub>O since mid-2009 and the downward trend in CO.

### 8.1 **Outlook**

- Lauder IFTS and GC-flask CH<sub>4</sub> measurements have been submitted to the WDCGG. We are now approaching the point where IFTS-CO can also be submitted.
- A multi-tank working tank suite is to be employed to allow characterisation of the non-zero linear offset. This will reduce the concentration dependent bias inherent in the current calibration scheme.

## **Acknowledgements**

We would like to thank Nicholas Deutscher & Stephen Parkes. Martin Riegenbach, Sam Hammer and Graeme Kettlewell also provided invaluable technical advice and support for the prototype FTIR analyser. This research is supported by NIWA core funding through funding from New Zealand's Ministry for Business, Innovation and Employment.

## **References**

- Allan, D., 1966: *Statistics of Atomic Frequency Standards*, Proceedings of IEEE, Vol. 54, No. 2, February 1966.
- Brailsford, G.W., B.B. Stephens, A. J. Gomez, K. Riedel, S. Mikaloff-Fletcher, S.E. Nichol and M.R. Manning, 2012: Long-term continuous atmospheric CO<sub>2</sub> measurements at Baring Head, New Zealand, *Atmospheric Measurement Techniques*, 5, 3109-3117.
- Griffith, D.W.T., 1996: Synthetic calibration and quantitative analysis of gas phase infrared spectra, *Applied Spectroscopy*, 50(1), 59-70.

Griffith, D.W.T., N. Deutscher, C. Caldw, G. Kettlewell, M. Rikkenbach, S. Hammer, A Fourier transform infrared trace gas analyser for atmospheric applications, *Atmospheric Measurement Techniques*, 5, 2481–2498, 2012.

Hammer, S., D.W.T. Griffith, G. Konrad, S. Vardag, C. Caldw and I. Levin, Assessment of a multi-species in-situ FTIR for precise atmospheric greenhouse gas observations, *Atmospheric Measurement Techniques*, 6, 1153–1170, 2013.

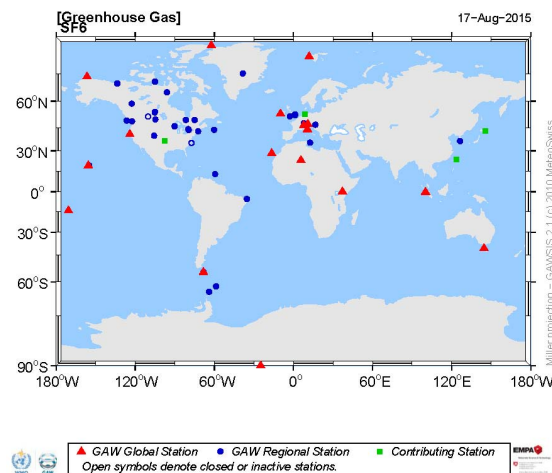
---

## RECENT ACTIVITIES OF WMO GAW WORLD CALIBRATION CENTRE FOR SF<sub>6</sub>

Haeyoung Lee<sup>1</sup>, Chulkyu Lee<sup>1</sup>, Se-Won Kim<sup>1</sup>, Hee-Jung Yoo<sup>2</sup>, Hong-Woo Choi<sup>2</sup>, Sang-Ok Han<sup>2</sup>, Sang-Boom Ryoo<sup>2</sup>, Jeong-Sik Lim<sup>3</sup> and Jeong-Soon Lee<sup>3</sup>

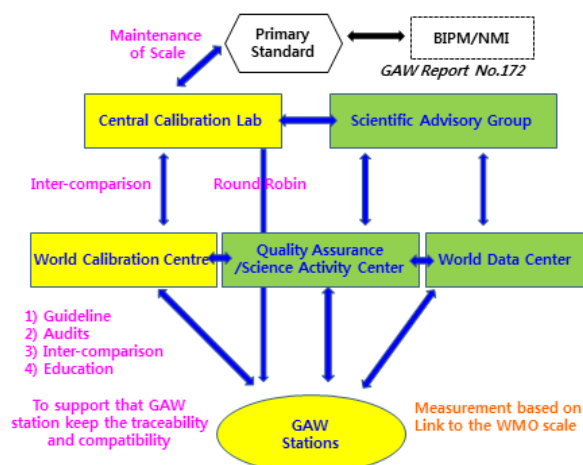
1. Climate Science Bureau, Korea Meteorological Administration, Seoul, Korea
2. National Institute of Meteorological Science, Korea Meteorological Administration, Jeju, Korea
3. Korea Research Institute of Standard and Science, Deajeon, Korea

Sulfur hexafluoride (SF<sub>6</sub>) is known as one of the most potent greenhouse gases. Once emitted into the atmosphere, SF<sub>6</sub> is removed slowly while it is rapidly accumulating in atmosphere due to its atmospheric lifetime of about 3200 years [1]. According to recent WMO Greenhouse Gas Bulletin (2015), atmospheric SF<sub>6</sub> concentration is about 8 ppt, twice of the level observed in the mid-1990s increasing nearly linearly [2]. It is not serious level in present but its Global Warming Potential is 22,800 times higher than carbon dioxide (CO<sub>2</sub>) that these features have brought SF<sub>6</sub> into the climate change discussion aimed at reduction of emissions. Under the GAW umbrella, 55 stations are monitoring atmospheric SF<sub>6</sub> with 17 global stations, 33 regional stations and 5 contributing stations to look at its global and regional state in the atmosphere (Figure 1). However, to understand its role, high quality, long-term, and globally harmonized observations are strongly required in a traceability chain and compatibility goal from Central Calibration Laboratory (CCL) in GAW.



**Figure 1. Distribution of GAW stations where monitor atmospheric SF<sub>6</sub> from GAWSIS ([www.gaw.empa.ch/gawsis](http://www.gaw.empa.ch/gawsis))**

To link between GAW stations and CCL, World Calibration Centre (WCC) acts as a bridge to support all stations with the following activities: a) assist WMO members operating GAW station to link their SF<sub>6</sub> observations to the WMO reference scale through comparisons with standards calibrated against CCL; b) assist Scientific Advisory Group (SAG) on Greenhouse Gases in the development of the quality control procedures required to support the quality assurance of SF<sub>6</sub> measurement and ensure the traceability to WMO scale; c) maintain laboratory and transfer SF<sub>6</sub> gas standards that are traceable to WMO scale; d) perform regular calibrations and inter-comparison campaign involving all GAW stations and labs e) assist in provision of training and long-term technical help for the stations f) make public its involvement in the WMO GAW Programme.



**Figure 2. Conceptual framework of GAW quality assurance system**

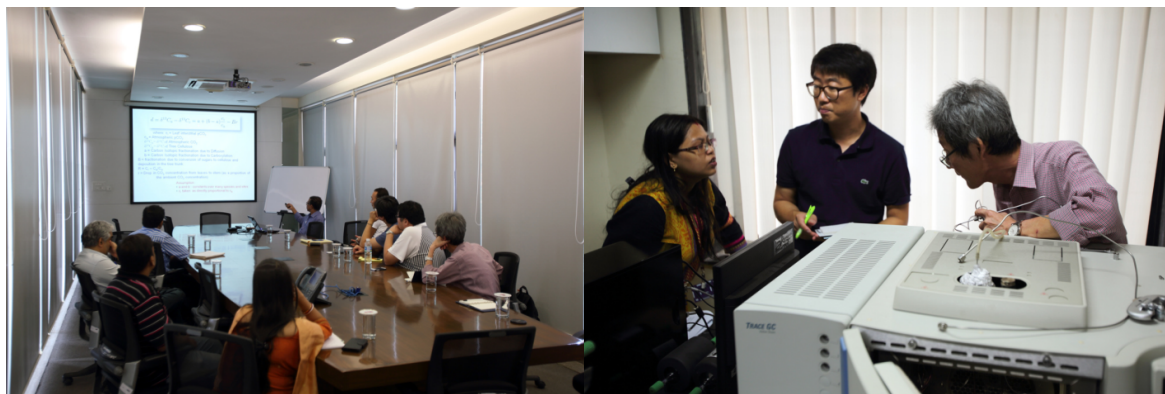
In this newsletter, recent performances which are implemented by WCC-SF<sub>6</sub> related to the activities.

### Develop technical note for SF<sub>6</sub> analysis methods using GC-μECD

Many laboratories and stations have a difficulty to measure SF<sub>6</sub> using GC-μECD (Gas Chromatography - micro Electron Capture Detector) that recently WCC-SF<sub>6</sub> published a technical report for the analysis methods of atmospheric SF<sub>6</sub> as a GAW report No. 222. It described three methodologies with conventional GC- μECD, coupled with a pre-concentrator and fore-cutting/back-flush method. For conventional GC- μECD method, analytical conditions such as oven, sample loop, detector, column and etc. are described variously and applicable examples are given to enhance the peak area and to separate from other peaks such as N<sub>2</sub>O and O<sub>2</sub>. Secondly for pre-concentrator with GC- μECD was suggested one of the analytical methods. It is very useful to enhance the sensitivity of response with a process in which the ratio of the quantity of a desired trace element to that of the original matrix is increased. In this technical note, all concentration process including valve positions and cooling/heating steps are described. Practical analytic conditions were also showed with detailed information. Lastly Fore-cutting/back-flush method is known as a candidate method to avoid the interference of O<sub>2</sub> peak in the analysis of atmospheric SF<sub>6</sub> in short retention time. We described how to set up the system with 10- and 4-port valves according to column setting. Each column setting showed the appropriate examples with type of column. This technical note showed a self-diagnosis flow chart to secure measurement conditions, restrictor information, flasks sampling materials and sample tubes. The report is available on the WMO GAW webpage ([www.wmo.int/pages/prog/arep/gaw/gaw-report.html](http://www.wmo.int/pages/prog/arep/gaw/gaw-report.html)) [3].

### Technical supports to monitoring station

To close the gaps between in situ stations and to get more information of atmospheric SF<sub>6</sub> in Asia, WCC-SF<sub>6</sub> visited IITM (Indian Institute of Tropical Meteorology) and supported their set-up of the system to monitor SF<sub>6</sub> and N<sub>2</sub>O simultaneously with help of KRISS (Korea Research Institute of Standard and Science) during 19 to 23, September (Figure 3). We changed some conditions such as carrier gas from N<sub>2</sub> to P-5 (Ar 95% + CH<sub>4</sub> 5%), column in oven from Hysep to Porapak-Q, and sample loop for an injection from 2 cc to 5 cc. SF<sub>6</sub> and N<sub>2</sub>O were started monitoring together and to separate two peaks, some condition such as flow rate and oven temperature were adjusted. These activities were based on the published technical report by WCC-SF<sub>6</sub>, WMO GAW report No. 222. Through these support, WCC-SF<sub>6</sub> contribute to enhancing monitoring activities and gathering high quality data.



**Figure 3. WCC-SF<sub>6</sub> activities in IITM, India from 19 to 23 September, 2015**

### **WCC-SF<sub>6</sub> training and education course**

Since 2014, WCC-SF<sub>6</sub> has held the training and education course on greenhouse gases. It is to assist GAW station members in a help for their monitoring activities. This year 2<sup>nd</sup> WCC-SF<sub>6</sub> training and education course was implemented during 3 days from 19 to 21 October in 2015, Anmyeondo station, Korea (Figure 4). Seven participants from India, Malaysia, Viet Nam, Indonesia, Jordan, Tajikistan and Costa Rica attended the course in 2015. In the course, a theory of cavity ring down spectroscopy and gas chromatography, practical laboratory exercises for flask sampling and its actual analysis performance were implemented. After the course, most participants wanted to expand the period of the course and have more practical activities. Therefore the course is going to not only focus on more classes which are applicable back to labs and in situ stations but also extend the period to one week from next year.



**Figure 4. The 2<sup>nd</sup> WCC-SF<sub>6</sub> training and education course at Anmyeondo station from 19 to 21 October, 2015**

### **Inter-comparison experiment**

Recently Central Calibration Laboratory in National Oceanic and Atmospheric Administration implemented the 6<sup>th</sup> WMO Round Robin Comparison Experiment to maintain the link to the WMO scales using normal operating procedures. For SF<sub>6</sub>, 18 labs had participated and among them only 4 labs were within WMO compatibility goal,  $\pm 0.02$  ppb. WCC-SF<sub>6</sub> is going to hold the inter-comparison experiment again in cooperation with KRISS and CCL in 2016. For this plan, we have developed the procedure of the inter-comparison experiment and technical method for tertiary/travelling SF<sub>6</sub> standard gases.

**Plans for 2016**

Next year, WCC-SF<sub>6</sub> is going to implement these activities: a) to publish a technical note of calibration method for SF<sub>6</sub>, b) to have an audit and support the monitoring activity of SF<sub>6</sub> at Cape Point station in early of 2016, c) to hold 3<sup>rd</sup> WCC-SF<sub>6</sub> training and education course with extended period and expanded course, and d) to perform the 1<sup>st</sup> inter-comparison experiment from January 2016. All activities which were conducted from 2014 to 2015 will have submitted to WMO GAW this year.

**References**

- [1] Ravishankara AR et al., 1993: Atmospheric lifetimes of long lived halogenated species, *Science*, 259, 194-199.
  - [2] WMO, 2015: WMO Greenhouse Gas Bulletin
  - [3] World Calibration Centre for SF<sub>6</sub>, 2015: *Analytical methods for atmospheric SF6 using gas chromatography with micro electron capture detector*, GAW Report No. 222. 47 pp.
-

## QUANTIFYING THE NET EXCHANGE ECOSYSTEM FOR DIFFERENT LAND USE IN PAMPA BIOME IN SOUTHERN BRAZIL

D. R. Roberti<sup>(1)</sup>, M. B. Diaz<sup>(1)</sup>, O. L. L. Moraes<sup>(1)</sup>, O. Acevedo<sup>(1)</sup>, L. V. Gatti<sup>(2)</sup> and R. Acosta<sup>(1)</sup>

1. Physics Department, UFSM (Federal University of Santa Maria), Santa Maria, RS, Brazil

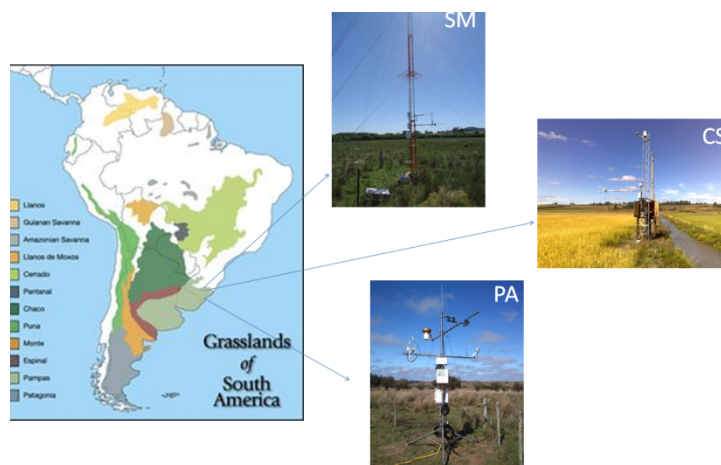
2. IPEN/CQMA/LQA- Nuclear and Energy Research Institute, Sao Paulo, SP, Brazil

### 1. Introduction

The Pampa is the newest and most unknown Brazilian Biome. It is located in the Southern portion of the country, as well as part of Argentina and most of Uruguay. It is formed principally by natural grasslands that have been used for centuries for grazing livestock. In recent decades it has gone through a process of intensive land use change and degradation, with the replacement of natural vegetation by rice paddy crops, soybean and exotic forests. Recent studies show that the Pampa has only 36% of its original vegetation in Brazil. Research on carbon and greenhouse gas emissions in Pampa Biome are recent. It is known that the Pampa natural areas contain high stocks of soil organic carbon and therefore their conservation is relevant for climate change mitigation. However, the carbon net exchange between the surface and the atmosphere are unknown. To fill this gap, a flux tower network was created (SULFLUX – [www.ufsm.br/sulfux](http://www.ufsm.br/sulfux)). Currently, SULFLUX comprises three flux towers in the Pampa biome, two of them being over natural vegetation and the other one over a rice paddy. The flux towers are nearly 100 km apart from each other. We examine the effects of climate on carbon fluxes of through the year 2014. Analysis of temporal variability in CO<sub>2</sub> fluxes is examined at daily to annual scales. Overall, regional variability in climatic drivers, land use and soil proprieties have a considerable effect on carbon net exchange.

### 2. Data and methods

Pampa Biome is located in the Southern Brazil portion, as well as part of Argentina and the entire Uruguay, and is formed principally by natural grasslands that have been used for centuries for grazing livestock. For this study we compare three sites of SULFLUX, two over a natural vegetation (Pampa) and other over a modified land use (rise), for cooperation of difference of greenhouse gas emissions for those sites (Figure 1). A difference among those sites is showing in Table 1.



**Figure 1. Location of the flux towers in the PAMPA BIOME in Southern Brazil: (a) CS - Cachoeira do Sul - Rice Paddy; (b) PA - Pedras Altas - cattle pasture without paddocks; (c) SM- Santa Maria- cattle pasture in paddocks**

**Table 1. Sites description**

<i>Site</i>	<i>CS</i>	<i>PA</i>	<i>SM</i>
<i>City - state (Brazil)</i>	Cachoeira do Sul - RS	Pedras Altas - RS	Santa Maria - RS
<i>Altitude (m)</i>	40.5	375	88
<i>Vegetation</i>	Rice Paddy	Natural vegetation	Natural vegetation
<i>Soil type</i>	Clayey Red Dystrophic	Clayey Red Yellow Dystrophic	Clayey Red Dystrophic
<i>Soil texture</i>	Average to clay	Average	clay
<i>Precipitation [mm]</i>	2000	1350	1617
<i>Tar (Tmax eTmin) [°C]</i>	19 (17, 28)	17 (13, 20)	20 (14, 25)
<i>Period measures</i>	10 oct 2009 - current	29 sep 2013 - current	20 nov 2013 - current
<i>Coordinates(Longitude, Latitude) [°]</i>	-53,1479; -30,2771	-53,5339; -31,7258	-53,7597; -29,7241

The instrumentation of the towers have standard atmospheric measurements and measurements of temperature and moisture in the soil, more information on [www.ufsm.br/sulfux](http://www.ufsm.br/sulfux). To obtain the greenhouse (carbon dioxide) flux between the atmosphere and an ecosystem, the eddy covariance technique was used. For the application of this technique a high frequency measurement of vertical wind component and carbon dioxide concentration is necessary. These values were measured in 3 meters height by infra-red gas analyzer (LI-7200, Li-Cor) and sonic anemometer (Wind Master Pro, Gill Instruments) for Santa Maria (SM) site and infra-red gas analyzer (LI-7500, Li-Cor) and sonic anemometer (CSAT 3, Campbell Scientific) for Cachoeira do Sul (CS) and Pedras Altas (PA).

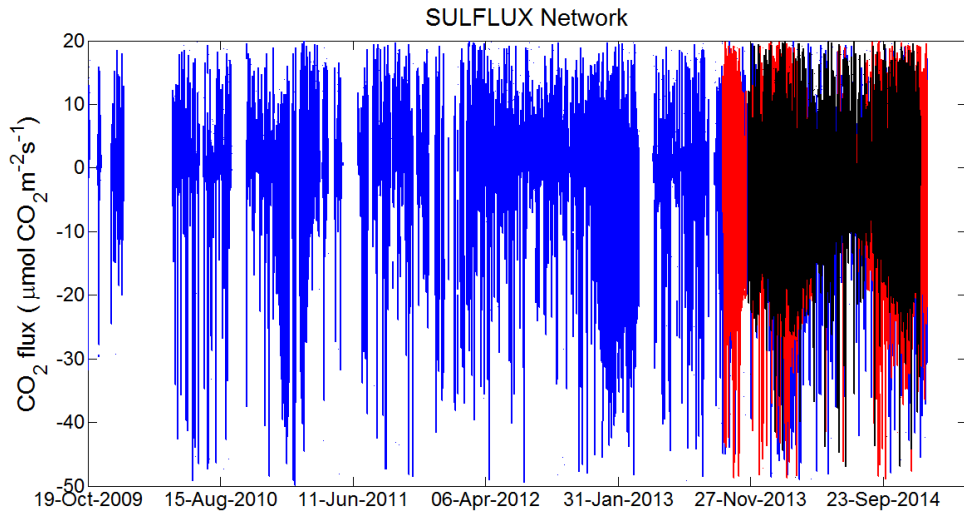
The CO<sub>2</sub> flux was estimated using the Eddy Covariance Method (EC) with the software EddyPro®, versão 5.1.1, Li-Cor (Lincoln, Nebraska, EUA). Data processing of flux carbon dioxide were corrected for inadequate sensor frequency response following standard methods, including despiking, coordinate rotation and air density corrections [Moncrieff, 2004; Wilczak et al., 2001; Webb et al., 1980]. Eddy covariance data were processed to determine net ecosystem exchange of CO<sub>2</sub> (NEE,  $\mu\text{mol CO}_2 \text{ m}^{-2} \text{ s}^{-1}$ ) over 30-minute time intervals. The half-hourly data were then filtered to remove periods with biologically impossible values of NEE ( $< -50 \mu\text{mol CO}_2 \text{ m}^{-2} \text{ s}^{-1}$  or  $> 20 \mu\text{mol CO}_2 \text{ m}^{-2} \text{ s}^{-1}$ ). No gap filling was performed.

### 3. Results

The half hour CO<sub>2</sub> flux for three sites in Southern Brazil are showed in Figure 2 for entire period of data. We can see a seasonality in CO<sub>2</sub> flux in all sites. In PA and SM, this seasonality is driving by solar radiation variability. However, in CS the seasonality appears principally because the rice growing season, negative values indicate CO<sub>2</sub> absorbed.

To compare the three sites, the annual mean and the mean daily cycle of CO<sub>2</sub>, solar radiation ( $R_g$ ) and air temperature (T) of each site for the year 2014 is present in Table 2 and Figure 3. The natural fields, with cattle pasture present similar behaviour (PA and SM). The solar radiation variability in PA and SM sites, seems to have more influence in CO<sub>2</sub> flux rather than temperature. The crop cultivation (rice paddy in CS) present a small day/night amplitude in the mean daily cycle, but, there are a large difference between growing season and fallow periods (Figure 2).

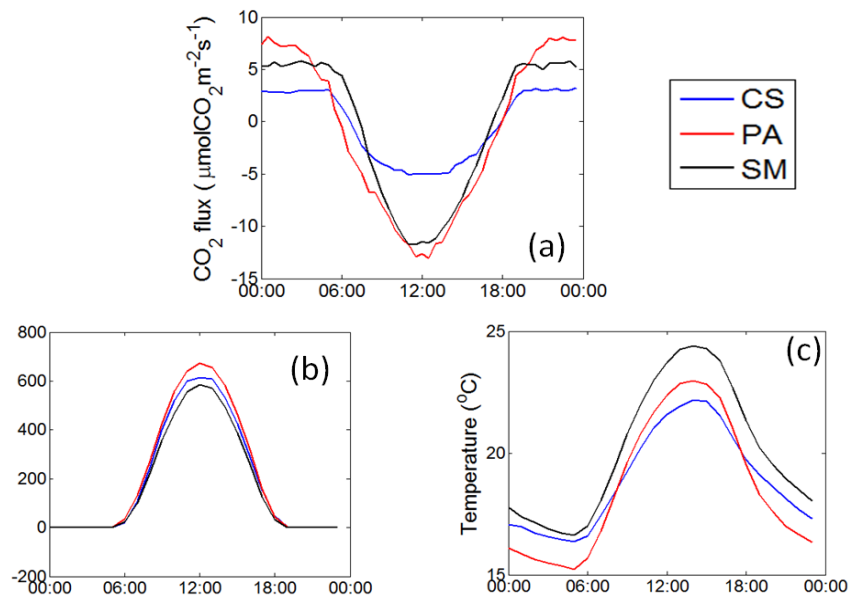




**Figure 2. Half hour CO<sub>2</sub> flux for CS (blue), PA (Red) and SM (black) sites in Southern Brazil.**

**Table 2. Annual mean (for the year 2014) of CO<sub>2</sub> flux, solar radiation ( $R_g$ ) and Temperature (T) for the sites in Southern Brazil**

	CO <sub>2</sub> ( $\mu\text{mol m}^{-2} \text{s}^{-1}$ ) <sub>1)</sub>	$R_g$ ( $\text{W m}^{-2}$ )	T ( $^{\circ}\text{C}$ )
<b>CS</b>	- 0.294	698.0	18.9
<b>PA</b>	- 0.909	750.4	18.6
<b>SM</b>	- 0.329	626.2	20.1



**Figure 3. Annual mean of the daily cycle for (a) CO<sub>2</sub> flux, (b) solar radiation and (c) air temperature for CS, PA and SM sites in Southern Brazil**

#### 4. Conclusion

The preliminary results (we do not use the gap filling techniques) indicate the PAMPA Biome absorbs  $0.51 \mu\text{mol.CO}_2.\text{m}^{-2}.\text{s}^{-1}$  or  $693 \text{ g.CO}_2.\text{m}^{-2}.\text{year}^{-1}$  or  $193 \text{ g.C-CO}_2.\text{m}^{-2}.\text{year}^{-1}$ . The variability in climatic drivers, land use and soil properties have a considerable effect on net carbon exchange.

#### References

- Moncrieff, J.B., R. Clement, J. Finningan and T. Meyers, 2004: Averaging, detrending and filtering of eddy covariance time series, in Handbook of micrometeorology: a guide for surface flux measurements, (eds. Lee, X., W.J. Massman and B.E. Law), Dordrecht: Kluwer Academic, 7-31.
- Webb, E.K., G.I. Pearman and R. Leuning, 1980: Correction of flux measurements for density effects due to heat and water vapor transfer, *Quarterly Journal of the Royal Meteorological Society*, 106: 85–100.
- Wilczak, J.M., S.P. Oncley and S.A. Stage, 2001: A. Sonic anemometer tilt correction algorithms, *Boundary-Layer Meteorology*, 99: 127-150.
-

## GGMT-2015 IZAÑA STATION UPDATE: INSTRUMENTAL AND PROCESSING SOFTWARE DEVELOPMENTS, SCALE UPDATES, AIRCRAFT CAMPAIGN, AND PLUMBING DESIGN FOR CRDS

Angel J. Gomez-Pelaez<sup>1</sup>, Ramon Ramos<sup>1</sup>, Vanessa Gomez-Trueba<sup>1,2</sup>, Ruben Campo-Hernandez<sup>1</sup> and Enrique Reyes-Sanchez<sup>1</sup>

1. Izaña Atmospheric Research Center (IARC), Meteorological State Agency of Spain (AEMET), Tenerife, Spain
2. Air Liquide España, Delegación Canarias, Tenerife, Spain

### 1. Introduction

Izaña observatory (IZO) is a GAW Global station located at 2373 m a.s.l. on Tenerife (Canary Islands, Spain). In situ measurements at Izaña are representative of the subtropical Northeast Atlantic free troposphere, especially during the night-time period. Several atmospheric greenhouse gases (CO<sub>2</sub>, CH<sub>4</sub>, N<sub>2</sub>O and SF<sub>6</sub>; and the related tracer CO) are measured in situ and continuously at this station. The recently published WMO/GAW Report No. 219, "Izaña Atmospheric Research Center Activity Report 2012-2014" (Cuevas et al., 2015), provides detailed information about the different measurement programmes of this supersite. This report is available at the WMO/GAW website:

[http://www.wmo.int/pages/prog/arep/gaw/documents/Final\\_GAW\\_Report\\_No\\_219.pdf](http://www.wmo.int/pages/prog/arep/gaw/documents/Final_GAW_Report_No_219.pdf)

In the present GGMT-2015 contribution, we summarize the more relevant facts and novelties concerning the IZO GHG in situ measurement programme that have happened since GGMT-2013.

Izaña GAW Global station continues submitting data to the WDCGG for these 5 GHGs (and related tracer) and participating in the data products GLOBALVIEW and OBSPACK led by NOAA-ESRL-GMD-CCGG.

From the end of September 2013 till the beginning of February 2014, GAW WCC-EMPA conducted a scientific audit at Izaña station (see Zellweger et al., 2015). That was the first IZO GHG audit in which a travelling instrument has been used (additionally to the usual measurements of travelling standards) to measure ambient air during several months in parallel with the in situ IZO GHG measurements.

Izaña has also participated in the 6<sup>th</sup> WMO/IAEA Round Robin Comparison Experiment. We received the two round robin cylinders of Circuit 1 in July 2015, measured them for CO<sub>2</sub>, CH<sub>4</sub>, N<sub>2</sub>O, SF<sub>6</sub> and CO, shipped them back to NOAA, and reported the measurement results using the dedicated Round Robin website. The results of this inter-comparison were made public on 9 September 2015 (<http://www.esrl.noaa.gov/gmd/ccgg/wmorr/>).

### 2. Instrumental and processing software developments

In October 2013, we installed a new system of UV lamp (kindly provided by the Carbon Cycle Group of the Institute of Environmental Physics of the University of Heidelberg) in the IZO RGA-3, because spare UV lamps for this old instrument were not being manufactured any longer. This system developed by the cited institution is based on cheap commercial UV lamps for aquariums. In September 2014, a new electronic for controlling the injection valve of this instrument was installed (the previous one had been faulting occasionally). On September 3, 2015, we installed a flow controller downstream the gas multi-position selection valve.

At the end of 2013 we began to perform occasional tests of air tightness to the dedicated inlet lines of the GHG measurement systems by capping the ends of the line, evacuating part of the air inside of the line and measuring the subsequent pressure increase rate. In May 2014, 7-

micrometre filters were installed in all the dedicated inlet lines of the GHG measurement systems. In 2014, permanent vents were introduced downstream of all the pumps (to decrease the pump downstream pressure). In May 2014, we installed a system to evaporate quickly (by continuous high flow-rate flushing, using pumped free troposphere air) all the liquid water content of the flasks not being used at a given moment by the cryocoolers. In February 2015, electronic pressure sensors were installed in those vents and electronic temperature sensors were installed in the cryocooled baths (additionally to the thermometer used by the control system of each cryocooler) and in the ambient air of the two IZO GHG labs, and all their measurements acquired (still under development).

In December 2013, IZO was severely hit by lightning associated to severe thunderstorms. The IZO GC-FID Dani was damaged. The IZO GC-FID Varian has been our primary CH<sub>4</sub> instrument since January 2014. During the first half of 2014 we repaired the GC Dani and introduced many changes in it: 1) use of a stainless steel dedicated ambient inlet line; 2) the carrier gas is N<sub>2</sub> (instead of the synthetic air historically used at IZO); 3) a new injection valve was installed (Valco); 4) column oven at 69 °C; 5) installation of a flow controller downstream the gas multi-position selection valve; 6) installation of a permanent vent downstream the dedicated pump and a low-flow vent downstream the dedicated cryotrap (and equalization of sample loop flushing times); and 7) substitution of the acquisition shielded wire.

At the beginning of February 2014, the IZO NDIR Li-7000 broke down (IZO primary CO<sub>2</sub> instrument). We sent it to Germany for being repaired. From that date till middle May 2014, the IZO NDIR Li-6252 was used as IZO primary CO<sub>2</sub> instrument. When the Li-7000 returned repaired (beginning of May 2014), we introduced some changes in its inlet system: 1) a vent was installed downstream of the dedicated pump and we removed the two solenoid valves of the ambient air inlet (V0 and V1 of Figure 1 of Gomez-Pelaez et al., 2011) and connected this line to a port of the MPV and the MFC1 to the outlet port of the MPV (the notation follows the cited figure); 2) after that date the data processing software discards 6 minutes of ambient air measurement every hour just after the measurement of the working standards (while the flask of the cryocooler is flushed). The same changes were applied to the Li-6252 measurement system on June 4, 2014.

During the first half of 2014 we introduced some **changes in the IZO GC-FID-ECD Varian:** 1) at the beginning of February 2014, a permanent vent downstream of the dedicated pump and a low-flow vent downstream of the dedicated cryotrap (and equalization of sample loop flushing times) were installed; 2) in June 2014, we installed a new sample-loop selection valve (of rotary type) instead of the 3-way solenoid valve that had been used previously (valve V4 of Figure 1 of Gomez-Pelaez et al., 2009), and two independent flow controllers downstream of the two outlets of this selection valve (instead of the previously used unique flow controller upstream of this valve).

We have developed software in Fortran 90 to process approximately in quasi-real time the raw data to obtain provisional mole fractions for the NDIR Li-6252, GC-ECD and RGA-3 (for the rest of the IZO GHG instruments such software was developed some years ago). We have developed scripts to load such quasi-real time data into a database and then such data is graphically showed in IZO intranet pages for early internal diagnostic (still under development).

We have developed software in Fortran 90 to compute very accurately ambient air mole fraction from raw data and the hierarchy of calibrations, for the IZO secondary CO<sub>2</sub> measurement system (based on a Li-6252, which was temporarily the IZO CO<sub>2</sub> primary system during most of the first half of 2014) and for the IZO GC-FID Varian measurement system (this system has been the primary system for IZO CH<sub>4</sub> since January 2014). The ambient air processing data scheme used for the IZO Li-6252 is very similar to that previously developed for the Li-7000 (described in Section 2 of Gomez-Pelaez et al., 2011). Also, some small refinements have been introduced in the cited Li-7000 ambient air processing software (i.e., for the mean parameters  $\langle a_3/a_2 \rangle$  and  $\langle a_4 \rangle$  used in Eq. 2 of Gomez-Pelaez et al., 2011,

the computation of the former is now performed dividing in -time interval- subsets the global set of calibrations –a different mean is used for each time interval-, whereas the later parameter is now considered as linearly dependent on temperature; small increase of the time period of ambient air measurement discarding every hour just after the measurement of the working standards,...).

We are purchasing the necessary material to introduce improvements in the dedicated inlet lines: 1) back-pressure regulators for the vents located downstream the pumps and rotameters for those vents; 2) needle valves to be used in low flow vents to be installed downstream the cryotrap; 3) glass flask cryotrap with Ultra-Torr connections; 4) secondary small stainless steel traps; 5) hermetic plugs for unused ports of the rotary Valco valves; 6) additional filters; and 7) high quality tubing for building GC sample loops.

### 3. Scale updates, recalibration of IZO laboratory standards at GAW CCL (NOAA), and accounting for the drift of one of the IZO CO laboratory standards

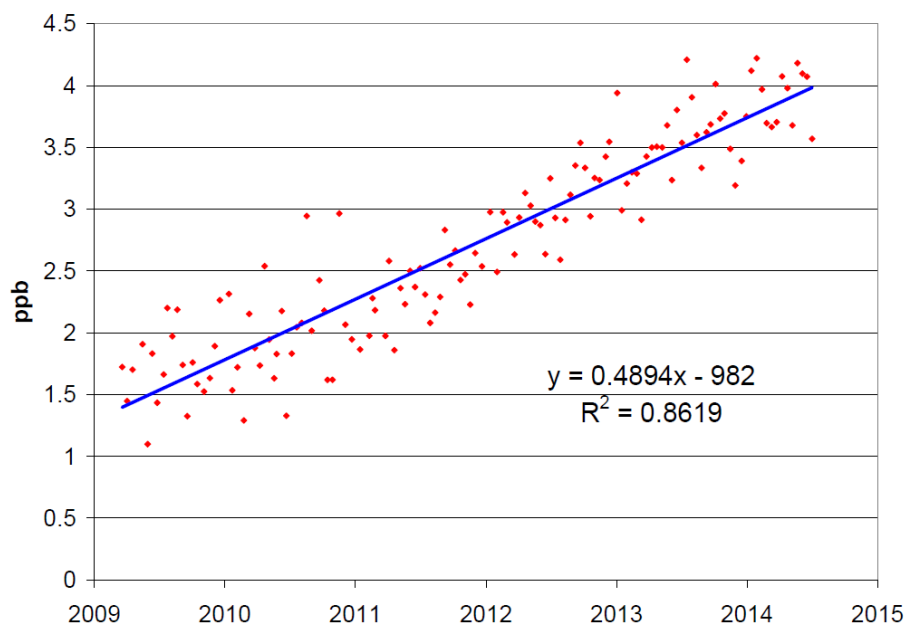
Table 1 shows the set of laboratory standards (prepared and calibrated by GAW CCLs) used currently as IZO "primaries". All of them have been recalibrated at NOAA during the second half of 2014 and the first half of 2015 (sent in two independent shipments not overlapping in time). However, one of the N<sub>2</sub>O/SF<sub>6</sub> standards was purchased in 2014 (that written using underlined cursive in the table). None of IZO laboratory standards have significantly (in the statistical sense) drifted along years, except one of the CO laboratory standards.

**Table 1. Set of laboratory standards used currently as IZO "primaries" for the different greenhouse gases (and carbon monoxide), drift assessment, current scale for ambient measurements, and period of in situ ambient air measurements. A red asterisk means that this scale has been implemented by us at IZO in 2015 in the way described in the main text. Note + : the data submitted to the WDCGG for the year 2014 has been obtained using a Varian-3800 GC-FID (for the previous year a Dani-3800 GC-FID was used). Note ++ : in 2015 the full CO time series has been reprocessed (and re-submitted to the WDCGG) taking into account the drift of one of the laboratory standards and the IZO internal recalibrations of the standards used in 2008.**

Molecule	Number of standards and serial numbers	¿Statistically significant drift?	Current scale used at IZO for in situ ambient measurements	Period of in situ ambient measurements
<b>CO<sub>2</sub></b>	<b>6</b> (CA06905, CA07421, CA02839, CA07969, CA06817, CA06800)	<b>NO</b>	WMO X2007 *	1984-present
<b>CH<sub>4</sub></b>	<b>3</b> (CA08201, CA06930, CA06932)	<b>NO</b>	NOAA-2004	1984-present +
<b>N<sub>2</sub>O</b>	<b>6</b> (CA06739, CA06970, CA08203, CA06996, CA06964, <u>CB10914</u> )	<b>NO</b>	NOAA-2006A *	2007-present
<b>SF<sub>6</sub></b>	<b>6</b> (CA06739, CA06970, CA08203, CA06996, CA06964, <u>CB10914</u> )	<b>NO</b>	WMO X2014 *	2007-present
<b>CO</b>	<b>5</b> (CA06768, CA06946, CA06988, CA06968, CA06978)	<b>NO except CA06946</b>	WMO X2004	2008-present ++

A scale with a red asterisk means that this scale (the latest released by GAW CCL for this gas) has been implemented by us at IZO in 2015, in the way described as follows: 1) the mole fraction of each laboratory standard in this new WMO scale has been assigned as the mean (weighted in reproducibility in case the reproducibility of the GAW CCL has changed significantly along the years) of the CCL calibrations for such standard (for CO<sub>2</sub>, we have also taken into account the internal re-calibrations of old laboratory standards against our current laboratory standards); 2) all the previous IZO instrumental and working standard calibrations have been reprocessed taking into account the new mole fractions assigned to the IZO laboratory standards; 3) all the previous ambient air measurements have been re-evaluated using the new time series of instrumental responses and working standard mole fraction assignments, and re-submitted to the WDCGG (for CO<sub>2</sub>, this process has been performed only for the data period 2007-present).

Concerning the CO drifting standard (CA06946), there is a statistically significant difference between the re-calibration performed by the CCL during the second half of 2014 and the original calibration performed by CCL at the beginning of 2006. However, the CO calibration results are provided by the CCL at present in the WMO X2014 scale. This scale has still unresolved problems of stability, and it is not recommended yet to perform the change to this new scale. Therefore, we have proceeded as follows for determining the drift rate of the drifting standard: 1) we continue using the original mole fractions for the 4 no-drifting standards (in scale X2004); 2) we have reprocessed all the previous IZO RGA-3 CO calibrations using the set of 4 no-drifting standards as calibration standards and the drifting standard as tank being calibrated in such calibrations. See the increment of mole fraction – above the original value assigned by the CCL- obtained for that standard along its lifetime in Figure 1. This figure also shows the least-square fit of these calibration results to a linear drift in time, the equation of such straight line and the coefficient of determination ( $R^2$ ) of the fit. The drift rate of this laboratory standard is equal to 0.489 ppb/year. This result is consistent with the provisional re-calibration result obtained by the CCL.



**Figure 1. Increment of mole fraction –above the original value assigned by the CCL- obtained for the IZO CO laboratory standard CA06946 along its lifetime from the bi-weekly RGA-3 calibrations performed at IZO (using as calibrators the 4 other non-drifting IZO CO laboratory standards).**

The combined impact (new value minus old value; in absolute value) of the scale updates we have recently implemented as well as of the internal recalibrations of old laboratory standards, drift in one CO laboratory standard, slight data processing software modifications... on the new IZO CO<sub>2</sub>, N<sub>2</sub>O, SF<sub>6</sub> and CO time series re-submitted to the WDCGG is:  $\leq 0.04$  ppm for CO<sub>2</sub>,  $\leq 1.4$  ppb for CO,  $\leq 0.11$  ppb for N<sub>2</sub>O, and  $\leq 0.012$  ppt for SF<sub>6</sub> (where we have compared the monthly means to quantify the impact).

We add here a note concerning the CO working standards used at Izaña observatory (we fill and calibrate at IZO all the working standards used) to complement what was exposed in the first paragraph of page 790 of Gomez-Pelaez et al. 2013. We use 20-L cylinders obtained from Air Liquide Spain to contain the working standards of CO<sub>2</sub>, CH<sub>4</sub>, N<sub>2</sub>O, SF<sub>6</sub> and CO. If we find that a CO<sub>2</sub> working standard drifts too much along its lifetime of several months (i.e., total drift larger than 0.2 ppm), then, in the following, the corresponding cylinder is only used to create CO working standards (because the laboratory relative compatibility required by GAW for CO is much less stringent than for the greenhouse gases measured at IZO). Therefore, at IZO, the CO working standards are contained in the worst behaved IZO cylinders.

#### 4. Aircraft campaign

After GGMT-2013 we finished adapting the IZO GHG in situ measurement systems to be able to measure also discrete samples collected on board aircrafts using a quasi automatic sampler (a Programmable Compressor Package –PCP– with a Programmable Flask Package –FPF–, both designed and routinely used by NOAA-ESRL-GMD-CCGG) and tested the sample extraction, distribution and measurement system. We participated in the MUSICA (project led by the Karlsruhe Institute of Technology) – AMISOC (project led by the National Institute of Aerospace Technique of Spain –INTA–) aircraft campaign: 7 scientific flights (using the INTA's research aircraft C-212) were carried out between 21th July and 1st August 2013 above the ocean to the south of IZO, freighting on board instrumentation of both projects (for the measurement of isotopes in water vapour and of aerosols).

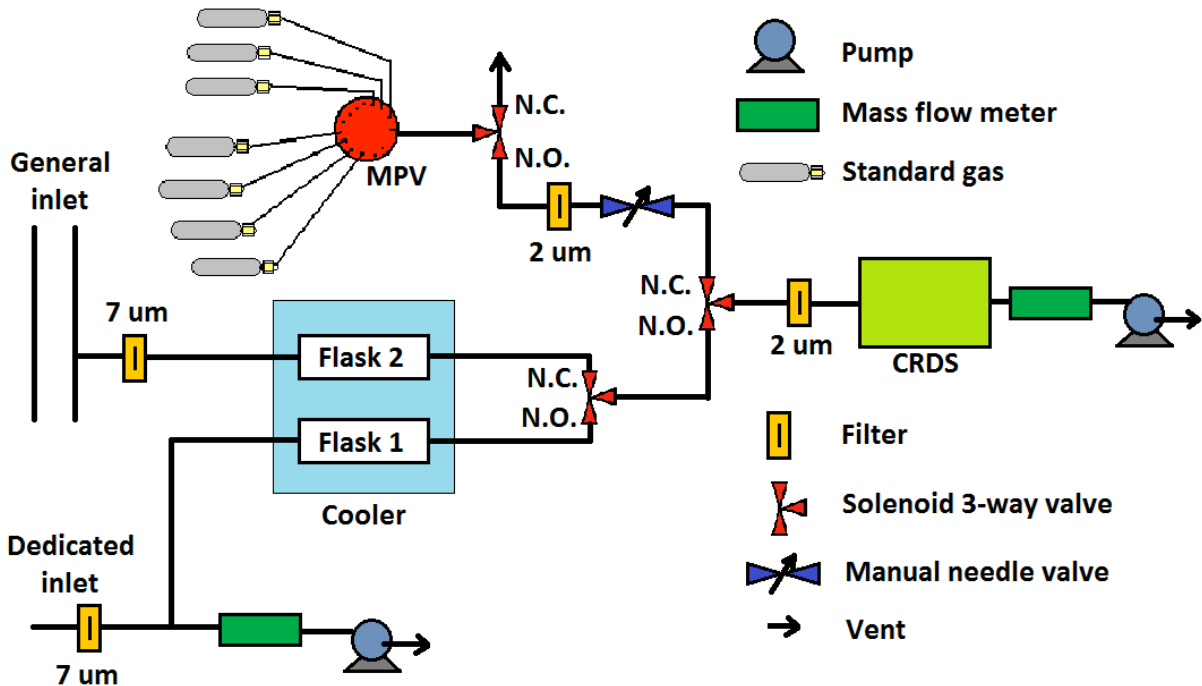
We took the opportunity to install on board this aircraft by first time our quasi automatic air sampler (see Figure 2). In each flight, the sampler was used to take twelve air samples from different altitudes uniformly distributed from the 150 metres to the 6500 metres altitude levels. The greenhouse gases content of these samples was analysed latter at Izaña Observatory. We plan to publish a paper about these measurements in the near future.



**Figure 2. Left picture: quasi automatic air sampler installed on board the INTA's aircraft. Right picture: group picture (crew and some of the technicians and scientists involved in this campaign) and aircraft.**

## 5. Plumbing design for CRDS

We are purchasing a GHG CRDS for IZO. Figure 3 shows a schematic of the plumbing design we have developed for the GHG CRDS we are going to install at IZO, which takes advantage of the fact that there are technical personnel at the station everyday. We are going to partially dry the ambient air to be analysed by using a flask immersed in a cold bath (at around  $-30^{\circ}\text{C}$ ). Two ambient inlets will be used for the CRDS: 1) one coming from one of the two IZO general inlets, and 2) a dedicated Synflex 1300 3/8" O.D. line coming from the top of the IZO tower. The CRDS lines coming from the IZO general inlet manifold and from the CRDS dedicated-inlet tee will be 1/4" O.D. There will be a cryocooled flask (with Ultra-Torr connections) for each of these lines. A solenoid 3-way valve will select the line in use (there will be alternation). The laboratory standards and target gases will be connected to a rotary multi-position valve (MPV). The laboratory standard cylinder valves will be usually close and only opened when performing a calibration (this is probably beneficial to keep the mole fractions of the laboratory standards stable). The purpose of the solenoid valve located downstream of the MPV is to vent the gas coming from flushing the laboratory standard regulators before starting a calibration. In order to get the same pressure in the inlet of the CRDS when measuring standards and ambient air, a needle valve will be used to decrease the pressure of the gas coming from the MPV. In order to minimize the difference between the ambient pressure and the inlet pressure at the opening of the CRDS when measuring ambient air, a 3/8" O.D. Synflex 1300 line will be used for the CRDS dedicated inlet (with a length of around 25 metres). Anyway, the water vapour corrections will be determined using the water drop method (the error of these corrections will be negligible since ambient air will be quite dry after flowing through the cryotrap).



**Figure 3. Schematic of the plumbing design we have developed to install a CRDS next year at IZO**



## References

- Cuevas, E., C. Milford, J.J. Bustos, R. del Campo-Hernández, O.E. García, R.D. García, A.J. Gómez-Peláez, R. Ramos, A. Redondas, E. Reyes, S. Rodríguez, P.M. Romero-Campos, M. Schneider, J. Belmonte, M. Gil-Ojeda, F. Almansa, S. Alonso-Pérez, A. Barreto, Y. González-Morales, C. Guirado-Fuentes, C. López-Solano, S. Afonso, C. Bayo, A. Berjón, J. Bethencourt, C. Camino, V. Carreño, N.J. Castro, A.M. Cruz, M. Damas, F. De Ory-Ajamil, M.I. García, C.M. Fernández-de Mesa, Y. González, C. Hernández, Y. Hernández, M.A. Hernández, B. Hernández-Cruz, M. Jover, S.O. Kühl, R. López-Fernández, J. López-Solano, A. Peris, J.J. Rodríguez-Franco, C. Sálamo, E. Sepúlveda and M. Sierra, 2015: *Izaña Atmospheric Research Center Activity Report 2012-2014*, (Eds. Cuevas, E., Milford, C. and Tarasova, O.), State Meteorological Agency (AEMET), Madrid, Spain and World Meteorological Organization, Geneva, Switzerland, NIPO: 281-15-004-2, WMO/GAW Report No. 219.
- Gomez-Pelaez, A.J., and R. Ramos, 2009: "Installation of a new gas chromatograph at Izaña GAW station (Spain) to measure CH<sub>4</sub>, N<sub>2</sub>O, and SF<sub>6</sub>" in GAW Report (No. 186) of the "14th WMO/IAEA meeting of experts on Carbon dioxide, other greenhouse gases, and related tracers measurement techniques (Helsinki, Finland, 10-13 September 2007)", edited by Tuomas Laurila, World Meteorological Organization (TD No. 1487), Geneva, Switzerland, 55-59.
- Gomez-Pelaez, A.J. and R. Ramos, 2011: "Improvements in the Carbon Dioxide and Methane Continuous Measurement Programs at Izaña Global GAW Station (Spain) during 2007-2009", in GAW Report (No. 194) of the "15th WMO/IAEA Meeting of Experts on Carbon Dioxide, Other Greenhouse Gases, and Related Tracer Measurement Techniques (Jena, Germany; September 7-10, 2009)", edited by Willi A. Brand, World Meteorological Organization (TD No. 1553), Geneva, Switzerland, 133-138.
- Gomez-Pelaez, A. J., R. Ramos, V. Gomez-Trueba, P.C. Novelli and R. Campo-Hernandez, 2013: A statistical approach to quantify uncertainty in carbon monoxide measurements at the Izaña global GAW station: 2008–2011, *Atmospheric Measurement Techniques*, 6, 787-799, doi:10.5194/amt-6-787-2013.
- Zellweger, C., M. Steinbacher, B. Buchmann, R. Steinbrecher, 2015: *System and Performance Audit of Surface Ozone, Methane, Carbon Dioxide, Nitrous Oxide and Carbon Monoxide at the Global GAW Station Izaña*, September 2013. WCC-Empa Report 13/2, [http://gaw.empa.ch/audits/IZO\\_2013.pdf](http://gaw.empa.ch/audits/IZO_2013.pdf)
-



### LIST OF RECENT GLOBAL ATMOSPHERE WATCH REPORTS\*

149. Comparison of Total Ozone Measurements of Dobson and Brewer Spectrophotometers and Recommended Transfer Functions (prepared by J. Staehelin, J. Kerr, R. Evans and K. Vanicek) (WMO TD No. 1147).
150. Updated Guidelines for Atmospheric Trace Gas Data Management (Prepared by Ken Maserie and Pieter Tans (WMO TD No. 1149).
151. Report of the First CAS Working Group on Environmental Pollution and Atmospheric Chemistry (Geneva, Switzerland, 18-19 March 2003) (WMO TD No. 1181).
152. Current Activities of the Global Atmosphere Watch Programme (as presented at the 14<sup>th</sup> World Meteorological Congress, May 2003). (WMO TD No. 1168).
153. WMO/GAW Aerosol Measurement Procedures: Guidelines and Recommendations. (WMO TD No. 1178) (superseded by GAW Report No. 227)
154. WMO/IMEP-15 Trace Elements in Water Laboratory Intercomparison. (WMO TD No. 1195).
155. 1<sup>st</sup> International Expert Meeting on Sources and Measurements of Natural Radionuclides Applied to Climate and Air Quality Studies (Gif sur Yvette, France, 3-5 June 2003) (WMO TD No. 1201).
156. Addendum for the Period 2005-2007 to the Strategy for the Implementation of the Global Atmosphere Watch Programme (2001-2007), GAW Report No. 142 (WMO TD No. 1209).
157. JOSIE-1998 Performance of EEC Ozone Sondes of SPC-6A and ENSCI-Z Type (Prepared by Herman G.J. Smit and Wolfgang Straeter) (WMO TD No. 1218).
158. JOSIE-2000 Jülich Ozone Sonde Intercomparison Experiment 2000. The 2000 WMO international intercomparison of operating procedures for ECC-ozone sondes at the environmental simulation facility at Jülich (Prepared by Herman G.J. Smit and Wolfgang Straeter) (WMO TD No. 1225).
159. IGOS-IGACO Report - September 2004 (WMO TD No. 1235), 68 pp, September 2004.
160. Manual for the GAW Precipitation Chemistry Programme (Guidelines, Data Quality Objectives and Standard Operating Procedures) (WMO TD No. 1251), 186 pp, November 2004.
161. 12<sup>th</sup> WMO/IAEA Meeting of Experts on Carbon Dioxide Concentration and Related Tracers Measurement Techniques (Toronto, Canada, 15-18 September 2003), 274 pp, May 2005.
162. WMO/GAW Experts Workshop on a Global Surface-Based Network for Long Term Observations of Column Aerosol Optical Properties, Davos, Switzerland, 8-10 March 2004 (edited by U. Baltensperger, L. Barrie and C. Wehrli) (WMO TD No. 1287), 153 pp, November 2005.
163. World Meteorological Organization Activities in Support of the Vienna Convention on Protection of the Ozone Layer (WMO No. 974), 4 pp, September 2005.

---

\* (A full list is available at <http://www.wmo.int/pages/prog/arep/gaw/gaw-reports.html>)

164. Instruments to Measure Solar Ultraviolet Radiation: Part 2: Broadband Instruments Measuring Erythemally Weighted Solar Irradiance (WMO TD No. 1289), 55 pp, July 2008, electronic version 2006.
165. Report of the CAS Working Group on Environmental Pollution and Atmospheric Chemistry and the GAW 2005 Workshop, 14-18 March 2005, Geneva, Switzerland (WMO TD No. 1302), 189 pp, March 2005.
166. Joint WMO-GAW/ACCENT Workshop on The Global Tropospheric Carbon Monoxide Observations System, Quality Assurance and Applications (EMPA, Dübendorf, Switzerland, 24 – 26 October 2005) (edited by J. Klausen) (WMO TD No. 1335), 36 pp, September 2006.
167. The German Contribution to the WMO Global Atmosphere Watch Programme upon the 225<sup>th</sup> Anniversary of GAW Hohenpeissenberg Observatory (edited by L.A. Barrie, W. Fricke and R. Schleyer (WMO TD No. 1336), 124 pp, December 2006.
168. 13<sup>th</sup> WMO/IAEA Meeting of Experts on Carbon Dioxide Concentration and Related Tracers Measurement Techniques (Boulder, Colorado, USA, 19-22 September 2005) (edited by J.B. Miller) (WMO TD No. 1359), 40 pp, December 2006.
169. Chemical Data Assimilation for the Observation of the Earth's Atmosphere – ACCENT/WMO Expert Workshop in support of IGACO (edited by L.A. Barrie, J.P. Burrows, P. Monks and P. Borrell) (WMO TD No. 1360), 196 pp, December 2006.
170. WMO/GAW Expert Workshop on the Quality and Applications of European GAW Measurements (Tutzing, Germany, 2-5 November 2004) (WMO TD No. 1367).
171. A WMO/GAW Expert Workshop on Global Long-Term Measurements of Volatile Organic Compounds (VOCs) (Geneva, Switzerland, 30 January – 1 February 2006) (WMO TD No. 1373), 36 pp, February 2007.
172. WMO Global Atmosphere Watch (GAW) Strategic Plan: 2008 – 2015 (WMO TD No. 1384), 108 pp, August 2008.
173. Report of the CAS Joint Scientific Steering Committee on Environmental Pollution and Atmospheric Chemistry (Geneva, Switzerland, 11-12 April 2007) (WMO TD No.1410), 33 pp, June 2008.
174. World Data Centre for Greenhouse Gases Data Submission and Dissemination Guide (WMO TD No. 1416), 50 pp, January 2008.
175. The Ninth Biennial WMO Consultation on Brewer Ozone and UV Spectrophotometer Operation, Calibration and Data Reporting (Delft, Netherlands, 31-May – 3 June 2005) (WMO TD No. 1419), 69 pp, March 2008.
176. The Tenth Biennial WMO Consultation on Brewer Ozone and UV Spectrophotometer Operation, Calibration and Data Reporting (Northwich, United Kingdom, 4-8 June 2007) (WMO TD No. 1420), 61 pp, March 2008.
177. Joint Report of COST Action 728 and GURME – Overview of Existing Integrated (off-line and on-line) Mesoscale Meteorological and Chemical Transport Modelling in Europe (ISBN 978-1-905313-56-3) (WMO TD No. 1427), 106 pp, May 2008.
178. Plan for the implementation of the GAW Aerosol Lidar Observation Network GALION, (Hamburg, Germany, 27 - 29 March 2007) (WMO TD No. 1443), 52 pp, November 2008.

179. Intercomparison of Global UV Index from Multiband Radiometers: Harmonization of Global UVI and Spectral Irradiance (WMO TD No. 1454), 61 pp, March 2009.
180. Towards a Better Knowledge of Umkehr Measurements: A Detailed Study of Data from Thirteen Dobson Intercomparisons (WMO TD No. 1456), 50 pp, December 2008.
181. Joint Report of COST Action 728 and GURME – Overview of Tools and Methods for Meteorological and Air Pollution Mesoscale Model Evaluation and User Training (WMO TD No. 1457), 121 pp, November 2008.
182. IGACO-Ozone and UV Radiation Implementation Plan (WMO TD No. 1465), 49 pp, April 2009.
183. Operations Handbook – Ozone Observations with a Dobson Spectrophotometer (WMO TD No. 1469), 91 pp, March 2009.
184. Technical Report of Global Analysis Method for Major Greenhouse Gases by the World Data Center for Greenhouse Gases (WMO TD No. 1473), 29 pp, June 2009.
185. Guidelines for the Measurement of Methane and Nitrous Oxide and their Quality Assurance (WMO TD No. 1478), 49 pp, September 2009.
186. 14<sup>th</sup> WMO/IAEA Meeting of Experts on Carbon Dioxide, Other Greenhouse Gases and Related Tracers Measurement Techniques (Helsinki, Finland, 10-13 September 2007) (WMO TD No. 1487), 31 pp, April 2009.
187. Joint Report of COST Action 728 and GURME – Review of the Capabilities of Meteorological and Chemistry-Transport Models for Describing and Predicting Air Pollution Episodes (ISBN 978-1-905313-77-8) (WMO TD No. 1502), 69 pp, December 2009, electronic version - July 2009.
188. Revision of the World Data Centre for Greenhouse Gases Data Submission and Dissemination Guide (WMO TD No.1507), 55 pp, November 2009.
189. Report of the MACC/GAW Session on the Near-Real-Time Delivery of the GAW Observations of Reactive Gases, Garmisch-Partenkirchen, Germany, 6-8 October 2009, (WMO TD No. 1527), 31 pp. August 2010.
190. Instruments to Measure Solar Ultraviolet Radiation Part 3: Multi-channel filter instruments (lead author: G. Seckmeyer) (WMO TD No. 1537), 55 pp. November 2010.
191. Instruments to Measure Solar Ultraviolet Radiation Part 4: Array Spectroradiometers (lead author: G. Seckmeyer) (WMO TD No. 1538), 43 pp. November 2010.
192. Guidelines for the Measurement of Atmospheric Carbon Monoxide (WMO TD No. 1551), 49 pp, July 2010.
193. Guidelines for Reporting Total Ozone Data in Near Real Time (WMO TD No. 1552), 19 pp, April 2011 (*electronic version only*).
194. 15<sup>th</sup> WMO/IAEA Meeting of Experts on Carbon Dioxide, Other Greenhouse Gases and Related Tracers Measurement Techniques (Jena, Germany, 7-10 September 2009) (WMO TD No. 1553). 330 pp, April 2011.
195. WMO/GAW Expert Workshop on Global Long-term Measurements of Nitrogen Oxides and Recommendations for GAW Nitrogen Oxides Network (Hohenpeissenberg, Germany, 8-9 October 2009) (WMO TD No. 1570), 45 pp, February 2011.

196. Report of the Second Session of the CAS JSC OPAG-EPAC and GAW 2009 Workshop (Geneva, Switzerland, 5-8 May 2009), (WMO TD No. 1577).
197. Addendum for the Period 2012 – 2015 to the WMO Global Atmosphere Watch (GAW) Strategic Plan 2008 – 2015, 57 pp, May 2011.
198. Data Quality Objectives (DQO) for Solar Ultraviolet Radiation Measurements (Part I). Addendum to WMO/GAW Report No. 146 - Quality Assurance in Monitoring Solar Ultraviolet Radiation: State of the Art (*electronic version only*).
199. Second Tropospheric Ozone Workshop. Tropospheric Ozone Changes: observations, state of understanding and model performances (Météo France, Toulouse, France, 11-14 April 2011), 226 pp, September 2011.
200. WMO/GAW Standard Operating Procedures for In-Situ Measurements of Aerosol Mass Concentration, Light Scattering and Light Absorption (Edited by John A. Ogren), 134 pp, October 2011.
201. Quality Assurance and Quality Control for Ozonesonde Measurements in GAW (Prepared by Herman Smit and ASOPOS Panel), 95 pp. October 2014
202. Workshop on Modelling and Observing the Impacts of Dust Transport/Deposition on Marine Productivity (Sliema, Malta, 7-9 March 2011), 50 pp, November 2011.
203. The Atmospheric Input of Chemicals to the Ocean. Rep. Stud. GESAMP No. 84/GAW Report No. 203. 69 pp. (ISSN: 1020-4873).
204. Standard Operating Procedures (SOPs) for Air Sampling in Stainless Steel Canisters for Non-Methane Hydrocarbons Analysis (Prepared by Rainer Steinbrecher and Elisabeth Weiß), 25 pp. September 2012.
205. WMO/IGAC Impacts of Megacities on Air Pollution and Climate, 309 pp. September 2012 (ISBN: 978-0-9882867-0-2).
206. 16<sup>th</sup> WMO/IAEA Meeting of Experts on Carbon Dioxide, Other Greenhouse Gases and Related Tracers Measurement Techniques (GGMT-2011), Wellington, New Zealand, 25-28 October 2011, 67 pp, October 2012.
207. Recommendations for a Composite Surface-Based Aerosol Network, Emmetten, Switzerland, 28-29 April 2009, 66 pp. November 2012.
208. WMO GURME Workshop on Urban Meteorological Observation Design, (Shanghai, China, 11-14 December 2011).
209. Guidelines for Continuous Measurements of Ozone in the Troposphere (Prepared by Ian E. Galbally and Martin G. Schultz), 80 pp, February 2013 (WMO-No. 1110, ISBN: 978-92-63-11110-4).
210. Report of the Third Session of the CAS Joint Scientific Committee of the Open Programme Area Group on Environmental Pollution and Atmospheric Chemistry (JSC OPAG-EPAC), (Geneva, Switzerland, 27-29 April 2011) (*electronic version only*).
211. Rationalizing Nomenclature for UV Doses and Effects on Humans (CIE209:2014/GAW Report No. 211) (ISBN: 978-3-902842-35-0).
212. Standard Operating Procedures (SOPs) for Spectral Instruments Measuring Spectral Solar Ultraviolet Irradiance, 21 pp. June 2014.

213. 17<sup>th</sup> WMO/IAEA Meeting on Carbon Dioxide, Other Greenhouse Gases and Related Tracers Measurement Techniques (GGMT-2013), (Beijing, China, 10 - 13 June 2013), 168 pp. July 2014.
214. Report of the GAW 2013 Symposium and the Fourth Session of the CAS JSC OPAG-EPAC, Geneva, Switzerland, 18-20 March 2013, 82 pp, October 2014.
215. Report of the First Session of the CAS Environmental Pollution and Atmospheric Chemistry Scientific Steering Committee (EPAC SSC), (Geneva, Switzerland, 10-12 June 2014), 32 pp. December 2014.
216. Seventh Intercomparison Campaign of the Regional Brewer Calibration Center Europe (RBCC-E), Lichtklimatisches Observatorium, Arosa, Switzerland, 16-27 July 2012, 106 pp. March 2015.
217. System of Air Quality Forecasting And Research (SAFAR – India), 60 pp. June 2015.
218. Absorption Cross-Sections of Ozone (ACSO), Status Report as of December 2015.
219. Izaña Atmospheric Research Center, Activity Report 2012-2014, 157 pp. June 2015.
220. Report of the Second Session of the CAS Environmental Pollution and Atmospheric Chemistry Scientific Steering Committee (EPAC SSC), Geneva, Switzerland, 18-20 February 2015, 54 pp. June 2015.
221. Report for the First Meeting of the WMO GAW Task Team on Observational Requirements and Satellite Measurements (TT-ObsReq) as regards Atmospheric Composition and Related Physical Parameters, Geneva, Switzerland, 10-13 November 2014, 22 pp. July 2015.
222. Analytical Methods for Atmospheric SF<sub>6</sub> Using GC- $\mu$ ECD, World Calibration Centre for SF<sub>6</sub> Technical Note No. 1. 47 pp. September 2015.
223. Eighth Intercomparison Campaign of the Regional Brewer Calibration Center for Europe (RBCC-E), El Arenosillo Atmospheric Sounding Station, Heulva, Spain, 10-20 June 2013, 79 pp. December 2015.
224. Ninth Intercomparison Campaign of the Regional Brewer Calibration Center for Europe (RBCC-E), Lichtklimatisches Observatorium, Arosa, Switzerland, 24-26 July 2014, 40 pp. December 2015.
225. WMO/UNEP Dobson Data Quality Workshop, Hradec Kralove, Czech Republic, 14-18 February 2011, 32 pp. April 2016.
226. Coupled Chemistry-Meteorology/Climate Modelling (CCMM): status and relevance for numerical weather prediction, atmospheric pollution and climate research, Geneva, Switzerland, 23-25 February 2015, (WMO-No. 1172, WCRP Report No. 9/2016), ISBN: 978-92-63-11172-2, 165 pp. May 2016.
227. WMO/GAW Aerosol Measurement Procedures, Guidelines and Recommendations, 2nd Edition 2016, (WMO-No. 1177, ISBN: 978-92-63-11177-7), 103 pp. 2016, (This report supersedes GAW Report No. 153).
228. WMO Global Atmosphere Watch (GAW) Strategic Plan: 2016-2023.

For more information, please contact:

**World Meteorological Organization**

**Research Department**

**Atmospheric Research and Environment Branch**

7 bis, avenue de la Paix – P.O. Box 2300 – CH 1211 Geneva 2 – Switzerland

Tel.: +41 (0) 22 730 81 11 – Fax: +41 (0) 22 730 81 81

E-mail: [GAW@wmo.int](mailto:GAW@wmo.int)

**Website: [http://www.wmo.int/pages/prog/arep/gaw/gaw\\_home\\_en.html](http://www.wmo.int/pages/prog/arep/gaw/gaw_home_en.html)**