



Climeworks' technology evolution

Empa, "Mining the Atmosphere"

Adelaide Calbry-Muzyka,
Senior Manager Sorbent Structures

June 26, 2024



Net zero requires carbon dioxide removal

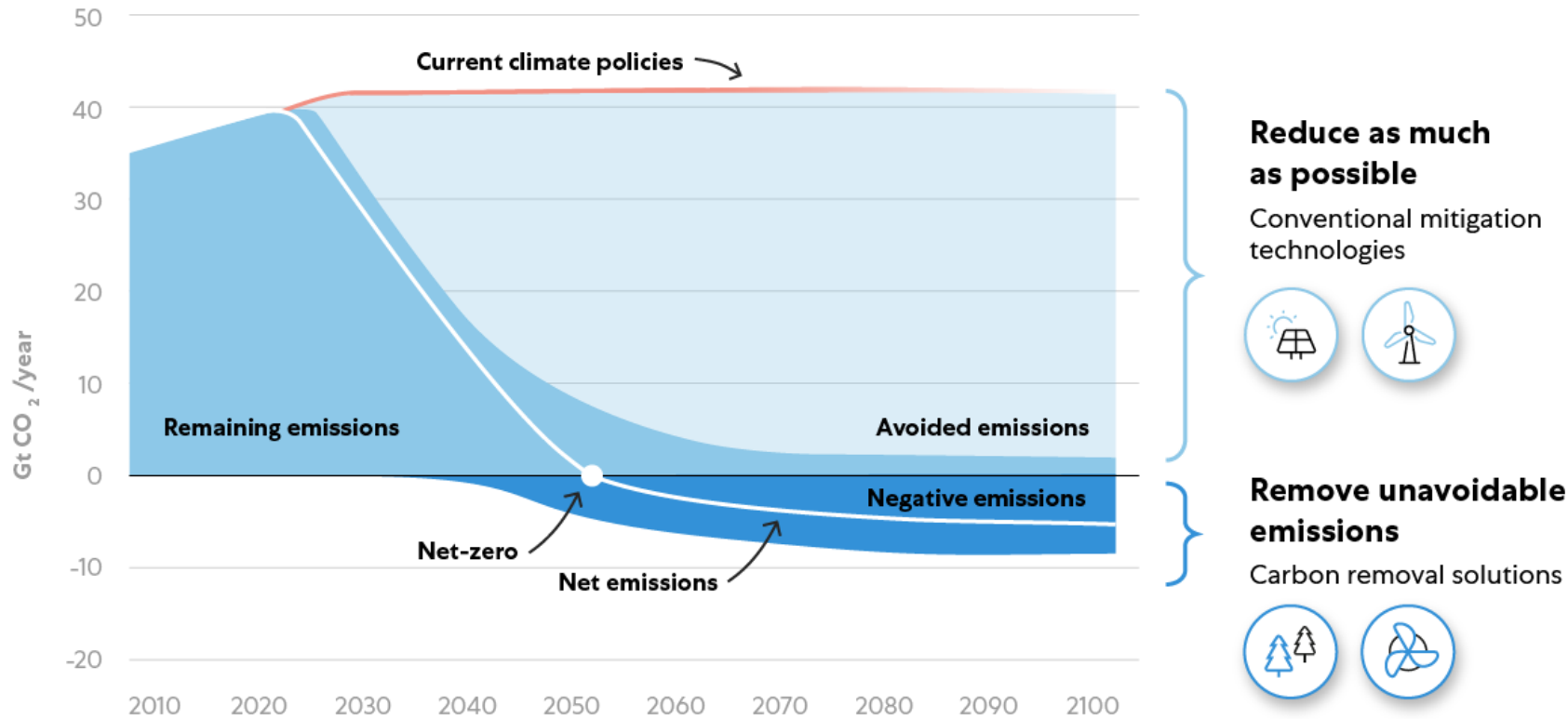

- Based on all IPCC scenarios, **CO₂ must be removed from the air** to keep global warming within 1.5°C.
- Companies need to accelerate emissions reduction while starting to invest in **removals for your residual emissions.**

Climeworks snapshot



Since 2009
>15 DAC facilities
Including the world's only commercial DAC+S facility Orca



400+
Climeworkers
dedicated to fighting
global warming



> 120,000
hours operational
experience



\$810m
raised



10X
scale-up steps already
delivered multiple
times

This is how our technology solution looks



Direct air capture and mineralization



Energy supply, direct air capture and storage (shown here: Climeworks' Orca)

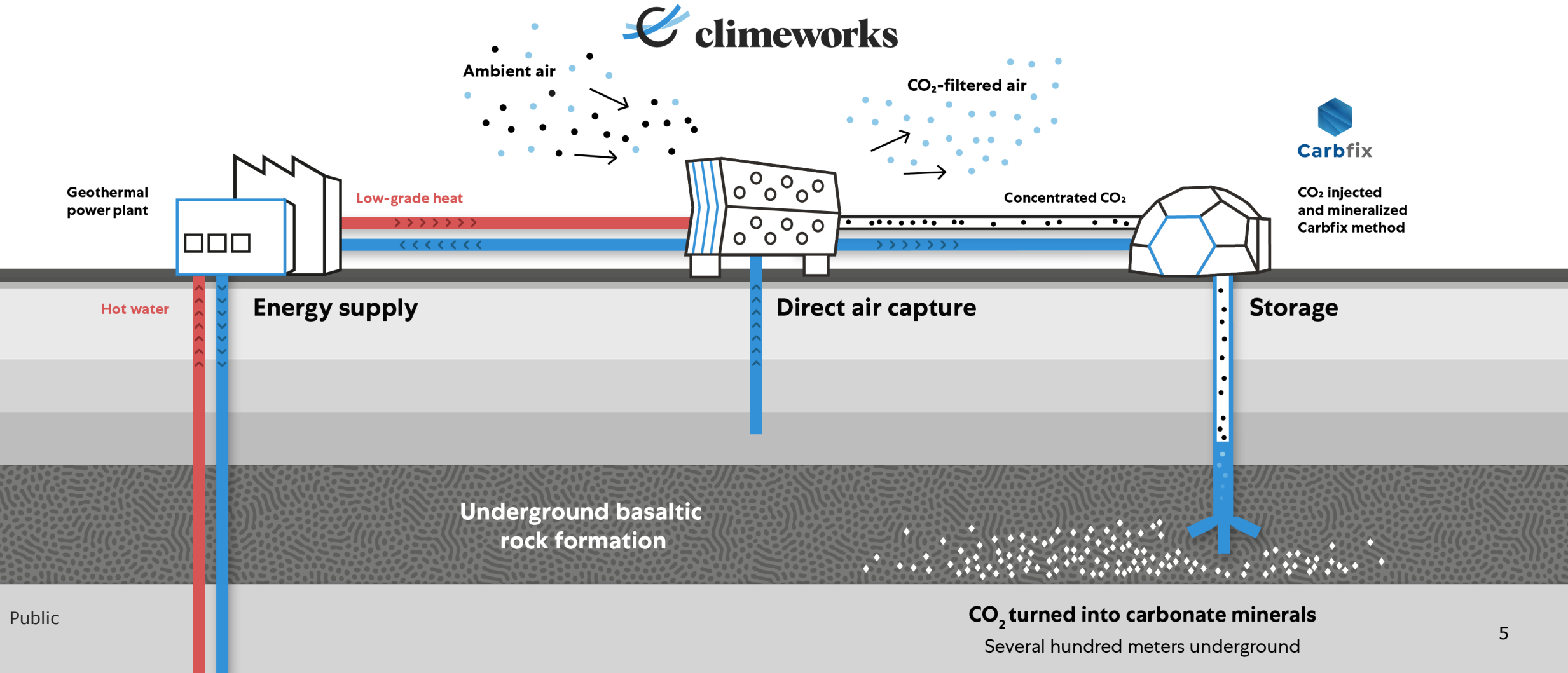

Our business model: CO₂ removal as a service



SWAROVSKI



verdane

stripe



amag



For companies

High-quality CO₂ removal as part of corporate emissions reduction roadmaps to achieve net zero and beyond.

For individuals

CO₂ removal as a service for individuals to remove emissions and enable DAC's scale-up:

www.climeworks.com/subscriptions

Climeworks projects worldwide

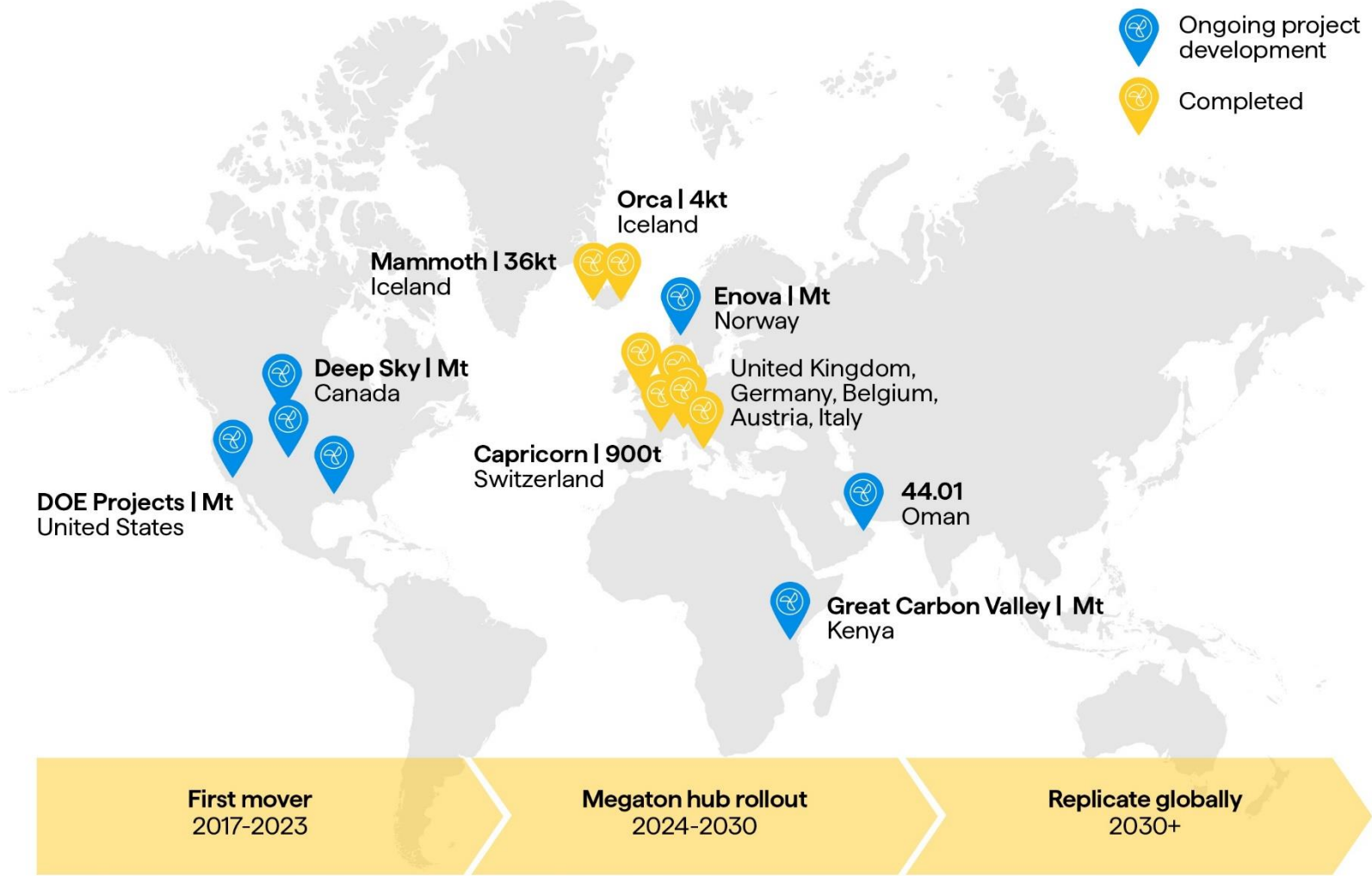

How our technology works

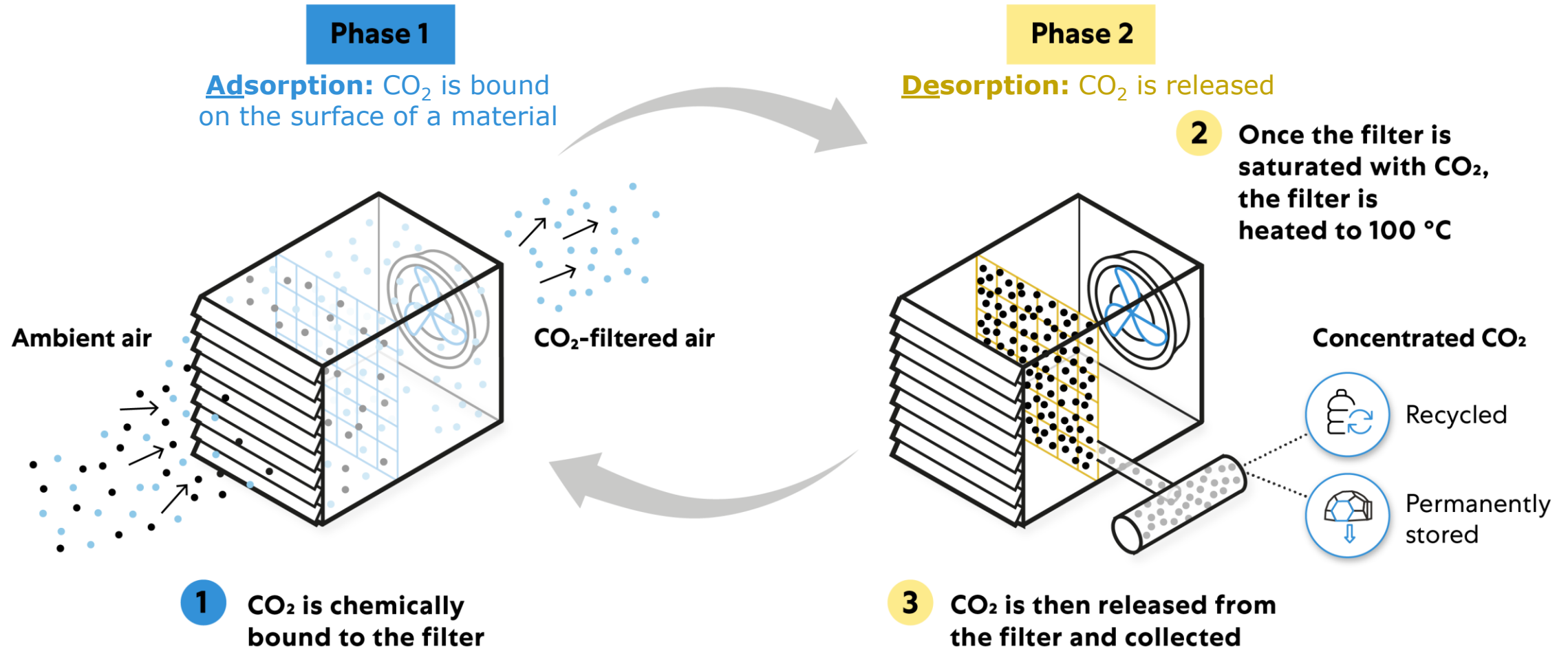

Looking inside: optimization problems



Adsorption

Challenge:

Load highly dilute 400 ppm CO₂ in air onto a sorbent quickly, efficiently, without prohibitive pressure drops

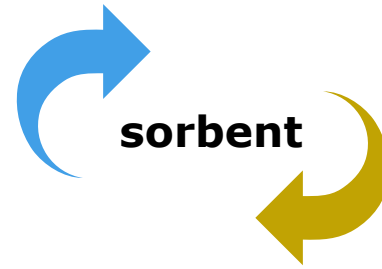

Desorption

Challenge:

Unload CO₂ as fully & as purely as possible, using a minimal amount of renewable electricity and heat

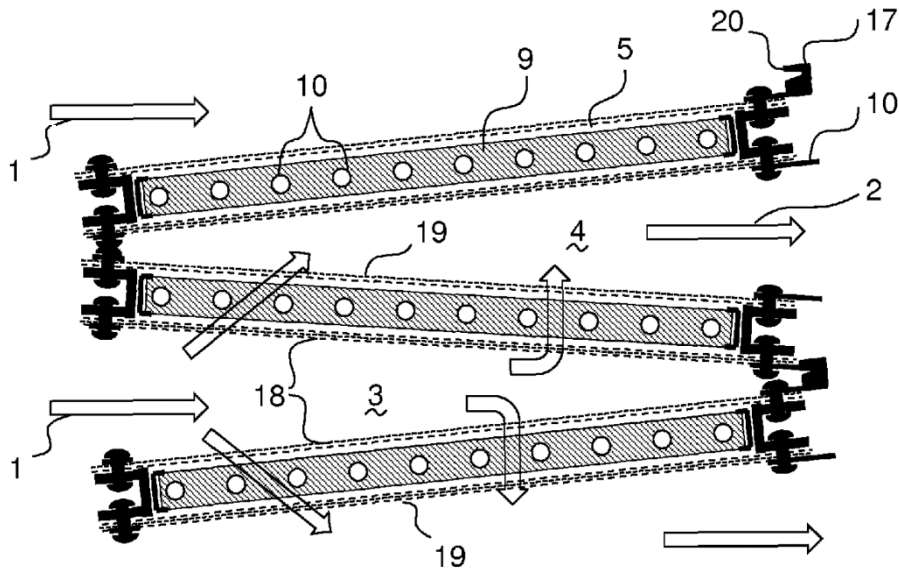

Temperature-
vacuum
swing
regeneration
process

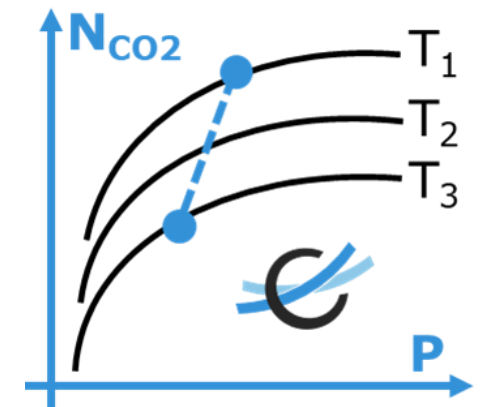

Our technology evolution



2014



2017



2021



2024



2024



Gen 1

Gen 2

Latest Gen 2 plant: Mammoth

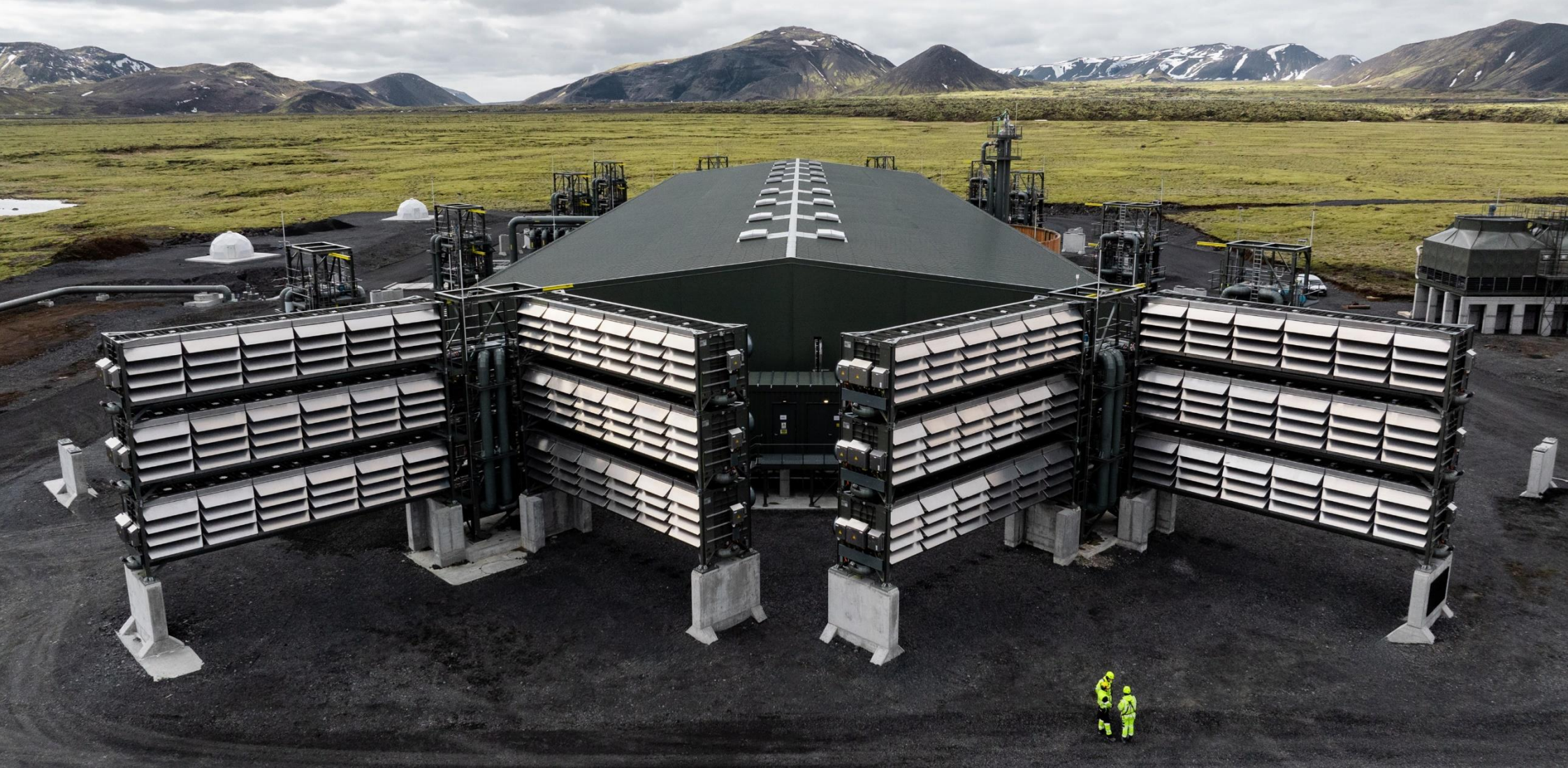





3

years of customer
delivery of CDR

120,000

hours of operational
DAC experience

7

years of field
experience

5th May 2024

Mammoth first CO₂ removed

200

million data points processed
daily by Climeworks engineers

Certified

under the Puro Standard -
a worldwide first



Our technology evolution



2014

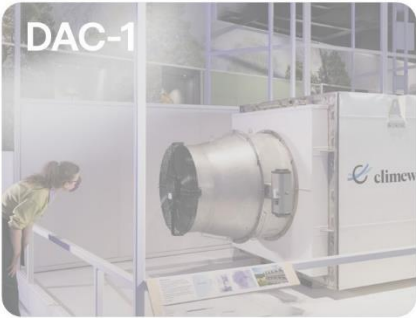

2017



2021



2024



2024



Gen 1

Gen 2

*2019
Gen 3



Generation 3

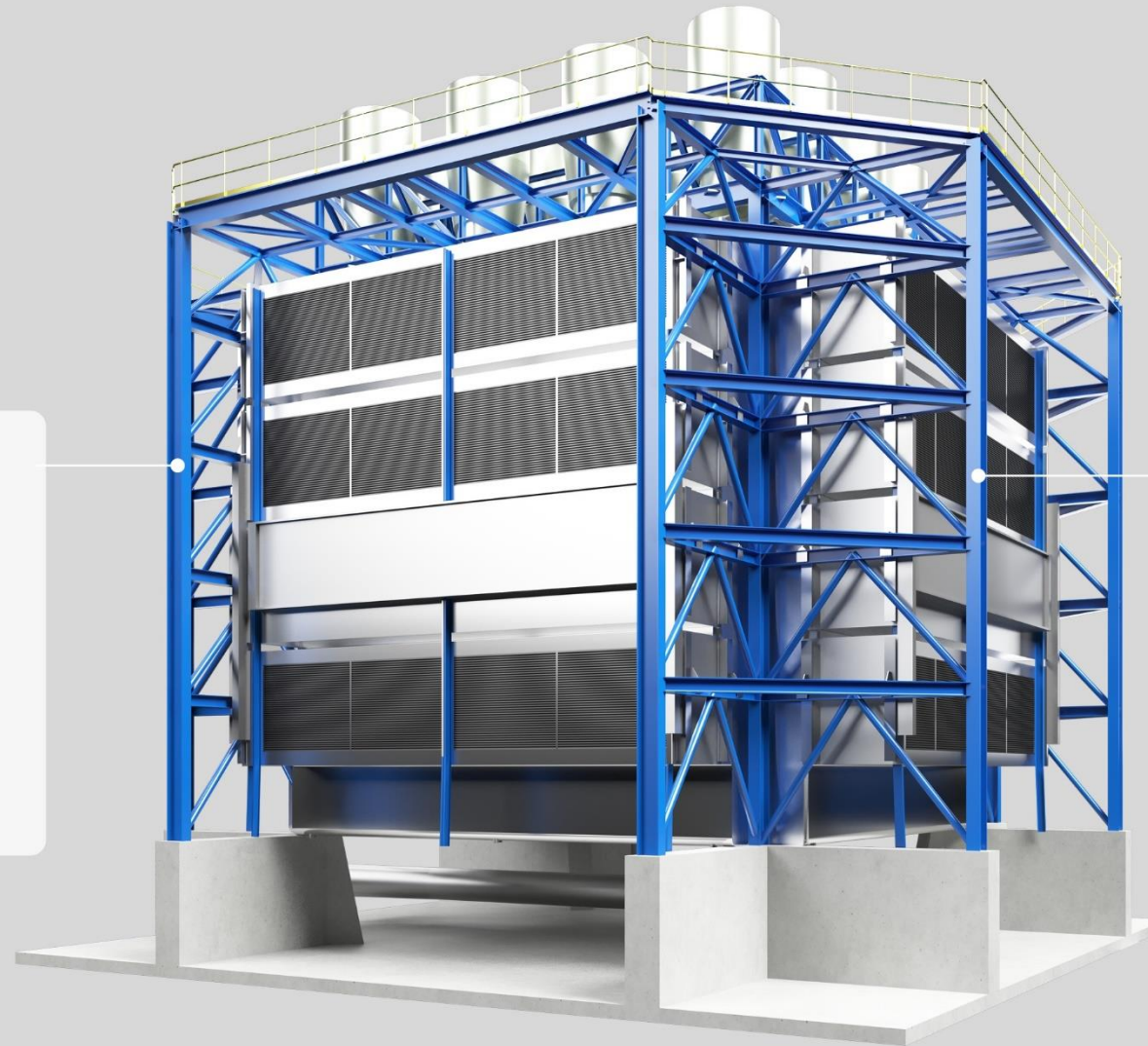

New system layout

- Improved energy utilization
- Increase robustness
- Reduced footprint

Different sorbents allowing for:

- Faster kinetics
- Higher throughput
- Faster desorption

R&D approach at Climeworks



Sorbent

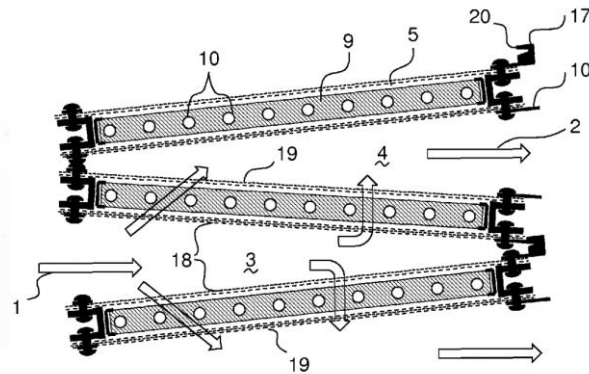

Sorbent Structure



**Collector/
Plant**

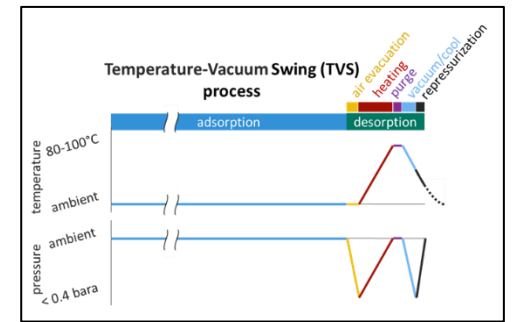

Process

R&D informed by field experience



Plant design

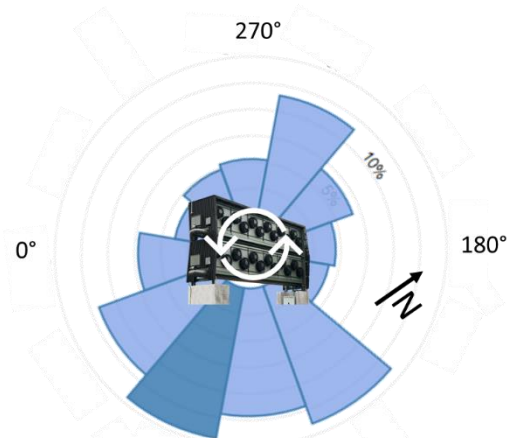

Air volume flow rate rel. to calm conditions
plant average

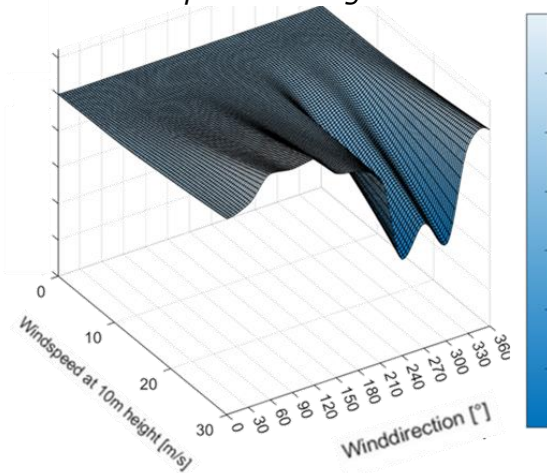

Materials of construction



Real World Conditions

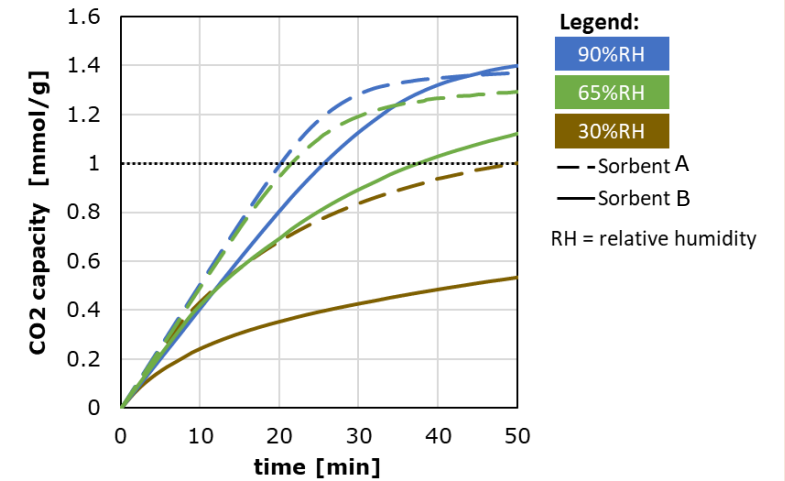

Gen 3 full-scale prototype: operational since May 2024

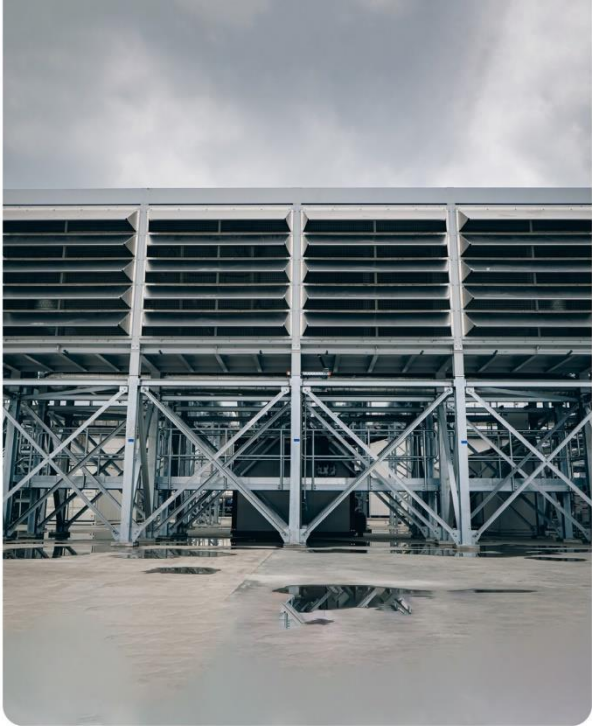

 Basel, Switzerland

Gen 3 in numbers



Achievements

↑ Increase
capture capacity

+100%
CO₂ capture

↑ Filter material
lifetime expectation

3x
material lifetime

↓ Reduce energy
consumption

-50%
energy

↓ Reduce
overall cost

-50%
cost

Climeworks plans continuous DAC capacity increase

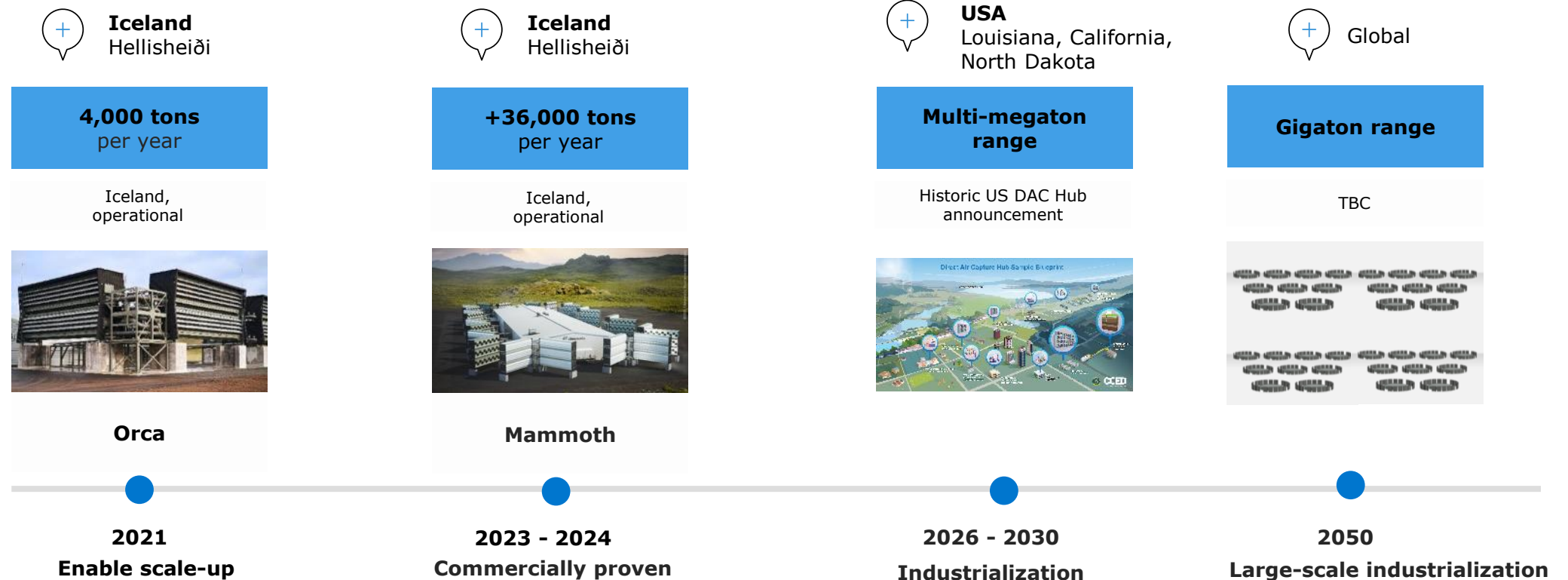

- Most advanced DAC player with real **field experience**
- World's **largest DAC+S facility** in commercial operations
- Over 120,000 hours of **operational experience** in diverse climatic conditions
- A clear strategy to **scale removal capacity** to megaton scale by 2030 and gigaton scale by 2050



Climeworks AG

Birchstrasse 155
8050 Zurich, Switzerland

+41 (0)44 533 29 99
contact@climeworks.com



www.climeworks.com



Over 9000 Gt of storage capacity potential

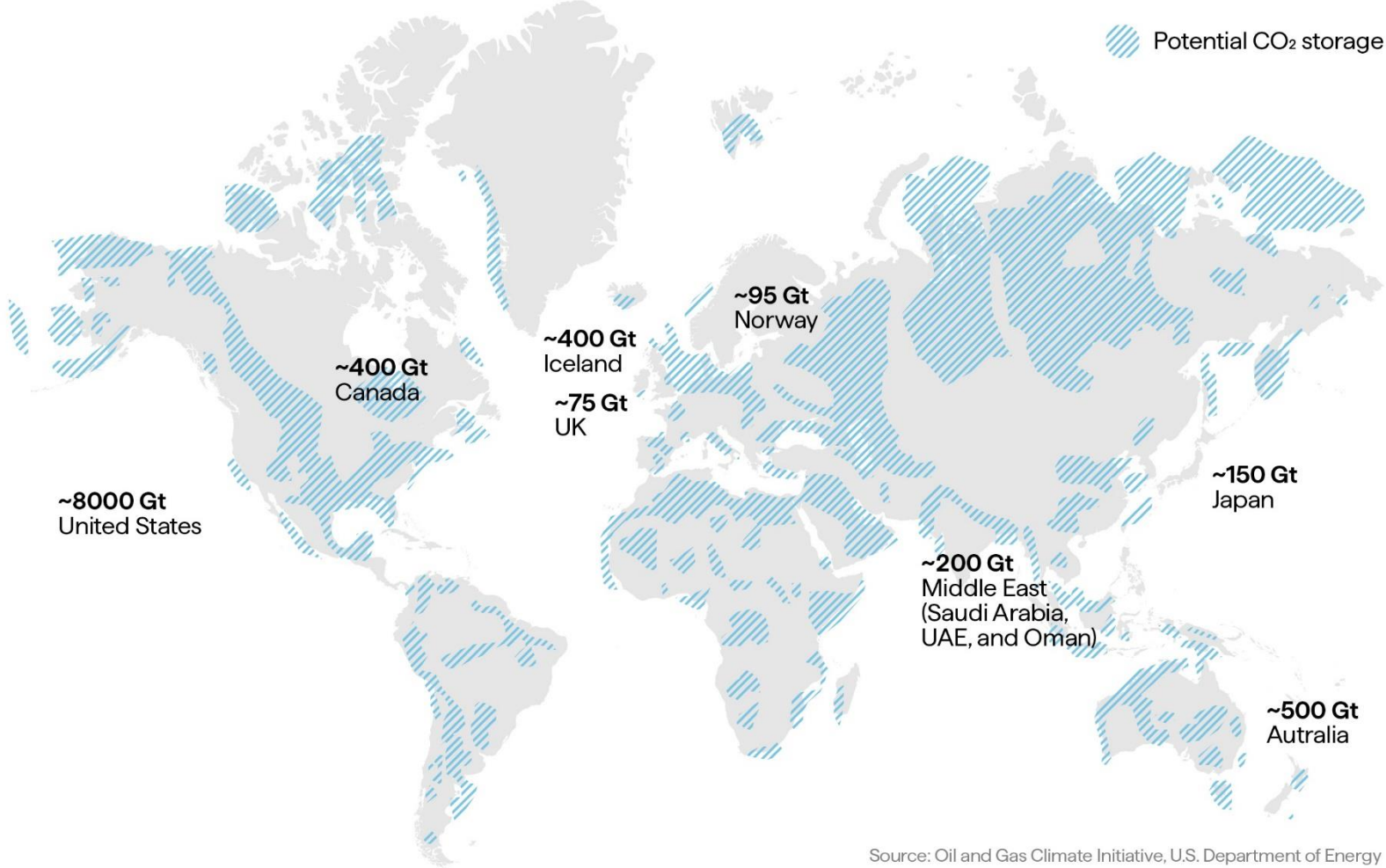

Source: Oil and Gas Climate Initiative, U.S. Department of Energy